

PRODUCT:

QUANTITY:

ITEM:

## Designed Smart

- The Bagel Master can generate up to 1440 toasted bagel halves per hour.
- Fastest bagel toaster in the industry...toasts in 15 seconds.
- Toaster has extended super feeder and warming area to allow for high volume production.
- Unique warming area keeps bagel at the perfect temperature until you are ready to serve.
- A variable speed control for the conveyor produces optimum results in toasting color.
- Able to handle a variety of bagels or muffins.
- Choose either a 2" or 3" product opening.
- Power Saver "stand-by" switch for short off-periods helps reduce energy by 30%.
- Cool Touch exteriors...both sides and top surfaces.
- Conveyors and crumb trays are easily accessible and simple to clean.
- Removable side panel allows easy access for service.
- High temperature bearings never require lubrication.



Model BT-15-2

## Options

- Cover for speed and temperature knobs.

## APW Wyott Design Features

- Individually controlled top and bottom heating elements.
- Superfeeder included.
- Removable reflector tray for ease in cleaning.
- Self-dispensing bread drawer slides forward for removal of product.
- Standby switch conserves energy during slow periods.
- Lighted rocker switch.
- Fully insulated and air-cooled.

## Reliability backed by APW Wyott's Warranty

All APW Wyott Heavy Toasters are backed by a 1-year parts and labor warranty, including on-site service calls within 50 miles of authorized service technicians.

•Certified by the following agencies:



See reverse side for product specifications.

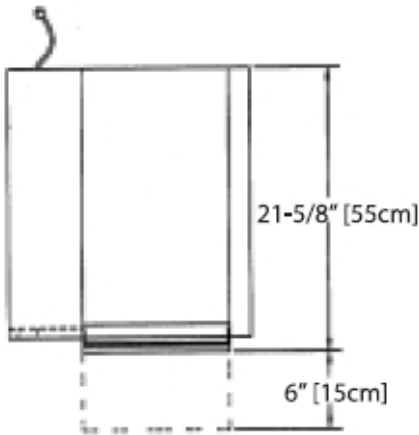

## PRODUCT SPECIFICATIONS:

### Construction:

Stainless steel housing and radiant reflector. Metal sheathed heating elements. Stainless steel wire conveyor and wire guard. High temperature insulation protects control panel and exteriors.

### Electrical Information:

Each unit is equipped with a 39", three wire grounded power cord which terminates with a standard three pronged male plug. The 208V/240V, use a NEMA 6-30P.

### Electrical Specifications;

BT-15-2:	208V, 4600W, 22.1Amps
	230V, 4600W, 19.8Amps
	240V, 4600W, 19.2Amps
BT-15-3:	208V, 4600W, 22.1Amps
	230V, 4600W, 19.8Amps
	240V, 4600W, 19.2Amps

### Capacity:

BT-15-2:	up to 1440 halves per hour
BT-15-3:	up to 1440 halves per hour

### Overall Dimensions:

BT-15-2:	18 1/2"H x 18 5/16"W x 26"D
FT-1000H:	19 1/2"H x 18 5/16"W x 26"D

### Shipping:

BT-15-2:	81 lbs.
BT-15-3:	86 lbs

### Freight Class: 100

FOB: Allen, TX 75013

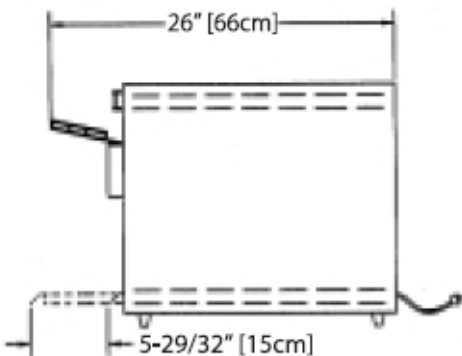
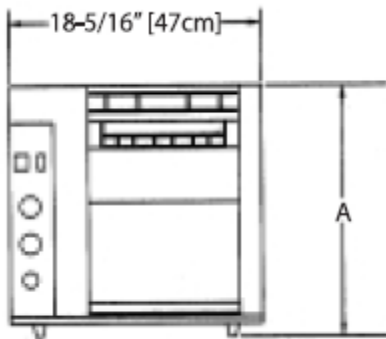

Toasters are constructed of stainless steel and aluminum material. Range of belt speeds should be 28 to 75 seconds. Front corners and front conveyor guard should be painted. Toasters furnished with 1" adjustable legs. Infrared metal sheathed radiant heaters are located on the top and bottom and are individually controlled by Infinite Heat Controls. On/Off switch has Indicator Light that glows when the toaster is on. Power saver switch will be supplied that reduces energy by 50%. Product opening is 1 1/2". Motors are permanently lubricated. Toaster will be Air Cooled with a thermostatically controlled fan that stays on until the toaster is cool to the touch. Control area has cooling fan. Units are UL listed, UL Sanitation, and Canadian UL approved.

\*APW Wyott reserves the right to modify specifications or discontinue models without incurring obligation.