

PRODUCT:

QUANTITY:

ITEM:

Models □ CW-1B

## Designed Smart

- Designed to cook and hold pre-cooked foods from frozen state.
- Perfect for soups, chili, and other dishes that need a quick thaw during the cooking cycles and a gentle warming heat for serving.
- CW-1B utilizes a bottom mounted heating element and an aluminum transfer plate to provide superior heat.
- CW-1B accepts an 11qt. Inset, or with adaptor a 7 or 4qt. Inset.
- Provided with knob guards
- Provided with insulation to protect interior parts and countertops from heat build-up.
- Preheats water to 212° in 10 minutes.



Model: CW-1B

## APW Wyott Design Features

- Wet usage 100°F to 212°F (38°C to 100°C) (recommended)
- Heavy-duty stainless steel for long life
- Easy to clean
- Thermostatically controlled
- Great for buffets, servings lines, back bars or back of the house
- Handles breakfast, lunch & dinner
- Pans and insets not included

## Built Solid Built to Last

- Constructed with heavy-duty stainless steel for long life
- Inside liner made with stainless steel
- Steel “element support” stabilizes heating elements and reflects heat toward food.

## Reliability Backed by APW Wyott's Warranty

All APW Wyott cooking equipment is backed by a 1-year limited warranty and a 1-year on-site labor warrant. \*

Certified by the following agencies:



See reverse side for product specifications.

PRODUCT:

QUANTITY:

ITEM:

## PRODUCT SPECIFICATIONS

### Construction:

Stainless steel housing and liner pan, 1" fiberglass insulation, 1" rubber legs.

### Electrical Information:

Unit is equipped with a 60", three wire grounded power cord which terminates with a standard three pronged male plug. The 120V unit uses a NEMA 5-15P plug. The 240V unit uses a NEMA 6-15P 90° plug.

### Electrical Specifications:

CW-1B	120V, 800W, 6.7Amps
	240V, 800W, 6.7Amps

### Capacity:

CW-1B	11 Quart
-------	----------

### Overall Dimensions:

CW-1B	10 5/8" H x 12 1/2" W x 12 1/2" D
	(27cm x 32cm x 32cm)

### Shipping:

CW-1B	16 lbs. (7.3 kg)
-------	------------------

**FOB:** Allen, TX 75013

**Class:** 100

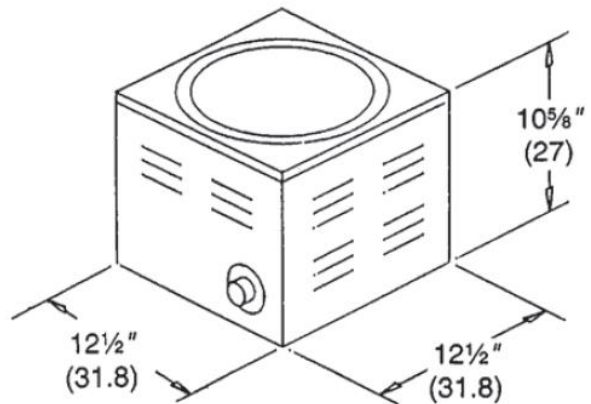

**Model CW-1B 11 Qt.  
Cooker/Warmer/Server**

\*APW Wyott reserves the right to modify specifications or discontinue models without incurring obligation.