



BDO-100-G-ES

MODEL BDO-100-G-ES Full-Size Convection Oven



Project _____

Item No. _____

Quantity _____

Standard depth baking compartment - accepts five 18" x 26" standard full-size baking pans in left-to-right positions.

All data is shown per oven section, unless otherwise indicated.

Refer to operator manual specification chart for listed model names.

EXTERIOR CONSTRUCTION

- Full angle-iron frame
- Stainless steel front, top, and sides
- Dual pane thermal glass windows encased in stainless steel door frames
- Tubular black soft touch handle with simultaneous door operation
- Triple-mounted pressure lock door design with turnbuckle assembly
- 1" solid block plus 1" mineral fiber insulation for a total of 2" of insulation

INTERIOR CONSTRUCTION

- Double-sided porcelainized baking compartment liner (16 gauge)
- Stainless steel combustion chamber
- Single inlet blower wheel
- Five chrome-plated racks, eleven rack positions with a minimum of 1-5/8" (41mm) spacing
- Interior lights

OPERATION

- Direct Fired Gas system
- Electronic spark ignition control system
- Removable inshot burners
- Internal pressure regulator
- Manual gas service cut-off switch located on the front of the control panel
- Solid state thermostat with temperature control range of 200°F (93°C) to 500°F (260°C)
- Two speed fan motor (single speed in CE model)
- 3/4 horsepower blower motor with automatic thermal overload protection
- Control area cooling fan

STANDARD FEATURES

- SSM - Solid state manual control with 60 minute electro-mechanical timer
- 25" (635mm) adjustable stainless steel legs (for single units)
- 6" (152mm) adjustable stainless steel legs (for double sections)
- Two year parts and one year labor warranty*

* For all international markets, contact your local distributor.

OPTIONS AND ACCESSORIES

(AT ADDITIONAL CHARGE)

■ Legs/casters/stands:

- 6" (152mm) seismic legs
- 6" (152mm) casters
- 4" (102mm) low profile casters (double only)
- 25" (635mm) stainless steel stand w/rack guides
- 29" (737mm) stainless steel, fully welded open stand with pan supports

■ Gas hose w/quick disconnect restraining device:

- 48" (1219mm) hose
- 36" (914mm) hose
- Extra oven racks
- Gas manifold (for double sections)
- Flue connector
- Draft hood for venting

OPTIONS AND ACCESSORIES

(AT NO CHARGE)

- Solid stainless steel doors



BLODGETT OVEN COMPANY

www.blodgett.com • 44 Lakeside Avenue, Burlington, VT 05401 • Phone: (802) 658-6600 • Fax: (802) 864-0183



BDO-100-G-ES

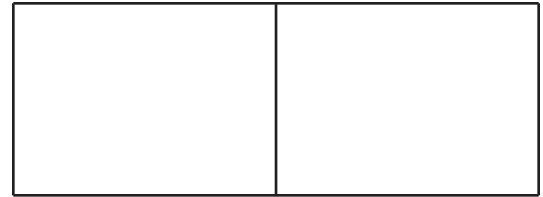

APPROVAL/STAMP

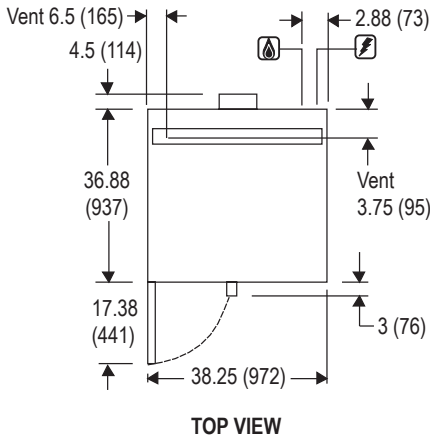

DIMENSIONS ARE IN INCHES (MM)

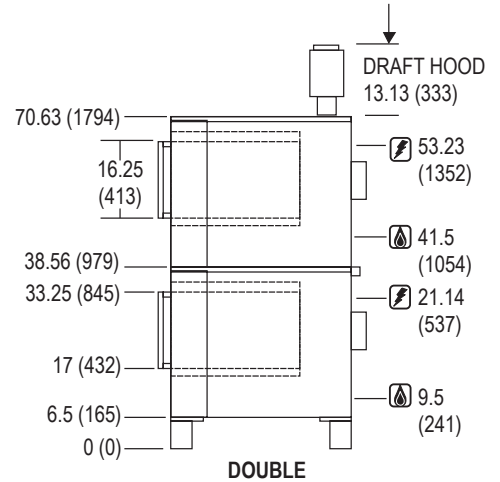
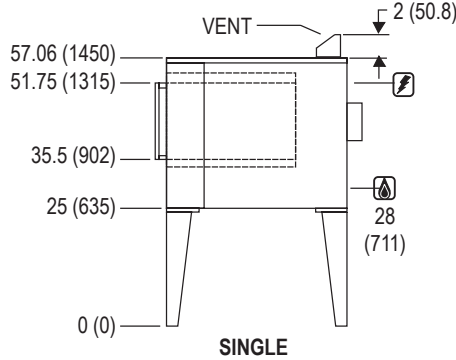

SHORT FORM SPECIFICATIONS: Provide Blodgett full-size convection oven model BDO-100-G-ES, (single/double) compartment. Each compartment shall have (porcelainized/stainless) steel liner and shall accept five 18" x 26" standard full-size bake pans. Stainless steel front, top and sides. Doors shall be (solid stainless steel/dual pane thermal glass windows) with single tubular black soft touch handle and simultaneous operation. Unit shall be gas heated with electronic spark ignition and shall cook by means of a direct fired system with a gas shutoff switch on the front of the control panel. Air in baking chamber distributed by single inlet blower wheel powered by a two-speed (single speed for CE model), 3/4 HP motor with thermal overload protection. Each chamber shall be fitted with two lamps and five chrome-plated removable racks. Control panel shall be recessed with Cook/Cool Down mode selector, solid state (manual) infinite thermostat (200- 500°F), and 60-minute timer. Provide two year parts, one year labor warranty. Provide options and accessories as indicated.

DIMENSIONS:

Floor space 38-1/4" (972mm) W x 36-7/8" (937mm) D
 Product clearance 0" from combustible and non-combustible construction
 Interior 29" (737mm) W x 20" (508mm) H x 24-1/4" (616mm) D

If oven is on casters:

Single Add 4-1/2" (114mm) to all height dimensions
 Double Height dimensions remain the same
 Double Low Profile Subtract 2.5" (64mm) from all height dimensions

GAS SUPPLY:

3/4" NPT

Manifold Pressure:

Natural 3.5" W.C.
 Propane 10" W.C.

Inlet Pressure:

Natural 7.0" W.C. min. – 10.5" W.C. max.
 Propane 11.0" W.C. min. – 13.0" W.C. max.

MAXIMUM INPUT:

Single 45,000 BTU/hr (13.2 Kw)
 Double 90,000 BTU/hr (26.4 Kw)

POWER SUPPLY:

115 VAC, 1 phase, 8 Amp, 60 Hz., 2-wire with ground,
 3/4 H.P., 2 speed motor, 1120 and 1680 RPM
 6' (1.8m) electric cord set furnished on 115 VAC ovens only.
 Blodgett recommends a Pass & Seymour, model 2097, GFCI due to the use of a variable frequency drive. Must be hard wired in some cases.

MINIMUM ENTRY CLEARANCE:

Uncrated 32-1/16" (814mm)
 Crated 37-1/2" (953mm)

SHIPPING INFORMATION:

Approx. Weight:

Single 590 lbs. (268 kg)
 Double 1095 lbs. (497 kg)

Crate sizes:

37-1/2" (952mm) x 43-1/2" (1105mm) x 51-3/4" (1315mm)

NOTE: The company reserves the right to make substitutions of components without prior notice

BLODGETT OVEN COMPANY

www.blodgett.com • 44 Lakeside Avenue, Burlington, VT 05401 • Phone: (802) 658-6600 • Fax: (802) 864-0183