

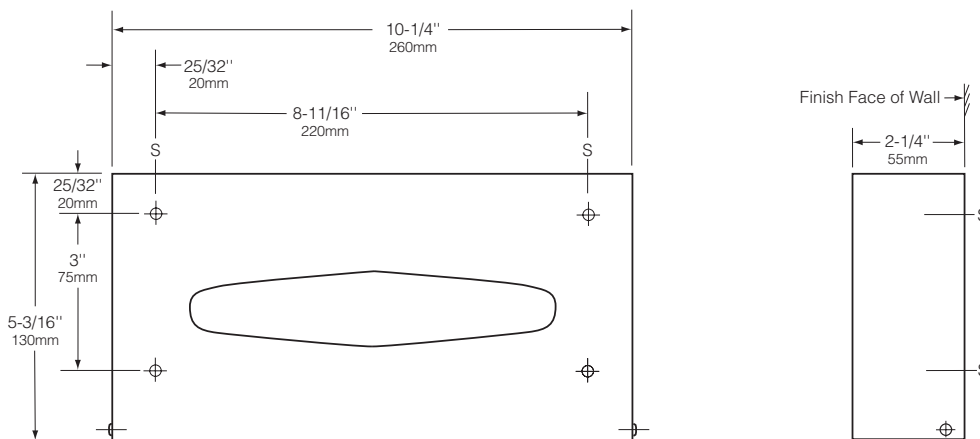

Technical Data

# SURFACE-MOUNTED FACIAL TISSUE DISPENSER

# B-8397

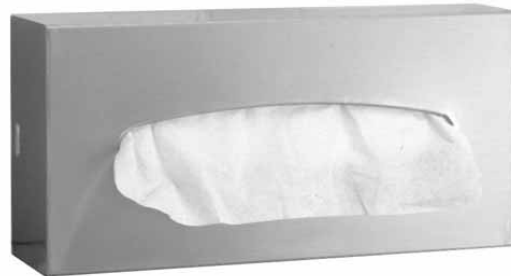

## MATERIALS:

**Cabinet** — 18-8 S, type-304, 24-gauge (0.6mm) stainless steel. All-welded construction. Exposed surfaces have satin finish. Equipped with a concealed locking device; opens with special key provided. Secured to concealed wall plate with pivot hinges. Capacity: one box of 100 two-ply facial tissues.

**Wall Plate** — 18-8 S, type-304, 22-gauge (0.8mm) stainless steel.

## OPERATION:

Cabinet unlocks with special key provided, then swings down to replace box of 100 two-ply facial tissues.

## INSTALLATION:

Mount unit on wall or countertop apron with four #8 x 1-1/4" (4.2 x 32mm) sheet-metal screws (not furnished) at points indicated by an S. For plaster or dry wall construction, provide concealed backing to comply with local building codes, then secure unit with sheet-metal screws. For other wall surfaces, provide fiber plugs or expansion shields for use with sheet-metal screws, or provide 1/8" (3mm) toggle bolts or expansion bolts.

**Note:** Provide a 2-1/4" (55mm) minimum clearance above unit to provide access to lock and 2-1/4" (55mm) clearance below unit to allow tissue dispenser to swing down for refilling.

## SPECIFICATION:

Surface-mounted facial tissue dispenser shall be type-304 stainless steel with all-welded construction; exposed surfaces shall have satin finish. Cabinet shall be secured to a concealed wall plate with pivot hinges and equipped with a concealed locking device that is opened only with special key provided. Unit shall hold one box of 100 two-ply facial tissues. Manufacturer's service and parts manual shall be provided to the building owner/manager upon completion of project.

**Surface-Mounted Facial Tissue Dispenser shall be Model B-8397 of Bobrick Washroom Equipment, Inc., Clifton Park, New York; Jackson, Tennessee; Los Angeles, California; Bobrick Washroom Equipment Company, Scarborough, Ontario; Bobrick Washroom Equipment Pty. Ltd., Australia; and Bobrick Washroom Equipment Limited, United Kingdom.**