



Project _____
 Item # _____
 Quantity _____

Glo-Ray® Aluminum Dual Infrared Strip Heaters

Models:

- GRA-18D, -24D, -30D, -36D, -42D, -48D, -54D, -60D, -66D, -72D, -84D, -96D, -108D, -120D, -132D, -144D
 GRAH-18D, -24D, -30D, -36D, -42D, -48D, -54D, -60D, -66D, -72D, -84D, -96D, -108D, -120D, -132D, -144D

Create a deeper holding area with Glo-Ray® Aluminum Dual Infrared Foodwarmers with two heaters mounted side-by-side, keeping hot food at optimum serving temperatures. The pre-focused heat pattern directs heat from a metal sheathed element across the entire holding surface. The continuous aluminum housing and heavy-duty mountings ensure the durability and quality of Hatco products.

Standard features

- Provides even heat distribution – no “cold spots”
- Pre-focused heat maintains safe serving temperatures longer
- Sturdy extruded aluminum housings that do not sag, from 18" to 144" (457 to 3658 mm)
- Reflector does not blacken, maintaining a consistent heat pattern
- Reinforced wire guards provide operator safety without affecting heat distribution
- 3" or 6" (76 or 152 mm) spacer available as a center section between two 6" (152 mm) heater sections for a deeper holding area
- Heavy-duty insulation minimizes heat loss
- Optional sneeze guard made of shatterproof, easy-to-clean acrylic provide safe food serving environment
- Additional reflector styles and lower wattage elements also available, please consult factory for more information
- Metal sheathed heating elements guaranteed against burnout and breakage for two years

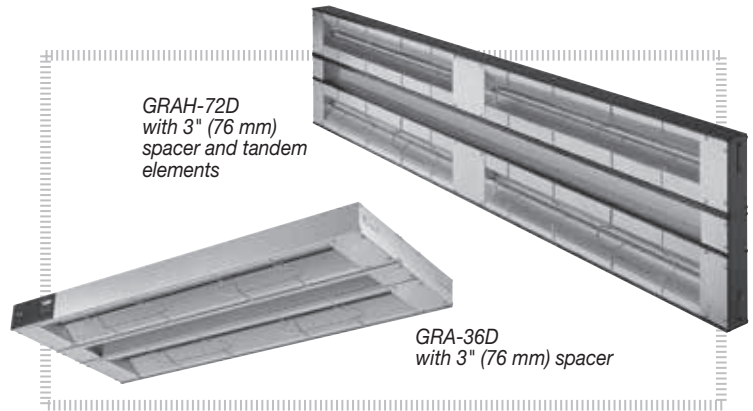

Options (available at time of purchase only)

- Housing – Clear Anodized finish Standard
 15" (4572 mm) 18" (457 mm)
Designer Color or Gloss Finish – Non-standard colors are non-returnable
 Warm Red Black Gray Granite White Granite
 Navy Blue Hunter Green Antique Copper
 Radiant Red Glossy Gray Bold Black Gleaming Gold
 Brilliant Blue
- Indicator Light (Remote only)
- Leads – Extended Beyond Standard 3' (914 mm) Conduit
 Please specify lead length
 1'-5" (305-1525 mm) 6'-10" (1829-3048 mm)
 11'-15" (3352-4572 mm) 16'-20" (4877-6096 mm)
- Sneeze Guard
 9.375" (238 mm) – One Side 9.375" (238 mm) – Two Sides
 14" (356 mm) – One Side 14" (356 mm) – Two Sides
- Remote Infinite Switches in lieu of Toggle (max. 12.2 amps)
 Remote Toggle Switches (max. 15 amps)
- Remote Box – Clear Anodized finish Standard
Designer Color or Gloss Finish – Non-standard colors are non-returnable
 Warm Red Black Gray Granite White Granite
 Navy Blue Hunter Green Antique Copper
 Radiant Red Glossy Gray Bold Black Gleaming Gold
 Brilliant Blue
- Factory attaches Control Box to Strip Heater (Export only)
- Adjustable Tubular Stands 10"-14" (254-356 mm)
 (not available in *Designer* colors)
- Non-Adjustable Tubular Stands – Aluminum finish Standard
 Choose clearance below
 10" (254 mm) 12" (305 mm) 14" (356 mm) 16" (406 mm)
Designer Color or Gloss Finish – Non-standard colors are non-returnable
 Warm Red Black Gray Granite White Granite
 Navy Blue Hunter Green Antique Copper
 Radiant Red Glossy Gray Bold Black Gleaming Gold
 Brilliant Blue
- ## Accessories
- Adjustable Angle Brackets (with clearance above unit)
 1"-2" (25-51 mm) 7" (178 mm) - GRA-xxD models only
- Chain Suspension



HATCO CORPORATION | P.O. Box 340500 Milwaukee, WI 53234-0500 U.S.A.

(800) 558-0607 | (414) 671-6350 | www.hatcocorp.com | equipmentsales@hatcocorp.com | intl@hatcocorp.com



Glo-Ray® Aluminum Dual Infrared Strip Heaters

Models: GRA-18D, -24D, -30D, -36D, -42D, -48D, -54D, -60D, -66D, -72D, -84D, -96D, -108D, -120D, -132D, -144D
 GRAH-18D, -24D, -30D, -36D, -42D, -48D, -54D, -60D, -66D, -72D, -84D, -96D, -108D, -120D, -132D, -144D

GRA-D and GRAH-D

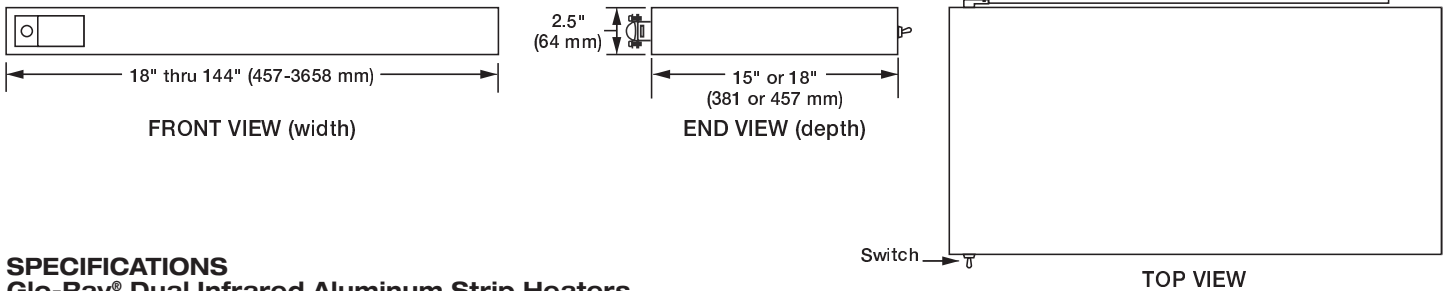

SPECIFICATIONS

Glo-Ray® Dual Infrared Aluminum Strip Heaters

Dimensions: with 3" (76 mm) Spacer: 18" - 144 W x 15" D x 2.5" H (457 - 3658 mm x 381 mm x 64 mm)
 with 6" (152 mm) Spacer: 18" - 144 W x 18" D x 2.5" H (457 - 3658 mm x 457 mm x 64 mm)

Phase: All Single Phase

Amps: Amps on all models can vary based on configuration – please consult factory.

The shaded areas contain electrical information for international models

Standard Watt			High Watt			Both Models	
Model	Volts	Watt	Model	Volts	Watt	Width	Ship Weight.*
GRA-18D	120	500	GRAH-18D	120	700	18" (457 mm)	14 lbs. (7 kg.)
	208						
	240						
	-	-		100	700		
	200	462		200	647		
	220	500		220	700		
	220-230 (CE)*	500-546		220-230 (CE)*	700-765		
230-240 (CE)*	459-500	230-240 (CE)*	643-700				
240	500	240	700				
GRA-24D	120	700	GRAH-24D	120	1000	24" (610 mm)	16 lbs. (8 kg.)
	208						
	240						
	-	-		100	1000		
	200	647		200	925		
	220	700		220	1000		
	220-230 (CE)*	700-765		220-230 (CE)*	1000-1093		
230-240 (CE)*	643-700	230-240 (CE)*	918-1000				
240	700	240	1000				
GRA-30D	120	900	GRAH-30D [■]	120	1320	30" (762 mm)	18 lbs. (9 kg.)
	208						
	240						
	-	-		100	1320		
	200	832		200	1220		
	220	900		220	1320		
	220-230 (CE)*	900-984		220-230 (CE)*	1320-1443		
230-240 (CE)*	827-900	230-240 (CE)*	1212-1320				
240	900	240	1320				
GRA-36D	120	1150	GRAH-36D [■]	120	1600	36" (914 mm)	19 lbs. (9 kg.)
	208						
	240						
	-	-		100	1600		
	200	1063		200	1479		
	220	1150		220	1600		
	220-230 (CE)*	1150-1257		220-230 (CE)*	1600-1749		
230-240 (CE)*	1056-1150	230-240 (CE)*	1469-1600				
240	1150	240	1600				
GRA-42D [■]	120	1350	GRAH-42D [■]	120	1900	42" (1067 mm)	23 lbs. (11 kg.)
	208						
	240						
	-	-		100	1900		
	200	1248		200	1757		
	220	1350		220	1900		
	220-230 (CE)*	1350-1476		220-230 (CE)*	1900-2077		
230-240 (CE)*	1240-1350	230-240 (CE)*	1745-1900				
240	1350	240	1900				

* Shipping weight includes packaging, and does not include RMB.

* CE approved units for 220-230V utilize a 220V heating system; 230-240V CE units utilize a 240V heating system.

■ 100V and 120V models may require additional switches, consult factory for applications.

HATCO CORPORATION | P.O. Box 340500 Milwaukee, WI 53234-0500 U.S.A.

(800) 558-0607 | (414) 671-6350 | www.hatcocorp.com | equipsales@hatcocorp.com | intlSales@hatcocorp.com



Glo-Ray® Aluminum Dual Infrared Strip Heaters

Models: GRA -18D, -24D, -30D, -36D, -42D, -48D, -54D, -60D, -66D, -72D, -84D, -96D, -108D, -120D, -132D, -144D
 GRAH -18D, -24D, -30D, -36D, -42D, -48D, -54D, -60D, -66D, -72D, -84D, -96D, -108D, -120D, -132D, -144D

Glo-Ray® Dual Infrared Aluminum Strip Heaters

Dimensions: with 3" (76 mm) Spacer: 18" - 144 W x 15" D x 2.5" H (457 - 3658 mm x 381 mm x 64 mm)
 with 6" (152 mm) Spacer: 18" - 144 W x 18" D x 2.5" H (457 - 3658 mm x 457 mm x 64 mm)

Amps: Amps on all models can vary based on configuration – please consult factory.

The shaded areas contain electrical information for International models

Standard Watt			High Watt			Both Models	
Model	Volts	Watt	Model	Volts	Watt	Width	Ship Weight*
GRA-48D [■]	120	1600	GRAH-48D [■]	120	2200	48" (1219 mm)	27 lbs. (12 kg.)
	208			208			
	240			240			
	-	-		100	2200		
	200	1479		200	2034		
	220	1600		220	2200		
	220-230 (CE)*	1600-1749		220-230 (CE)*	2200-2405		
	230-240 (CE)*	1469-1600		230-240 (CE)*	1745-2200		
240	1600	240	2200				
GRA-54D [■]	120	1850	GRAH-54D [■]	120	2500	54" (1372 mm)	30 lbs. (14 kg.)
	208			208			
	240			240			
	-	-		100	2500		
	200	1710		200	2311		
	220	1850		220	2500		
	220-230 (CE)*	1850-2022		220-230 (CE)*	2500-2732		
	230-240 (CE)*	1699-1850		230-240 (CE)*	2296-2500		
240	1850	240	2500				
GRA-60D [■]	120	2100	GRAH-60D [■]	120	2800	60" (1524 mm)	35 lbs. (16 kg.)
	208			208			
	240			240			
	-	-		100	2800		
	200	1942		200	2589		
	220	2100		220	2800		
	220-230 (CE)*	2100-2295		220-230 (CE)*	2800-3060		
	230-240 (CE)*	1929-2100		230-240 (CE)*	2572-2800		
240	2100	240	2800				
GRA-66D [■]	120	2320	GRAH-66D [■]	120	3120	66" (1676 mm)	36 lbs. (17 kg.)
	208			208			
	240			240			
	-	-		100	3120		
	200	2145		200	2885		
	220	2320		220	3120		
	220-230 (CE)*	2320-2536		220-230 (CE)*	3120-3410		
	230-240 (CE)*	2131-2320		230-240 (CE)*	2865-3120		
240	2320	240	3120				
GRA-72D [■]	120	2550	GRAH-72D [■]	120	3450	72" (1829 mm)	40 lbs. (19 kg.)
	208			208			
	240			240			
	-	-		100	3450		
	200	2358		200	3190		
	220	2550		220	3450		
	220-230 (CE)*	2550-2787		220-230 (CE)*	3450-3771		
	230-240 (CE)*	2342-2550		230-240 (CE)*	3169-3450		
240	2550	240	3450				
GRA-84D [▼]	120	3000	GRAH-84D [†]	120	4100	84" (2134 mm)	50 lbs. (23 kg.)
	208			208			
	240			240			
	-	-		100	4100		
	200	2774		200	3791		
	220	3000		220	4100		
	220-230 (CE)*	3000-3279		220-230 (CE)*	4100-4481		
	230-240 (CE)*	2755-3000		230-240 (CE)*	3765-4100		
240	3000	240	4100				
GRA-96D [▼]	120	3450	GRAH-96D [†]	120	4800	96" (2438 mm)	52 lbs. (24 kg.)
	208			208			
	240			240			
	-	-		100	4800		
	200	3190		200	4438		
	220	3450		220	4800		
	220-230 (CE)*	3450-3771		220-230 (CE)*	4800-5246		
	230-240 (CE)*	3169-3450		230-240 (CE)*	4408-4800		
240	3450	240	4800				

* Shipping weight includes packaging, and does not include RMB.
[■] 100V and 120V models may require additional switches, consult factory for applications.
[♦] CE approved units for 220-230V utilize a 220V heating system; 230-240V CE units utilize a 240V heating system.
[▼] 100V and 120V models with infinite switch require tandem (end-to-end) elements, consult factory for applications.
[†] Contain tandem (end-to-end) elements that may be individually controlled.

HATCO CORPORATION | P.O. Box 340500 Milwaukee, WI 53234-0500 U.S.A.

(800) 558-0607 | (414) 671-6350 | www.hatcocorp.com | equipsales@hatcocorp.com | intl@hatcocorp.com



Glo-Ray® Aluminum Dual Infrared Strip Heaters

Models: GRA -18D, -24D, -30D, -36D, -42D, -48D, -54D, -60D, -66D, -72D, -84D, -96D, -108D, -120D, -132D, -144D
 GRAH -18D, -24D, -30D, -36D, -42D, -48D, -54D, -60D, -66D, -72D, -84D, -96D, -108D, -120D, -132D, -144D

Glo-Ray® Dual Infrared Aluminum Strip Heaters

Dimensions: with 3" (76 mm) Spacer: 18" - 144 W x 15" D x 2.5" H (457 - 3658 mm x 381 mm x 64 mm)
 with 6" (152 mm) Spacer: 18" - 144 W x 18" D x 2.5" H (457 - 3658 mm x 457 mm x 64 mm)

Amps: Amps on all models can vary based on configuration – please consult factory.

The shaded areas contain electrical information for International models

Standard Watt			High Watt			Both Models	
Model	Volts	Watt	Model	Volts	Watt	Width	Ship Weight*
GRA-108D †	120	3700	GRAH-108D †	120	5000	108" (2743 mm)	59 lbs. (27 kg.)
	208						
	240						
	220	3700		220	5000		
	220-230 (CE)*	3700-4044		220-230 (CE)*	5000-5465		
	230-240 (CE)*	3398-3700		230-240 (CE)*	4592-5000		
240	3700	240	5000				
GRA-120D †	120	4200	GRAH-120D †	120	5600	120" (3048 mm)	66 lbs. (30 kg.)
	208						
	240						
	220	4200		220	5600		
	220-230 (CE)*	4200-4591		220-230 (CE)*	5600-6121		
	230-240 (CE)*	3857-4200		230-240 (CE)*	5143-5600		
240	4200	240	5600				
GRA-132D †	120	4640	GRAH-132D †	-	6240	132" (3353 mm)	73 lbs. (34 kg.)
	208						
	240						
	220	4640		220	6240		
	220-230 (CE)*	4640-5071		220-230 (CE)*	6240-6820		
	230-240 (CE)*	4261-4640		230-240 (CE)*	5731-6240		
240	4640	240	6240				
GRA-144D †	120	5100	GRAH-144D †	-	6900	144" (3658 mm)	80 lbs. (37 kg.)
	208						
	240						
	220	5100		220	6900		
	220-230 (CE)*	5100-5574		220-230 (CE)*	6900-7542		
	230-240 (CE)*	4684-5100		230-240 (CE)*	6337-6900		
240	5100	240	6900				

* Shipping weight includes packaging, and does not include RMB.

† 100V and 120V models may require additional switches, consult factory for applications.

‡ Glo-Ray models 108"-144" (2743-3658 mm) and 120 volt models of GRAH-84 and GRAH-96 contain tandem (end-to-end) elements that may be individually controlled.

• CE approved units for 220-230V utilize a 220V heating system; 230-240V CE units utilize a 240V heating system.

TOGGLE SWITCH: Amps: Max. 15 amps. Location: Chef's left side.

INFINITE SWITCH: Max. 12.2 amps Location: remote installation only

CONDUIT: 3' (914 mm) conduit standard on 120V and 208V models only

LEADS: US/Canada: 6" (152 mm) leads, server's right side
 Euro/UK GRAH-xxD: 6" (152 mm) pigtail leads with no conduit, servers right side

RECOMMENDED MOUNTING HEIGHTS

(Refer to the Installation section of the Manual on the Hatco website)

Units with 3" (76 mm) and 6" (152 mm) Spacers

Standard Watt: 10"-14" (254-356 mm)

High Watt: 14"-18" (356-457 mm)

MINIMUM CLEARANCES

Combustibles

Cannot be installed in combustible surroundings

Non-Combustibles

Dual Units with Built-In Switches

Unit to surface below: 10" (254 mm)

Must be installed in pass through area, back wall installation not allowed

Below overshelf: 1" (25 mm) clearance

Dual Units with Remote Switches:

Unit to surface below: 8" (203 mm)

Unit to wall: 3" (76 mm)

Below overshelf: 0" (0 mm) clearance, can be flush to an overshelf

PRODUCT SPECS

Infrared Foodwarmer

The Aluminum Dual Infrared Foodwarmer shall be a Glo-Ray®, manufactured by the Hatco Corporation, Milwaukee, WI 53234 U.S.A.

The Foodwarmer shall be a Glo-Ray model ... , rated at ... watts, ... volts, single phase, and be ... inches (millimeters) in overall width. The Glo-Ray shall consist of an aluminum housing and include four shelf mounting tabs, and 3' (914 mm) conduit with leads.

REMOTE CONTROL ENCLOSURES

Must order one RMB control box per Strip Heater - If RMB2 is used, multiple warmers can be controlled from one box. For more details, see "Choose Remote Box" section listed under "Resources" on the Hatco website, www.hatcocorp.com

Model	Width	Toggle Switches
RMB-3	6" (150 mm)	2 maximum
RMB-7	9.375" (239 mm)	4 maximum
RMB-14	14.375" (366 mm)	6 maximum
RMB-16	16.375" (417 mm)	3 maximum
RMB-20	20.375" (518 mm)	4 maximum
RMB2-1R	11" (279 mm)	1 toggle, 1 infinite, 1 relay, 1 indicator light
RMB2-2R	14" (356 mm)	1 toggle, 1 infinite, 2 relays, 1 indicator light



Model RMB-14E
with infinite controls



RMB-3F
with toggle switch
and indicator light

The infrared heating element shall be tubular metal sheathed. The foodwarmer shall be factory-assembled ready for electrical installation.

Options and accessories shall include adjustable or non-adjustable tubular stand, angle brackets, suspension chain and fittings, sneeze guard and indicator light.

24/7 parts and service assistance (U.S. and Canada only).

HATCO CORPORATION | P.O. Box 340500 Milwaukee, WI 53234-0500 U.S.A.

(800) 558-0607 | (414) 671-6350 | www.hatcocorp.com | equipsales@hatcocorp.com | intlsales@hatcocorp.com