



FLAV-R-SAVOR® LARGE CAPACITY MERCHANDISING CABINETS

Models LFST-48-1X, -2X WFST-1X, -2X

The Hatco large capacity Flav-R-Savor® Heated and Humidified (WFST only) Merchandising Cabinets hold more product at proper serving temperatures than standard size models. Prepare food in advance of peak periods and place product straight from the oven into the full-view cabinets to increase impulse sales. Temperatures range from 80° to 190°F (27° to 88°C).

FLEXIBILITY

Available with an adjustable rack, these cabinets maintain food quality and proper serving temperatures.

LFST models (Non-humidified) holds wrapped or boxed products side-by-side on three shelves for increased product visibility and easy accessibility.

WFST models (Humidified) features a 4-shelf multi-purpose adjustable wire rack capable of holding standard sheet pans 18" x 26" (457 x 660 mm). This flexible rack allows the operator to customize the Flav-R-Savor to fit multiple foodservice uses with slant or horizontal shelves. The WFST-2X has an additional set of French-style doors on the customer side of the unit for easy pass-thru convenience. Optional self-closing doors are available for self-serve applications.

QUALITY

The following features assure the finest performance for years to come:

- Controlled moisturized heat creates a "blanket" effect around the food in the WFST models.
- Tempered glass doors and side panels provide maximum heat retention and allow for full cabinet display.
- Maintains proper serving temperature and keeps food at "just-made" taste and temperatures.
- Shatter-resistant incandescent lights enhance product displays while safeguarding food products from bulb breakage.
- Available in seven *Designer* colors with French-style doors and 6' (1829 mm) cord and plug.
- Stacking kit, merchandising signs, decals, and 4" (102 mm) adjustable legs are available for the WFST models.
- Multi-purpose display racks are included, and are adjustable in 2" (51 mm) increments



Equipment
On Signage Program
Hatcographics.com

LFST-48-2X with 3-shelf multi-purpose rack, sign holders, and optional *Designer* color (Signs not included)



Expanded Merchandising Systems

Stacking kits are available for WFST models to create two separate humidified, heated cases. This utilizes minimum floor space and doubles the display capability by stacking the units.



WFST-1X with 4-shelf multi-purpose rack and accessory decals and pans

Custom Food Decals (WFST models)

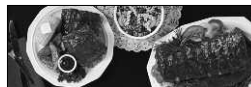

Eye-catching food decals for the side panels. Maximum 3 decals per unit. For daily menu changes, erasable markers may also be used.



WFST-2X with 4-shelf multi-purpose rack, optional *Designer* color and sliding doors and accessory pans



HATCO CORPORATION P.O. Box 340500 Milwaukee, WI 53234-0500 U.S.A.
(800) 558-0607 • (414) 671-6350 • Fax (800) 543-7521 • Int'l Fax (414) 671-3976
www.hatcocorp.com • E-mail: equipsales@hatcocorp.com

Form No. LFST/WFST Spec Sheet

Printed in U.S.A.
April 2012

METAL SHEATHED AIR HEATING ELEMENTS
GUARANTEED AGAINST BURNOUT AND BREAKAGE
FOR TWO YEARS.



FLAV-R-SAVOR® LARGE CAPACITY MERCHANDISING CABINETS

Models LFST-48-1X, -2X WFST-1X, -2X

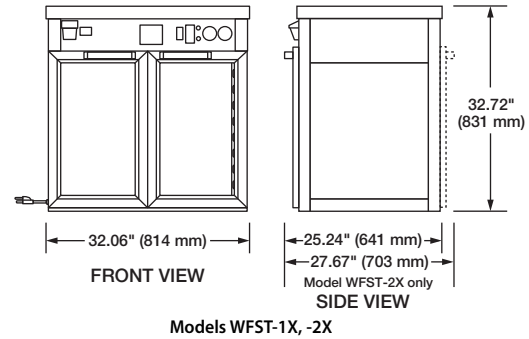
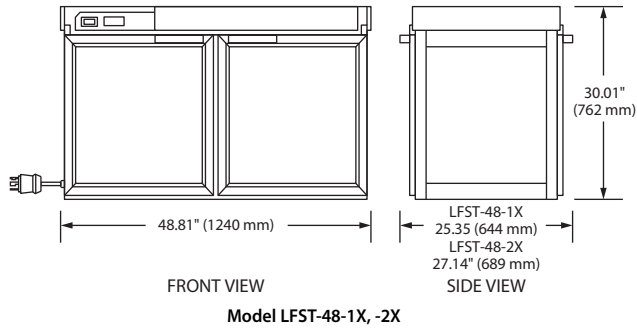

SPECIFICATIONS

Non-Humidified

Model	Type	Rack Style	Shipping Weight
LFST-48-1X	2 Doors	3-Shelf Adjustable	222 lbs. (101 kg)
LFST-48-2X	4 Doors	3-Shelf Adjustable	230 lbs. (104 kg)

Humidified

Model	Type	Rack Style	Shipping Weight
WFST-1X	2 Doors	4-Shelf Adjustable	182 lbs. (83 kg)
WFST-2X	4 Doors	4-Shelf Adjustable	188 lbs. (85 kg)

WATER QUALITY REQUIREMENTS (WFST only)

Water supply in excess of 3.0 grains of hardness per gallon (GPG) (.75 grains of hardness per liter) must be treated and softened before being used. Water containing over 3.0 GPG (.75 GPL) will decrease the efficiency and reduce the operating life of the unit.

Note: Product failure caused by liming or sediment buildup is not covered under warranty.

Display Racks

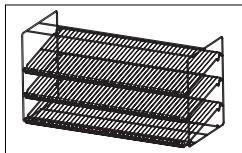

3-Shelf Multi-Purpose Rack – LFST Models
Holds three, half-size sheet pans per shelf

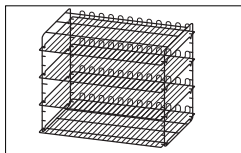

4-Shelf Multi-Purpose Rack – WFST Models
Holds one full-size sheet pan per shelf

DIMENSIONS

LFST-48-1X: 48.81"W x 25.35"D x 30.01"H (1240 x 644 x 762 mm).
 LFST-48-2X: 48.81"W x 27.14"D x 30.01"H (1240 x 689 x 762 mm).
 WFST-1X: 32.06"W x 25.24"D x 32.72"H (814 x 641 x 831 mm).
 WFST-2X: 32.06"W x 27.67"D x 32.72"H (814 x 703 x 831 mm).
 Cabinet Opening – LFST-48-1X, -2X: 44"W x 22"H (1118 x 559 mm).
 – WFST-1X, -2X: 28"W x 21.94"H (711 x 557 mm).

VOLTAGE

LFST-48-1X, -2X: 120/208-240 volts, 2150 watts, 14.6 amps (uses NEMA L14-20P).
 WFST-1X, -2X: 120 volts, 60 Hz, 1790 watts, 14.9 amps (uses NEMA 5-15P, NEMA 5-20P – Canada).
 WFST-1X, -2X: 220 volts, 50/60 Hz, 1750 watts, 8.0 amps (uses CEE 7/7 Schuko plug configuration).
 WFST-1X, -2X: 240 volts, 50/60 Hz, 1790 watts, 7.5 amps (uses BS-1363 plug configuration).

CORD LOCATION

Facing controls, left-hand side panel, lower right corner.

PLUG CONFIGURATIONS

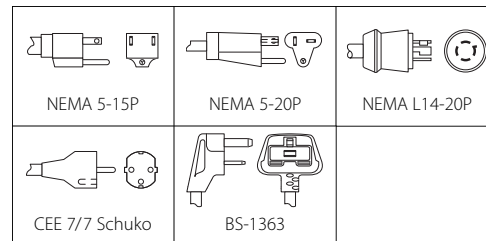

OPTIONS (NOT FOR RETROFIT)

- Designer Colors: Warm Red, Black, Gray Granite, White Granite, Navy Blue, Hunter Green, Antique Copper
- Self-Closing Sliding Doors (WFST-2X only, in lieu of Hinged Doors on one side only)
- Self-Closing French Doors (WFST models only)
- Halogen Bulbs in lieu of Standard Display Lights

ACCESSORIES

- 4" (102 mm) Adjustable Legs (WFST models only)
- Sign Holder (without acrylic window - signs not included) (WFST models only)
- Custom Food and Graphic Decals (3 per set) Chicken, Ribs, or Today's Hot Specials (WFST models only)
- Stacking Kit in Gray or Black (Includes 6" (152 mm) Stainless Steel Legs, Top and Bottom Frame) (WFST models only)
- Full-size Sheet Pans 18" x 26" (457 x 660 mm)
- Half-size Sheet Pans 18" x 13" (457 x 330 mm)

PRODUCT SPECS

Large Capacity Holding and Display Cabinet

The Large Capacity Holding and Display Cabinet shall be a Flav-R-Savor® Model ..., rated at ... volts and ... watts, as manufactured by the Hatco Corporation, Milwaukee, WI 53234 U.S.A.

With 24/7 service (U.S. and Canada only), the LFST cabinet shall have ... doors, incandescent display lights, tempered glass sides, and removable adjustable rack. It shall include a temperature selector dial, On/Off switch, indicating lights, and a 6' (1829 mm) cord with plug attached.

Accessories shall include pans.

With 24/7 service (U.S. and Canada only), the WFST cabinet shall have ... door(s), tempered glass sides, adjustable rack, stacking hardware, and incandescent display lights. It shall include a water reservoir, humidity selector switch, temperature selector dial, On/Off switch, indicating lights, and a 6' (1829 mm) cord with plug attached.

Accessories shall include adjustable legs, pans, merchandising display sign(s), graphic decals, and stacking kit.

HATCO CORPORATION P.O. Box 340500 Milwaukee, WI 53234-0500 U.S.A. • (800) 558-0607 • (414) 671-6350
Fax (800) 543-7521 • Int'l. Fax (414) 671-3976 • www.hatcocorp.com • E-mail: equipsales@hatcocorp.com