



MBGFP48-HG



MBGFP-HG SERIES

Bottom Mounted
 Swinging Glass Door
 Freezer Merchandisers
 With Lighted Sign

MODELS

- MBGFP23-HG
- MBGFP27-HG
- MBGFP48-HG
- MBGFP74-HG

FEATURES

New Glass Door Features:

- Most energy efficient freezer door in the industry – zero heat
- Advanced insulated glass pack construction offers humidity protection up to 74% RH*
- Anti-fog coating means doors are always clear, even during openings and heavy use
- Increased reliability by eliminating electrical components

*Based on lab testing at 75°F ambient temperature and -10°F case temperature

- 24 gauge painted textured galvanized steel interior and exterior
- Standard exterior finishes: Black or white
- Standard interior finish: White with stainless steel floor
- Top backlit graphic panel (standard blank sign applied without graphics)
- 1 3/4" thick state-of-the-art, foamed-in-place "zero ODP" polyurethane insulation provides high R-value
- Adjustable legs for leveling
- Four adjustable heavy-duty epoxy-coated shelves per door adjustable on 1/2" pilasters
- Standard price tag molding for shelves
- Merchandiser profile matches other Fusion Plus™ refrigerator and freezer models

DOORS

- Auto-close, triple pane
- Contemporary style black door frame and handles
- Heavy-duty universal workflow handles
- Easily replaceable snap-in magnetic vinyl door gaskets

REFRIGERATION

- Self-contained bottom mount refrigeration system designed for optimum energy efficiency and low noise
- ENERGY STAR qualified, may be eligible for rebate programs
- Top mounted, low profile interior evaporator housing
- Energy-free condensate removal
- Refrigerant: R-404A
- Refrigerant controlled by thermostatic expansion valve
- Temperature range: 5° to -15°F (-18° to -26°C)

WARRANTY

- **Standard limited three year parts and labor**
- **Additional two year coverage on compressor part**

CONSTRUCTION

- Standard interior LED lighting
- Standard programmable electronic controller featuring:
 - Audible and visual alarm
 - Eliminates room thermostat, defrost termination/fan delay control, defrost timer and digital thermometer or other temperature indicator

OPTIONS

- Casters
- Additional shelving

TECHNICAL SPECIFICATIONS

MODEL	DIMENSIONS (in.)			DIMENSIONS (mm)			VOLTS	AMPS	UNIT H.P.	NO. OF DOORS	NO. OF SHELVES	SHELF SIZE (in.)	WEIGHT CAP. PER SHELF (LB/KG)	CAP. CU. FT.	SHIP WT. (LB/KG)
	L	D*	H	L	D*	H									
MBGFP23-HG	27	32 ¹ / ₄	79	686	819	2007	115	7.5	1/2	1	4	22 ¹ / ₂ L x 21 ¹ / ₂ D	92/42	22.1	365/166
MBGFP27-HG	30	32 ¹ / ₄	79	762	819	2007	115	7.5	1/2	1	4	25 ¹ / ₂ L x 21 ¹ / ₂ D	105/48	25.0	380/173
MBGFP48-HG	52	32 ¹ / ₄	79	1321	819	2007	115	12.3	3/4	2	8	23 ¹ / ₂ L x 21 ¹ / ₂ D	92/42	45.7	575/261
MBGFP74-HG	78	32 ¹ / ₄	79	1981	819	2007	115/ 208-230**	12.8	1	3	12	23 ¹ / ₂ L x 21 ¹ / ₂ D (ends), 25 ¹ / ₂ L x 21 ¹ / ₂ D (center)	92/42 (ends), 105/48 (center)	70.2	770/350

*Includes door handle and rear drainline cover. **208-230/60/1 also requires neutral and safety ground wire.

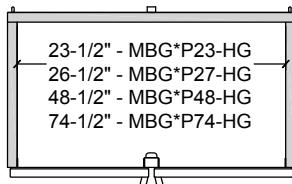

PLAN VIEW

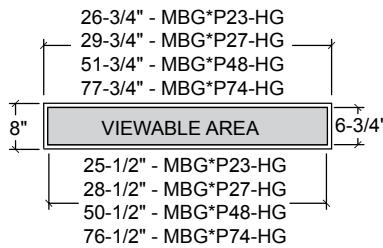

GRAPHIC PANEL DIMENSIONS

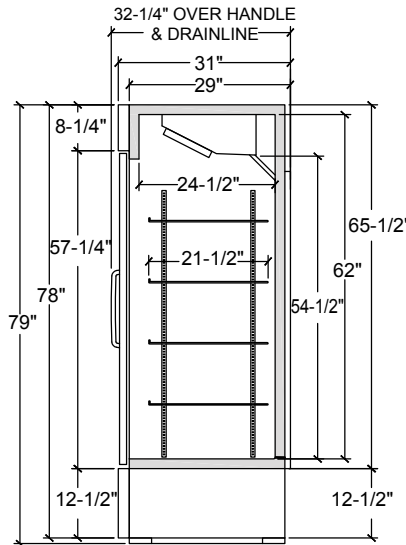

SIDE VIEW

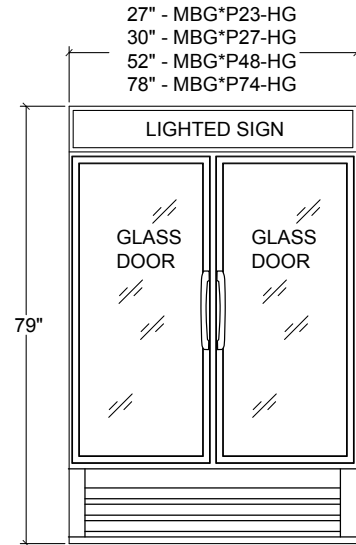

ELEVATION VIEW

LISTINGS



- Listed under NSF-7 for the storage and/or display of packaged food
- Meets Canadian energy efficiency regulations

HOOKUP

All models except MBGFP74-HG via plug in, 10 foot long, flexible three wire 14/3 cord with molded plug.

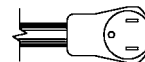

NEMA 5-15P (MBGFP23-HG & MBGFP27-HG)

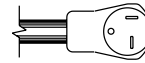

NEMA 5-20P (MBGFP48-HG)

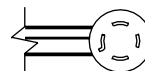

NEMA L14-20P (MBGFP74-HG)

MBGFP74-HG via plug in, 10 foot long flexible four wire 208-230v 14/4 cord with neutral and ground wires and molded plug.

BID SPECIFICATIONS

Item no. MBGFP _____ -HG. Provide _____ Bottom Mounted Swinging Glass Door Freezer Merchandiser(s) With Lighted Sign, Master-Bilt[®] model no. MBGFP _____ -HG.

Merchandiser will be constructed of 24 gauge painted textured galvanized steel interior and exterior. Standard equipment will include interior LED lighting, programmable electronic controller system, top backlit

graphic panel and four epoxy-coated shelves per door adjustable on 1/2" pilasters.

Doors will be auto-close, triple pane with anti-fog coating on inside.

Refrigeration system will be self-contained and designed for optimum energy efficiency and low noise. Also standard will be an energy-free condensate removal system.

The refrigerant will be R-404A and the

temperature range will be 5° to -15°F (-18° to -26°C).

Merchandiser to have standard limited three year parts and labor warranty with additional two year coverage on compressor part. Merchandiser to be UL and C-UL listed, UL EPH classified, and ENERGY STAR qualified. Merchandiser will also meet Canadian energy efficiency regulations.

NOTE: Cabinet designed for optimum performance in air-conditioned area at 75°F ambient and 55% relative humidity. All specifications subject to change without notice.