



MBR49-G



## MBR-G SERIES

### Bottom Mounted Glass Door Reach-In Refrigerators

#### MODELS

- MBR23-G
- MBR49-G
- MBR72-G

### FEATURES

#### CONSTRUCTION

- Stainless steel exterior on front, sides and doors
- Exterior top, bottom and back are galvanized steel
- Interior liner is stainless steel
- Foamed-in-place with low ODP polyurethane insulation
- Standard electronic controller with these features:
  - Digitally displays inside temperature in either °F or °C
  - Allows user to monitor and adjust temperature set point within normal temperature range
  - Visual and audible door open alarm
  - Clean condenser alarm (displays “CL” every 6 months)
  - Decreases service time and calls
- Wall thickness:
  - Sides ..... 1<sup>7</sup>/<sub>8</sub>"
  - Top and back.....2"
  - Bottom ..... 2<sup>3</sup>/<sub>8</sub>"
- 4" diameter casters

- Four casters on one- and two-door models and six on three-door models (two casters on each model are locking type)
- Four adjustable heavy-duty shelves per door

#### DOORS

- Heavy-duty pull handles
- Self-closing at 96°
- Hold open feature at 110°
- Individual door locks
- Self-adjusting magnetic gaskets
- Interior LED lighting
- Anti-condensate heater wires on door openings
- Standard door swing configuration:
  - MBR23-G ..... hinged right
  - MBR49-G ..... left doors hinged left, right doors hinged right
  - MBR72-G ..... left doors hinged left, middle doors hinged right, right doors hinged right
- Door width:
  - MBR23-G ..... 27<sup>1</sup>/<sub>8</sub>"
  - MBR49-G ..... 27<sup>1</sup>/<sub>8</sub>"
  - MBR72-G ..... 25<sup>3</sup>/<sub>8</sub>"

#### REFRIGERATION

- Self-contained bottom mount refrigeration system
- Capillary tube controls refrigerant flow
- Automatic defrost
- Fabric condensation kit uses wicks to draw condensate from the drain pan for faster removal
- Refrigerant:
  - MBR23-G & MBR49-G ..... R-134a
  - MBR72-G ..... R-404A
- Temperature range: 32° to 40°F (0° to 4° C)

#### WARRANTY

- **Standard limited three year parts and labor**
- **Additional two year coverage on compressor part**

#### OPTIONS

- Extra wire shelves
- 6" adjustable feet
- Pan rack

### TECHNICAL SPECIFICATIONS

MODEL	DIMENSIONS (in.)			DIMENSIONS (mm)			VOLTS	AMPS	UNIT H.P.	NO. OF DOORS	NO. OF SHELVES	STANDARD SHELF SIZE (in inches)	CAP. CU. FT.	SHIP CU. FT.	SHIP WT. (LB/KG)
	L	D*	H*	L	D*	H*									
MBR23-G	27 <sup>3</sup> / <sub>8</sub>	32 <sup>7</sup> / <sub>8</sub>	83 <sup>3</sup> / <sub>4</sub>	695	835	2127	115	7.5	1/3	1	4	22 <sup>3</sup> / <sub>4</sub> x 22 <sup>7</sup> / <sub>8</sub>	23.0	46.1	308/140
MBR49-G	55 <sup>1</sup> / <sub>4</sub>	32 <sup>7</sup> / <sub>8</sub>	83 <sup>3</sup> / <sub>4</sub>	1400	835	2127	115	7.5	1/3	2	8	22 <sup>3</sup> / <sub>4</sub> x 24 <sup>7</sup> / <sub>8</sub>	49.0	88.5	473/215
MBR72-G	78	32 <sup>7</sup> / <sub>8</sub>	83 <sup>3</sup> / <sub>4</sub>	1980	835	2127	115	8.5	3/5	3	12	**	72.0	124.1	646/294

\*Depth includes door handle, height includes casters. \*\*LH & RH shelf for 3 section models is 22<sup>3</sup>/<sub>4</sub>" x 22<sup>7</sup>/<sub>8</sub>", center shelf is 22<sup>3</sup>/<sub>4</sub>" x 25<sup>3</sup>/<sub>4</sub>".

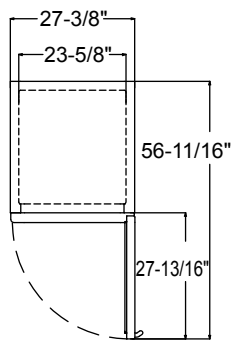

**MBR23-G**  
PLAN VIEW

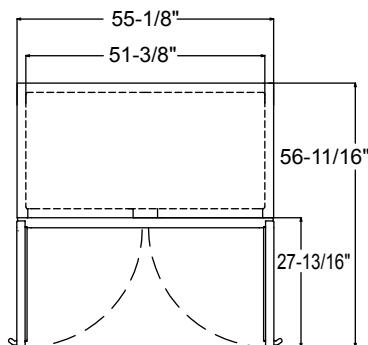

**MBR49-G**  
PLAN VIEW

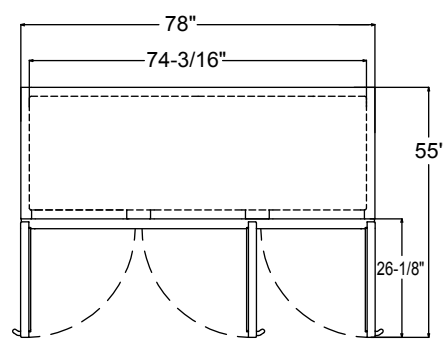

**MBR72-G**  
PLAN VIEW

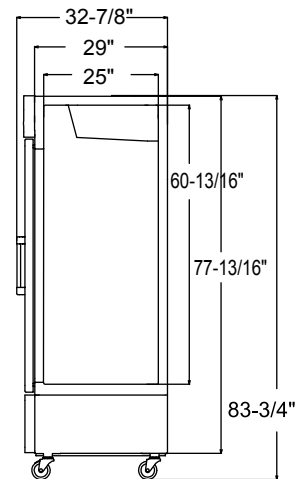

**SIDE VIEW**

### LISTINGS



### HOOKUP

Via plug in, 9.8 foot long flexible three wire 14/3 cord with molded plug.

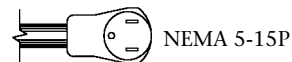

### BID SPECIFICATIONS

Item no. MBR \_\_\_\_\_-G. Provide \_\_\_\_\_ Bottom Mounted Glass Door Reach-in Refrigerator(s), Master-Bilt® model no. MBR \_\_\_\_\_-G.

Reach-in will feature rounded corner construction with stainless steel interior and exterior. Top, bottom and back will

be galvanized steel. Reach-in will also be equipped with an electronically controlled monitoring system with door alarm function.

The refrigeration system will be bottom mounted and self-contained. MBR23-G & MBR49-G models will use R-134a refrigerant. MBR72-G model will use R-404A. The

temperature range will be 32° to 40°F (0° to 4° C).

Reach-in to have standard limited three year parts and labor with additional two year coverage on compressor part.

Reach-in to be ENERGY STAR® qualified & UL, C-UL and ETL sanitation listed.

**NOTE:** Cabinet designed for optimum performance in air-conditioned area at 75°F ambient and 55% relative humidity. All specifications subject to change without notice.