

3240 Impinger® Conveyorized Oven

Project _____
Item _____
Quantity _____
CSI Section 11400
Approved _____
Date _____

Models

- 3240 Natural Gas
- 3240 LP Gas
- 3240 Electric



Lincoln Impinger Conveyor Ovens are the premier continuous cook platforms for the food service industry. Using the latest advancements in air impingement technology, Impinger ovens allow for rapid heating, cooking, baking, and crisping of foods, typically done two to four times faster than conventional ovens.

Standard Features

- **FastBake** Technology
- 40" Baking Chamber
- Stainless Steel Exterior & Interior Construction
- Front-Facing Digital Control Panel
- Removable Large Front Panel for Easy Access
- Sandwich Door Standard
- Stackable Up To Three (3) High
- Crumb Trays

Benefits

- **FastBake** Technology designed to bake up to 35% faster than other conveyor ovens without increased noise levels or loss of product quality!
- Faster bake times improve time of service
- Advanced air impingement technology enhances bake quality and uniformity
- Improved product flow during cooking reduces operation costs
- Research and applications support for continued operational success
- **Manitowoc KitchenCare** helps protect and maintain your foodservice equipment, ensuring that it performs like it should throughout its lifecycle.

Specifications

Easy to Operate

Digital controls with single on/off power switch
 Microprocessor controlled bake time/conveyor speed
 Improved view vacuum fluorescent readout displays set temperatures in degrees (F° or C°), conveyor belt speed, thermostat indicator light, and diagnostic messages for easy troubleshooting
 All settings are automatically locked out to eliminate accidental changes

Easy to Clean

Front door for easy cleaning and removal of finger assemblies
 Conveyor is removable through the right side opening

Optional Features

Flexible gas connector
 Split Belt
 Vented Crumb Trays
 High or Low Stand
 Folding Conveyor



3240 Impinger® Conveyorized Oven

Gas Supply Pressure Recommendations

Gas Type	Supply (Inlet) Pressure (mbar)	Recommended Minimum Gas Pipe Size
Natural	7-14" WC (2.2 kPa / 22.4 mbar - 3.5 kPa / 34.9 mbar)	2" (51 mm)
LP	11-14" WC (2.7 kPa / 27.36 mbar - 3.5 kPa / 34.9 mbar)	2" (51 mm)

*Gas supply pressures are dependent on local gas type and on all applicable local codes. Agency approved flexible connection to each oven must be minimum 3/4" (19 mm) NPT and length must not exceed six (6) feet (1829 mm).

Electrical Service

Each oven deck requires voltage, phase and hertz as indicated by model number. Neutral must be grounded at electrical service and receptacle properly polarized. Gas 120V units have a cord with NEMA 5-15 plug. All other models have terminal block connections. It is recommended that a separate circuit breaker be provided for each oven deck.

Recommended Minimum Clearances

Rear of oven to combustible surface: 6" (152 mm). Clearance on right side from other cooking equipment: 24" (610 mm). Clearance required to remove conveyor for cleaning: 11' (3553 mm).

Warranty

All new Impinger ovens installed in the United States and Canada come with a two (2) year parts and labor warranty starting from the date of start-up/check-out. All ovens installed in locations other than in the US and Canada are warrantied for one (1) year parts and ninety (90) days labor starting from the date of start-up/check-out. Start-up/check-out must occur within 24 months of date of manufacture.

General Information

All 3240 Models	Length	Depth (Including Handle)	Height Single	Height Double Stacked	Height Triple Stacked
Dimensions include stands with 6" casters.	77.6" (1971 mm)	60.1" (1527 mm)	46" (1168 mm)	64.6" (1641 mm)	71.8" (1824 mm)

3240-000-L-K2300

**Language/Agency/
(Electric For Gas Ovens Only)**

This is only a partial list of available configurations

0: English/French/US/120/60/1

1: English/French/US/120/60/1*

2: English/CE/230/50/1

B: French/CE/230/50/1

D: Italian/CE/230/50/1

E: Spanish/CE/230/50/1

G: Spanish/US/120/60/1

J: Danish/CE/230/50/1

*Export Crating

Finger Setup

K2350 = General Market L to R

K2351 = General Market R to L

Heating Type

N = Natural (120,000 BTU/Hr)

L = LP (120,000 BTU/Hr)

T=Butane/Towne/Other

Electric (For Non-Gas Ovens):

B: 400Y/3/50

R: 208/3/60

D: 380Y/3/50

S: 480/460/440/3/60

G: 415Y/3/50

V: 240/3/60

W: 220/3/60

Belt Type

0 = Solid Belt

5 = Split Belt

Customer Configuration

0 = General Market

3240

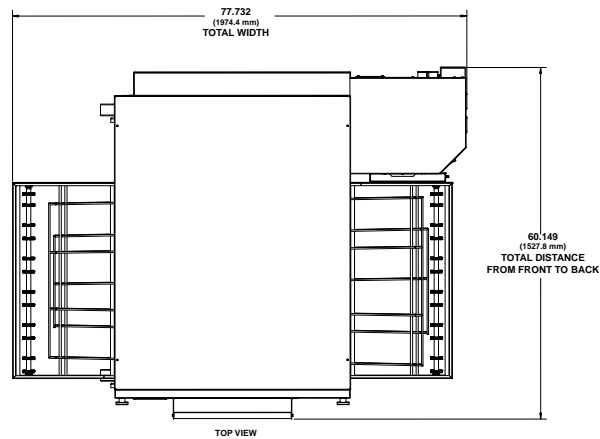
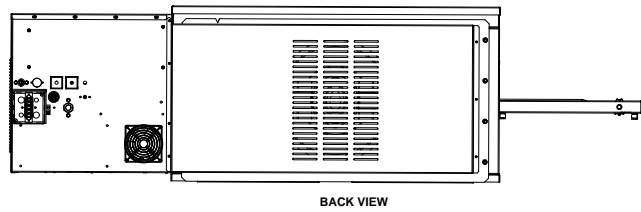
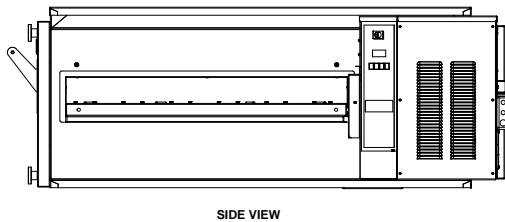
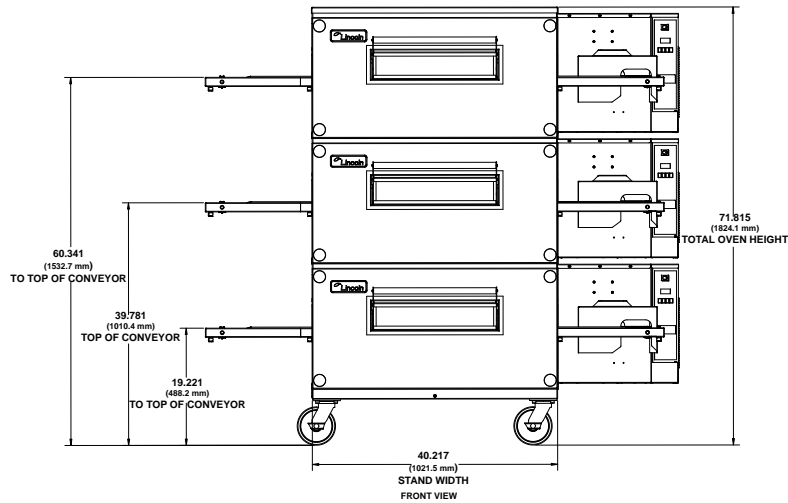
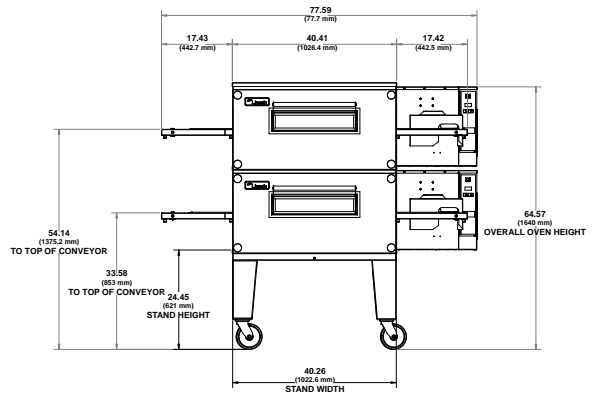
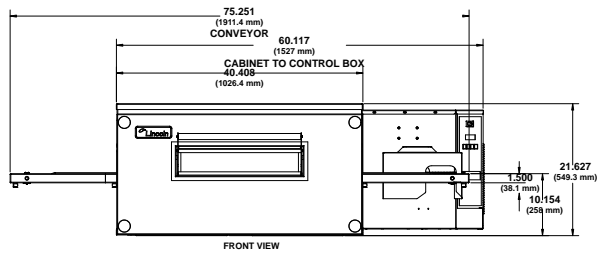

Capacity Estimates | Pies Per Hour

Pie Size	BAKE TIME								
	3 min.	3½ min.	4 min.	4½ min.	5 min.	5½ min.	6 min.	6½ min.	7 min.
12" (30 cm)	182	155	135	120	108	99	90	84	78
14" (36 cm)	115	99	87	88	69	63	58	53	50
16" (41 cm)	101	87	76	67	61	55	51	47	44

Ventilation Requirements

Ventilation is required for this conveyor oven. Hood specification, design and installation must meet IMC 2009/2012 Sec 5.7 and other requirements. Pizza Ovens are Light Duty Appliances for determining code compliance. If a Type I hood with Fire Suppression is required, proper interlocks of controls for the oven and the vent hood must be approved per IMC 2012 or equivalent. The vent/extraction application for this oven and overall final installation is determined by the authority having jurisdiction per NFPA-96. Carbon monoxide levels must be less than 10 ppm in the space around the oven.

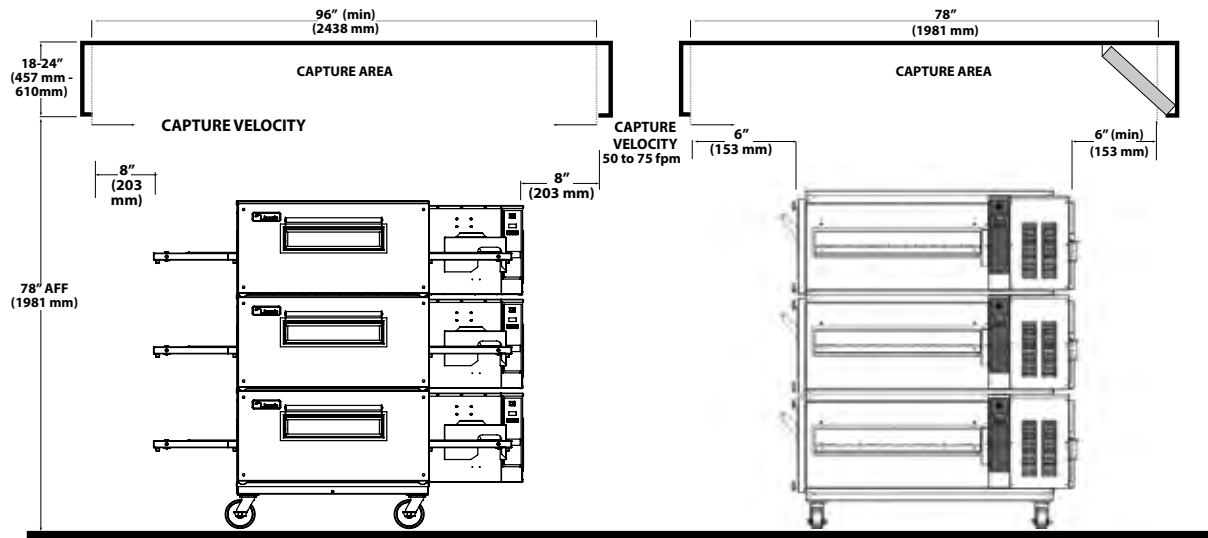

This information is shown as a guideline for ventilating the Impinger 3240 Ovens:

1. Use of a Type II hood is permitted with actual product use defined as Light Duty according to the most current International Mechanical Code. However, application and overall final installation is determined per local codes.
2. Recommend 1000-1600 CFM Exhaust Rate to provide complete extraction of vapors and heat.
3. The capture velocity across the lower edge of the canopy must be sufficient to direct cooking vapors and oven heat into the hood. This is to be inward 50 to 75 FPM at sides and front. This capture velocity is to be verified on site with all ovens operating at set temperature.
4. Certified grease extraction filters should be used at the exhaust area of the hood.
5. Dimensions shown are for ovens without extension shelves. The outside end of the conveyor frame should be a minimum of 8 inches inside the canopy as shown.
6. The ovens are to be centered in the canopy space left-to-right and front-to-back if possible.
7. A minimum 6 inch space behind the oven is recommended for utilities.
8. If make-up air is provided outside of the canopy through diffusers, they should be directed straight down... not at the oven. Room air diffusers must not be directed toward the oven and should be positioned a minimum of 3 ft. from the perimeter of the hood.

Welbilt reserves the right to make changes to the design or specifications without prior notice.