

COUNTERTOP WARMER

Keeps pre-cooked and pre-warmed foods at desired serving temperature.

Standard Features:

- Special heating element design generates even heat distribution – no hot spots
- High quality brushed stainless steel exterior and polished stainless steel heat well
- Easy to use adjustable temperature control
- Recommended for use with water but can be used without water
- Heat release vents
- Skid-resistant feet
- "Power-On" light
- One Year Limited Warranty
- UL Safety and Sanitation

Product Specifications:

- Model Number: 1023242 (509FC)
- UPC Number: 8 38476 00509 6
- Unit Dimensions (exterior): 22-1/2" L x
14-1/2" W x 9-1/2" H
- Unit Dimensions (interior): 19-15/16" L x
12-15/16" W x 6-1/4" H
- Electrical Information: Equipped with 60" three wire grounded cord with a standard three pronged male plug
- Electrical Specifications: 120V / 1200 Watts / 10 Amps
- Unit Weight: 15 lbs.
- Carton Dimensions: 25" L x 16-5/16" W x 10-3/4" H
- Carton Cube: 2.5 ft.³
- Ship Weight: 18 lbs.

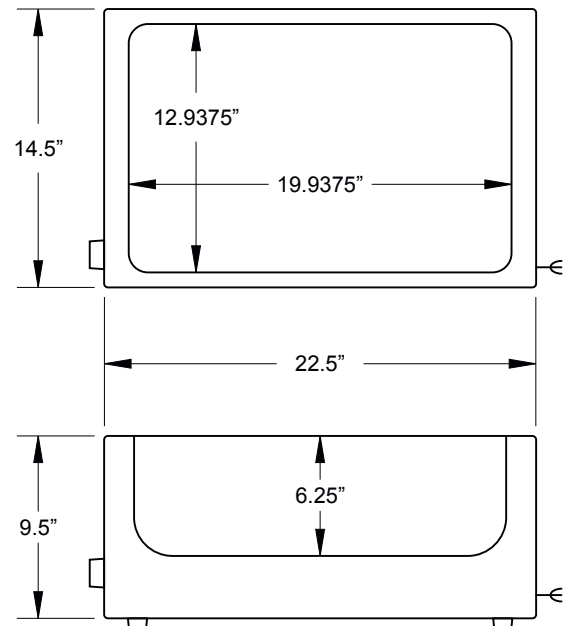

Customer Service:

- Call Toll Free @ 1-800-945-4589 ext. 112
- Fax @ 216-663-3823
- Visit us on the Web @ www.FusionCommercial.com
or www.tomlinsonind.com

