

Project _____

Item Number _____

Quantity _____

7512



7512 Value Slicer

Model:

➤ 7512: 1/2hp Manual Slicer



CERTIFIED BY NSF INTERNATIONAL TO MEET
AND EXCEED THE NSF/ANSI 2012 STANDARDS

Value Series Slicer

Features:

- Medium duty, moderate volume slicer
- Maximum duty 4 hours a day
- Capable of slicing moderate amounts of cheese
- Unique drip tray fence redirects liquids away from controls and operator towards distinctive concave base casting for easy cleaning
- Ergonomic comfort design operation
- Powerful 1/2 hp motor standard
- Adjustable slice thickness from 0 to 7/8"
- Easily removable sharpener for cleaning
- Quick and simple disassembly of carriage and feed grip for easy and thorough cleaning
- Sanitary polished and anodized aluminum construction
- Permanently mounted protective edge guard for operator safety
- Heavy duty 3-1/2 lb gravity fed grip

12" Precision slicing German hollow ground blade
Unique smooth curve transitions to redirect liquids away from controls and operator
Easily detachable carriage for easy cleaning

Optional Accessories:

- Stainless steel blade
- Heavy duty clear plastic cover
- Stainless steel vegetable chute
- Sturdy stainless steel stand

Warranty:

- One year, on-site parts and labor

Univex Corporation



WE RAISE THE BAR. WE SET THE STANDARD.

Value Series Slicer

7512

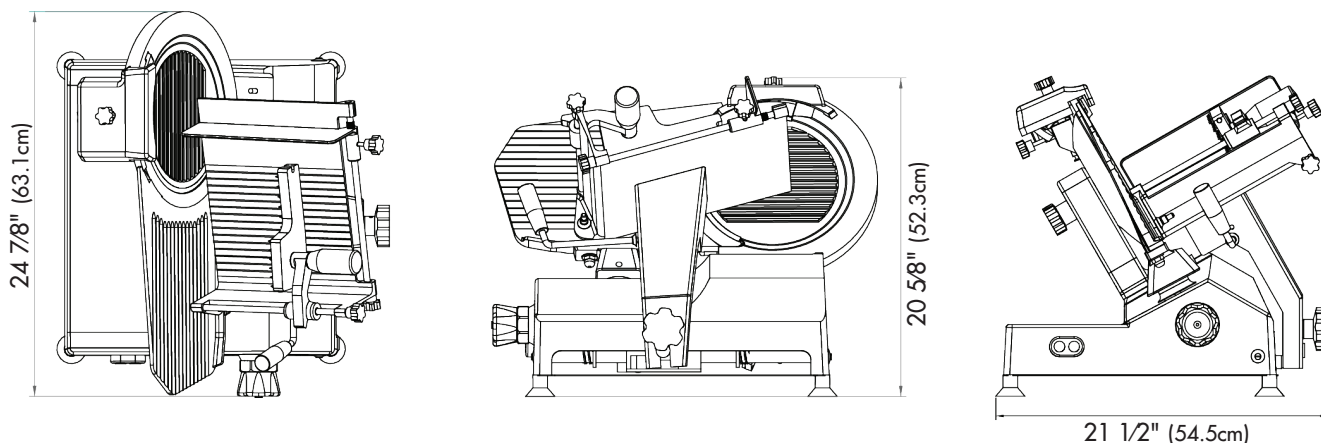

Controls: Manual slice thickness knob, push button on/off, attached blade sharpener

Drive Assembly: Belt driven

Blade diameter: 12" (30.4cm) razor sharp blade

Blade RPM: 345 RPM

Maximum slice thickness: .875" (2.2cm)

Maximum product size: Rectangular: 9.25" x 7.5" (24.5cm x 19cm)
Square: 7.5" x 7.5" (19cm x 19cm)
Round: 8" (20.3cm)

Construction: Anodized, cast aluminum body for durability and stunning looks

Nema #: 5-15-P

Electrical Information (60Hz)					
	Voltage	Phase	Amps	RPM	hp(kW)
Standard Voltage	115	1	4.0	1680	1/2 (.37)
Optional Voltage	208-240	1	2.5	1680	1/2 (.37)

Carriage Stroke
11" (28cm)

Shipping Information		
Net Weight	Shipping Weight	Overall Shipping Dimensions
98.1lbs. (44.5Kg)	106lbs. (48.1Kg)	23" (55.9cm) H x 20" (50.8cm) W x 27" (66cm) D



Univex Corporation
www.Univexcorp.com

3 Old Rockingham Rd
Salem, NH 03079
United States of America

TEL: (800)258-6358
INTL TEL: (603)893-6191
FAX: (800)356-5614
INTL FAX: (603)893-1249