

REFRIGERATOR MANUFACTURER
Turbo air
 more durable, efficient, beautiful

4184 E. Conant St.
 Long Beach, CA 90808
 Tel. 310-900-1000
 Fax. 310-900-1077
www.turboairinc.com

Project :
 Model # :
 Item # : Qty :
 Available W/H :
 Approval :

Beer Dispensers

*Underbar Equipment
 Super Deluxe Series*

Model : TBD-3SD/SB



TBD-3SD



TBD-3SB



Easy to Clean Air Filter
 Front Access

- Does not include keg couplers

≡ FEATURES & BENEFITS ≡

■ **Equipped with easy-to-clean Air Filter**

The accumulation of dust in the condenser causes failures and/or breakdowns in refrigeration. Refrigeration operate normally until they accumulate a certain amount of dust. When they reach over their limit, performance will drop rapidly, resulting in damages and possible disposal of stored goods. This is why all refrigeration manufacturers require the condenser to be cleaned at least once a month for warranty to remain valid. Fortunately for Turbo Air, this process is simplified due to the frontal access air filter device. Users only need to pull out the filter and vacuum lightly to remove the dust. Simply place it back into position when complete.

■ **Efficient refrigeration system**

Turbo Air's refrigerators are designed with oversized and balanced R-134A (CFC Free) refrigeration systems. These include efficient evaporators and condensers for faster cooling and greater efficiency.

■ **Stainless steel cabinet construction**

Super Deluxe (SD) models boast a stainless steel exterior (except galvanized steel back and bottom). SB models are attractive wear-resistant black vinyl exterior. Heavy gauge stainless steel countertop is perfect for sanitation and durability. Interior is stainless steel except galvanized steel top. Turbo Air Beer Dispenser model guarantees utmost in cleanliness and long product life. It also can add a touch of style to the most refined setting.

■ **Forced air cooling system**

Fast cooling and balanced temperature throughout the cabinet.

■ **High-density polyurethane insulation**

■ **3" diameter stainless steel insulated beer columns**

■ **Ergonomically designed doors**

Customers' fatigue fades away with easy grip handles and doors that open effortlessly. These features along with self-closing doors make this the ultimate choice in customer convenience.

■ **Side mount compressor unit**

By positioning the compressor on the side of the unit, refrigerators can now be serviced without being moved. Our innovative, front breathing feature also allows this model to provide high efficiency in narrow spaces.

■ **LED lighting interior**

■ **Refrigerator holds 33°F ~ 38°F for the best in beverage preservation**

‡ ENERGY STAR rated models



Model	Swing Door	1/2 Barrels	HP	AMPS	Crated Weight (lbs.)	L x D x H† (inches)
TBD-3SD ‡	2	3	1/3	7	338	69 1/8 x 27 1/8 x 37
TBD-3SB ‡	2	3	1/3	7	348	69 1/8 x 27 1/8 x 37

Model : TBD-3SD/SB

ELECTRICAL DATA	
Voltage	115/60/1
Plug Type	Ⓜ NEMA 5-15P
Full Load Amperes	7
Compressor HP	1/3
Refrigerant	R-134A
Cord Length (ft.)	9
Lamp (w)	25W
DIMENSIONAL DATA	
Capacity (1/2 Barrels)	3
Ext. Length Overall (in.)	69 1/8 (1758mm)
Ext. Depth Overall (in.)*	27 1/8 (691mm)
Ext. Height Overall (in.)†	37 (940mm)
Net Weight (lbs.)	298
Gross Weight (lbs.)	338/348
# of Swing Door	2

Design and specifications subject to change without notice.
Actual shipping weight may differ due to extra packing materials for product protection.
* Depth does not include 2" for cap catcher or 2" for rear spacers.
† Height does not include 5" for caster height.

■ **WARRANTY : 3 Year Parts and Labor Warranty
Additional 2 Year Warranty on Compressor**

- Double faucet beer tower standard
- Door locks standard
- Self-contained system
- 4" dia. swivel casters standard
- 2" dia. casters available (optional)
- 6" height adjustable legs available (optional)

■ **OPTIONAL ACCESSORIES :**

- 2" caster for underbar series, 1/2" diameter: P0165B0100 (non-brake), P0165B0110 (w/ brake)
- 6" adjustable stainless steel leg: P012P0100

PLAN VIEW

(unit : inch)

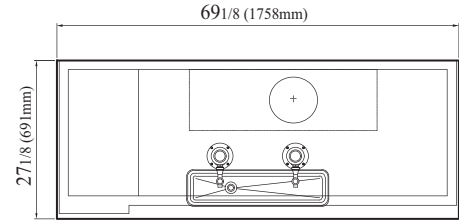

TOP VIEW

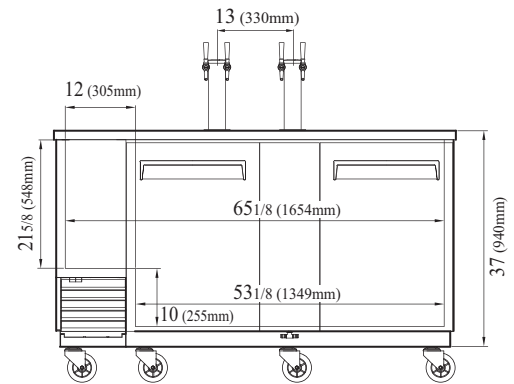

FRONT VIEW

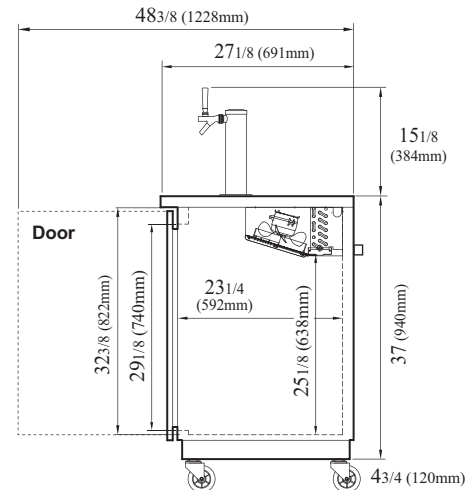

SIDE VIEW

Ver.201601

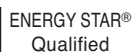

- Turbo Air : 800-627-0032
- GK : 800-500-3519
- Warranty : 800-381-7770
- AC : 888-900-1002

