

REFRIGERATOR MANUFACTURER
Turbo air
 more durable, efficient, beautiful

4184 E. Conant St.
 Long Beach, CA 90808
 Tel. 310-900-1000
 Fax. 310-900-1077
www.turboairinc.com

Project :	
Model # :	
Item # :	Qty :
Available W/H :	
Approval :	

Swing Door Merchandisers

Glass Door Merchandisers
 Refrigerators

Model : TGM-22RV-N6
TGM-22RVB-N6

≡ FEATURES & BENEFITS ≡

- **Hydrocarbon refrigerants (R-600a)**
 With innovative and eco-friendly technology, Turbo Air brings you hydrocarbon refrigerators designed to meet DOE's Energy Conservation Standards in 2017 and to use EPA's SNAP Program approved HC refrigerants. Hydrocarbon refrigerants do not deplete the ozone layer and have very low contribution to global warming (ODP-0, GWP-3).
- **Hot gas condensate system**
 Through Turbo Air's creative innovation, the condensate system surfaces have been specially treated to resist corrosion. This not only increases efficiency without the risk of refrigerant leakage from corrosion, but also prevents the overflow of condensate water.
- **LED advertising panel**
 LED lighting offers 5 times longer lasting life than fluorescents and conserves energy as well.
- **Double pane glass doors with Low-E glass**
 Energy saving double pane glass doors are equipped with Low-emissivity glass, which reduces outer heat gain and decreases energy consumption. It enhances energy efficiency and minimizes condensation. Lightweight door construction also reduces door maintenance and bushing wear, which in turn facilitates smoother door opening.
- **High-density polyurethane insulation**
 The entire cabinet structure and solid doors are foamed-in-place using high density, HCFC free polyurethane insulation.
- **Adjustable, heavy duty, PE (polyethylene) coated wire shelves**
- **LED interior lighting**
- **Refrigerator holds 33°F ~ 38°F for the best in beverage preservation**



Model	Swing Door	CU./FT.	#of Shelves	HP	AMPS	Crated Weight (lbs.)	L x D x H (inches)
TGM-22RV(B)-N6	1	20.3	4	1/5	2.2	243	28 3/4 x 27 5/8 x 79 7/8

Model : TGM-22RV(B)-N6

ELECTRICAL DATA	
Voltage	115/60/1
Plug Type	Ⓜ NEMA 5-15P
Full Load Amperes	2.2
Compressor HP	1/5
Cord Length (ft.)	7
Refrigerant	R-600a
DIMENSIONAL DATA	
# of Doors	1
Net Capacity (cu. ft.)	20.3
Ext. Length Overall (in.)	28 ³ / ₄ (732mm)
Ext. Depth Overall (in.)*	27 ⁵ / ₈ (702mm)
Ext. Height Overall (in.)	79 ⁷ / ₈ (2028mm)
Int. Length Overall (in.)	24 ¹ / ₈ (613mm)
Int. Depth Overall (in.)	23 ⁵ / ₈ (600mm)
Int. Height Overall (in.)	62 ¹ / ₈ (1580mm)
Net Weight (lbs.)	225
Gross Weight (lbs.)	243
# of Shelves	4
Shelf Size (LxD) (in.)	25 ¹ / ₂ x 19 ³ / ₈
Bottle Capacity	280 (full)

Design and specifications subject to change without notice.
Actual shipping weight may differ due to extra packing materials for product protection.
* Depth does not include 1-3/8" for door handle.

■ **WARRANTY : 2 Year Parts and Labor Warranty
Additional 3 Year Warranty on Compressor**

■ **STANDARD FEATURES**

- Anti-corrosion coated evaporator
- White color cabinet & black color frame on door
- Black color cabinet available

■ **OPTIONAL ACCESSORIES :**

- 2.5" caster 1/2" diameter & 13 TPI (special stem nuts required, sold in separate): 30265H0100 (non-brake), 30265H0200 (w/ brake)
 - 4" caster, 1/2" diameter & 13 TPI (special stem nuts required, sold in separate): G8F6500101 (non-brake), G8F6500201 (w/ brake)
 - Special stem nut for caster installation (EA): 30260K0200 (1/2", 13 thds)
 - Additional PE coated wire shelf: 30278K0600
 - Gravity feed shelf: 30278H0200
 - Price tag channel: P0122K5200 (21"L)
- White and black color cabinet available

Ver.20190103

PLAN VIEW

(unit : inch)

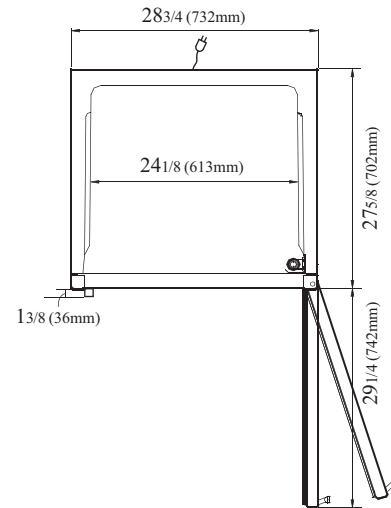

PLAN VIEW

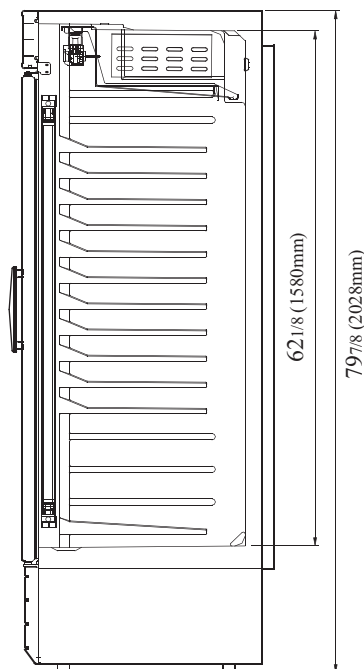

SIDE VIEW

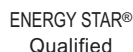

- Turbo Air : 800-627-0032
- GK : 800-500-3519
- Warranty : 800-381-7770
- AC : 888-900-1002

