

REFRIGERATOR MANUFACTURER
Turbo air
 more durable, efficient, beautiful

4184 E. Conant St.
 Long Beach, CA 90808
 Tel. 310-900-1000
 Fax. 310-900-1077
www.turboairinc.com

Project :	
Model # :	
Item # :	Qty :
Available W/H :	
Approval :	

Ice Cream Freezer

*Ice Cream Merchandisers
 Horizontal / Chest Freezers*

Model : TSD-60CF



≡ FEATURES & BENEFITS ≡

■ **Environmentally friendly, efficient refrigeration system**

Turbo Air's freezers are designed with oversized and balanced environmentally friendly R-134A (CFC Free) refrigeration system. These include large evaporators and condensers for faster freezing and greater efficiency throughout the cabinet.

■ **Tempered, energy-saving, low emissivity glass sliding top**

Reduced outer heat gain and lowers energy consumption. It enhances energy efficiency and minimizes condensation.

■ **Attractive curved glass lids**

Optimize eye-catching display and impulse sales. Economical size and design for convenient access and fast service in high traffic area.

■ **Easy temperature control mode is energy efficient**

There is no need to reach inside the freezer to control the temperature. External temperature control knob allows easy adjustment and keeps cold air inside saving energy.

■ **High-density polyurethane insulation**

The entire cabinet structure is foamed-in-place using high density, CFC free polyurethane insulation.

■ **Manual defrost system**

■ **Wire baskets come standard**

■ **White, anti-rust coating on the exterior reduces fingerprints**

■ **Freezer holds -9°F ~ 11°F for the best in frozen food preservation**



Model	Sliding Door	CU./FT.	Baskets	HP	AMPS	Crated Weight (lbs.)	L x D x H* (inches)
TSD-60CF	2	11.2	3	1/3	3.5	160	51 x 23 3/8 x 32 5/8

Model : TSD-60CF

ELECTRICAL DATA	
Voltage	115/60/1
Plug Type	Ⓜ NEMA 5-15P
Full Load Amperes	3.5
Compressor HP	1/3
Cord Length ft.	7
Refrigerant	R-134A
DIMENSIONAL DATA	
# of Doors	2
Net Capacity cu. ft.	11.2
Ext. Length Overall in.	51 (1294mm)
Ext. Depth Overall in.	23 ³ / ₈ (595mm)
Ext. Height Overall in.*	32 ⁵ / ₈ (830mm)
Int. Length Overall in.	45 ¹ / ₄ (1150mm)
Int. Depth Overall in.	17 ³ / ₄ (451mm)
Int. Height Overall in.	25 ⁵ / ₈ (650mm)
Net Weight lbs.	141
Gross Weight lbs.	160
# of Baskets	3
Net Capacity Gal.	84

Design and specifications subject to change without notice.
Actual shipping weight may differ due to extra packing materials for product protection.
* Height does not include 3-1/2" for caster height.

- **WARRANTY : 1 Year Parts and Labor Warranty
Additional 4 Year Warranty on Compressor**
- **No plumbing requires**
- **Self-contained system**
- **1.5" dia. casters standard**

PLAN VIEW

(unit : inch)

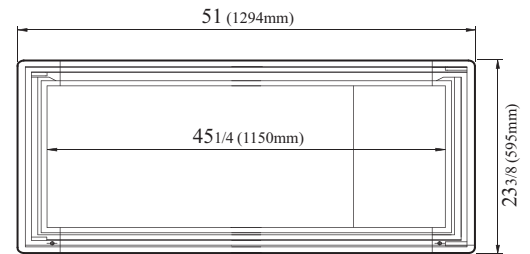

PLAN VIEW

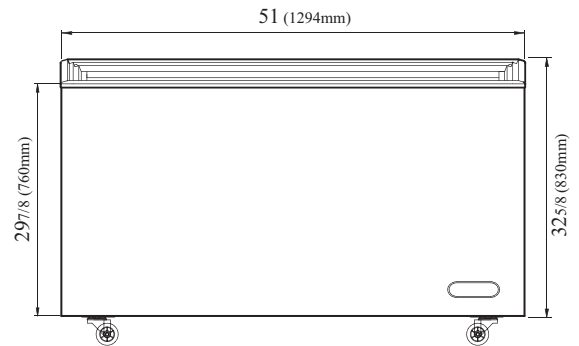

FRONT VIEW

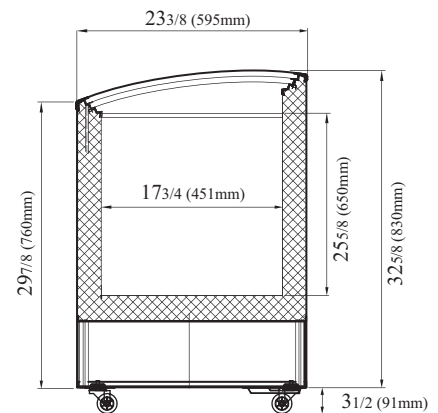

SIDE VIEW

Ver.201501



- Turbo Air : 800-627-0032
- GK : 800-500-3519
- Warranty : 800-381-7770
- AC : 888-900-1002