

Job: \_\_\_\_\_

Item: \_\_\_\_\_

Quantity: \_\_\_\_\_

## Queen Mary - Aluminum

These units are built for transporting big loads for banquets, catering, and bussing. The solid shelves have marine edges that add strength and contain spills.

- Framework is constructed of 1 3/4" x 1 3/4" x .100" wall Queen Mary Tube (tube with 3/4" radius to the outside of unit).
- Shelves are constructed of .080" sheet aluminum reinforced with 1 1/4" x 1 1/4" x .070" wall tubing.
- Base is constructed of 1 3/4" x 1 3/4" x .070" wall tubing.
- Equipped with four 8" platform type casters, two swivel and two rigid.
- Five-Year Guarantee against material defects and workmanship.
- Lifetime Guarantee against rust and corrosion.
- NSF Certified.



1455

Model No.	Size D-H-L	Weight Capacity	No. Shelves	Shelf Spacing	Ship Lbs.
1450	29" x 66" x 62"	3000 lbs.	5	12"	186
1451	29" x 66" x 75"	2500 lbs.	5	12"	210
1452	29" x 66" x 62"	2500 lbs.	4	16 1/2"	174
1455	29" x 66" x 62"	3000 lbs.	6	9 1/4"	205

Four 8" platform type casters—two swivel (#C526) two rigid (#C527).

**Each Unit Is Equipped With A Full Perimeter Bumper.**

**Options:**

"CL(E)"— see catalog for details.

**Towing Options Available — Call For Pricing**

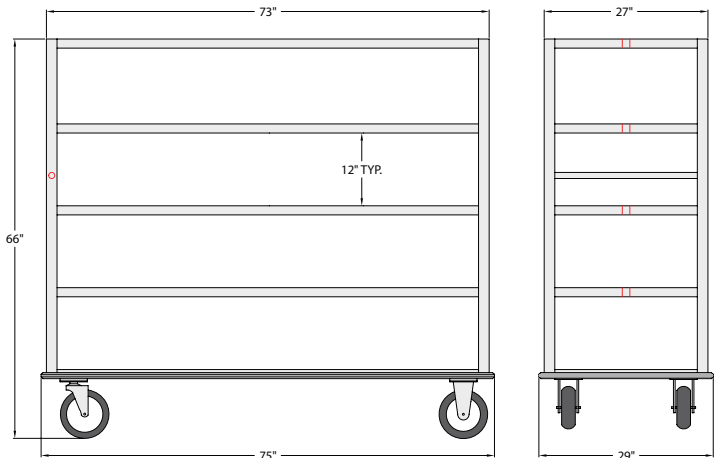

1451

*This information is for general sales and engineering use only. New Age Industrial reserves the right to modify or make changes at any time without notice to materials and specifications.*

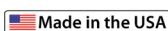

Distributed by: