

Job: _____

Item: _____

Quantity: _____

#95241 • Folding “L” Cart

This cart is designed for transporting heavy loads from the backroom to the floor. When you are done, it folds up easy storage. This cart has 7½ square feet of deck space and takes up less than 2 square feet of storage space.

- Framework is constructed out of 1½" x 1½" x .070" wall tubing.
- Handle is constructed out of 1½" diameter pipe, reinforced with ½" x 1" x .070" wall tubing.
- Equipped with four 5" platform type swivel casters and two 6"x2" platform type rigid casters.
- Lifetime Guarantee against rust and corrosion.
- Five-Year Guarantee against workmanship and material defects.

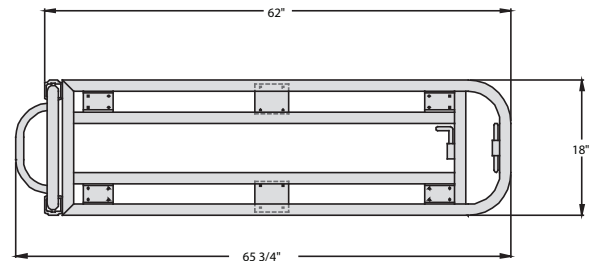

Model No.	Size W-H-L	Weight. Capacity	Deck Height	No. Of Casters	Ship Lbs.
95241	18" x 63" x 62"	1200 lbs.	9½"	6	54

Six casters - four 5" swivel (#C450) and two 2" x 6" rigid (#C518).

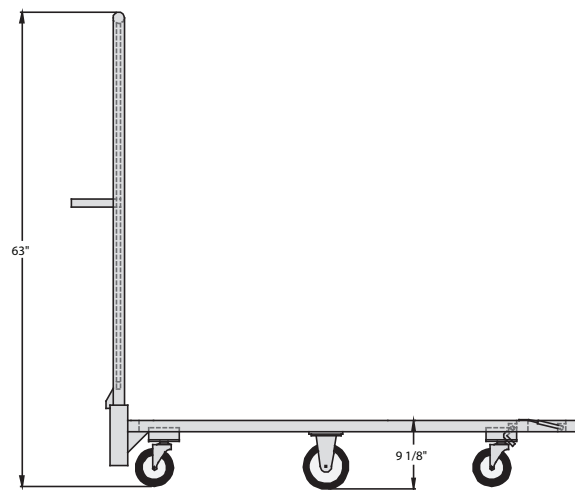

This information is for general sales and engineering use only. New Age Industrial reserves the right to modify or make changes at any time without notice to materials and specifications.

