

RackStar® 44

Project _____
 Item _____
 Quantity _____
 CSI Section 11400
 Approval _____
 Date _____

Models

RackStar 44



Standard Features

- 19-3/4" (502 mm) clearance
- WISR® Cleaning System
- Double-wall insulated doors retain heat, keeping wash water hot & generating less heat in the dish room
- Self-cleaning wash arms
- Fully automatic, including auto-fill
- Adjustable vent cowl collars
- Exclusive EnergyGuard™ controls
- Self-draining stainless steel wash pump
- Digital LED control panel
- Strike plate table limit switch
- Large front access for ease of maintenance
- Dual Rainbow Rinse™ with arched rinse arm (*patent pending*)
- Stainless steel strainer pans
- Splash shields
- Stainless steel frame and legs
- Exhaust vent fan control
- 15kW wash tank heater
- Front dress panel
- Adjustable bullet feet

Mandatory Specs

Specify:

- Electric
 Steam

Specify Voltage _____

Specify Sanitizing Method:

- High Temperature
 Chemical Sanitizing

Specify Direction of Operation:

- Left to Right
 Right to Left

Options

- Onboard Booster
 40° F (22.2° C) Rise
 70° F (38.9° C) Rise
 Single Point Connection with Onboard Booster (*3 phase only*)
 Steam Booster Heater
 23" (584 mm) Unhooded Side Loader
 30" (762 mm) Unhooded Side Loader
 1/2" Pressure Regulator
 Flanged Feet
 Prison Package

Accessories

- 36-Compartment Rack
 4-1/8" tall (104 mm)
 5 - 5/8" tall (143 mm)
 7" tall (178 mm)
 Combination Rack
 Peg Rack
 Sheet Pan Rack
 Drain Quench System
 Scaltrol
 Water Hammer Arrestor

Specifications

Uses 0.35 gallons of water (1.32 liters) per rack

Cleans 223 racks per hour

Durable stainless steel construction



Intertek



RackStar® 44

Left to Right

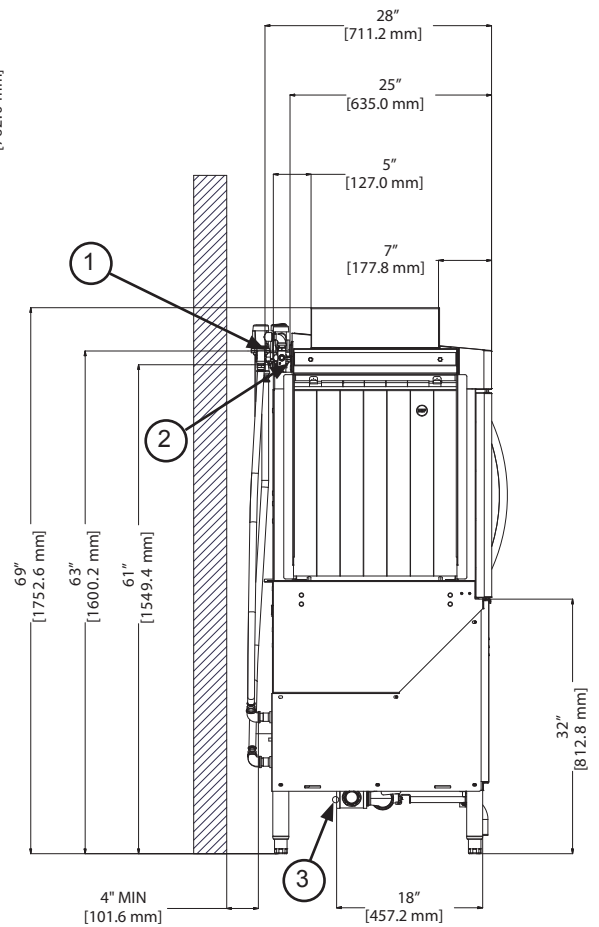
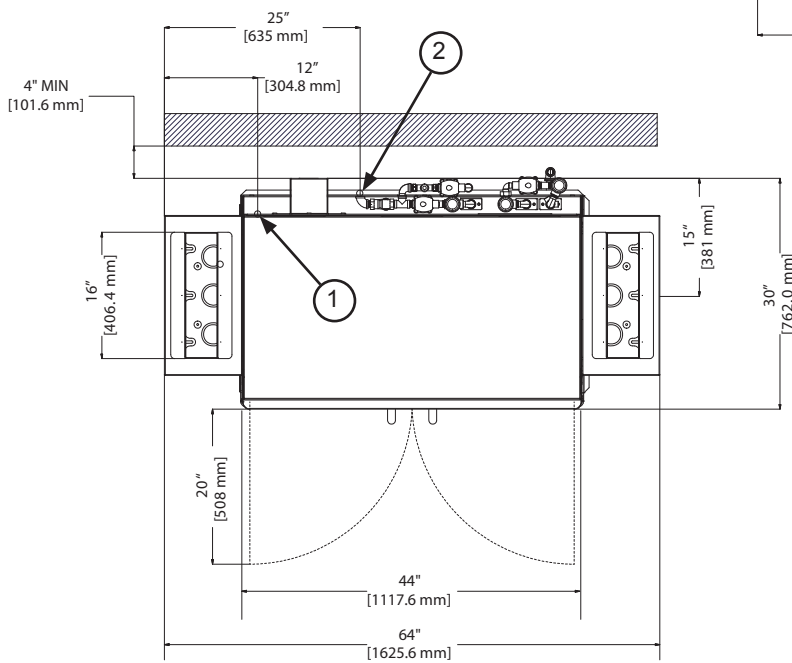
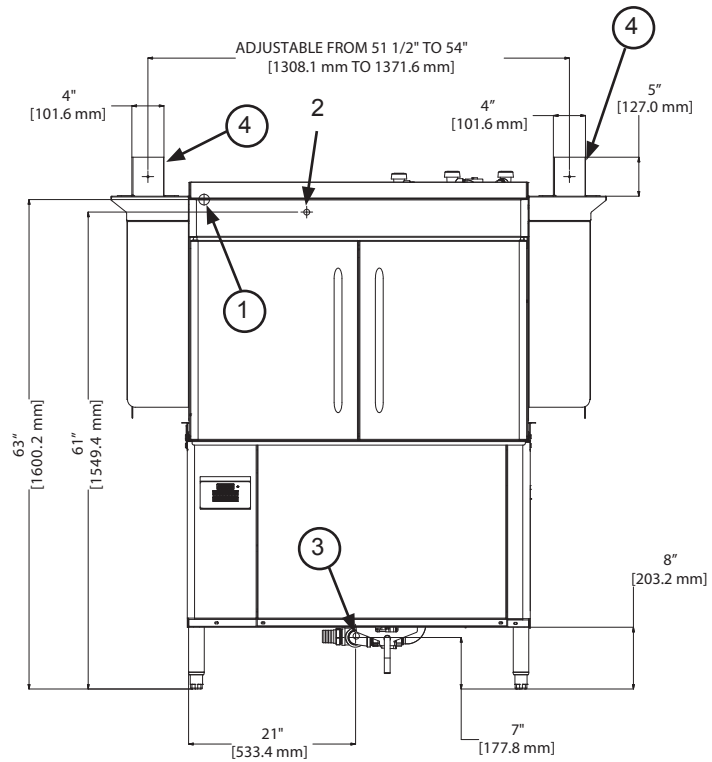

1. Electrical Connection
(Provided on both sides of unit)
2. Water Inlet
(1/2" NPT 180 °F)
3. Drain Connection
(1 1/2" NPT)
4. Vent Connections
(Including Dampers)

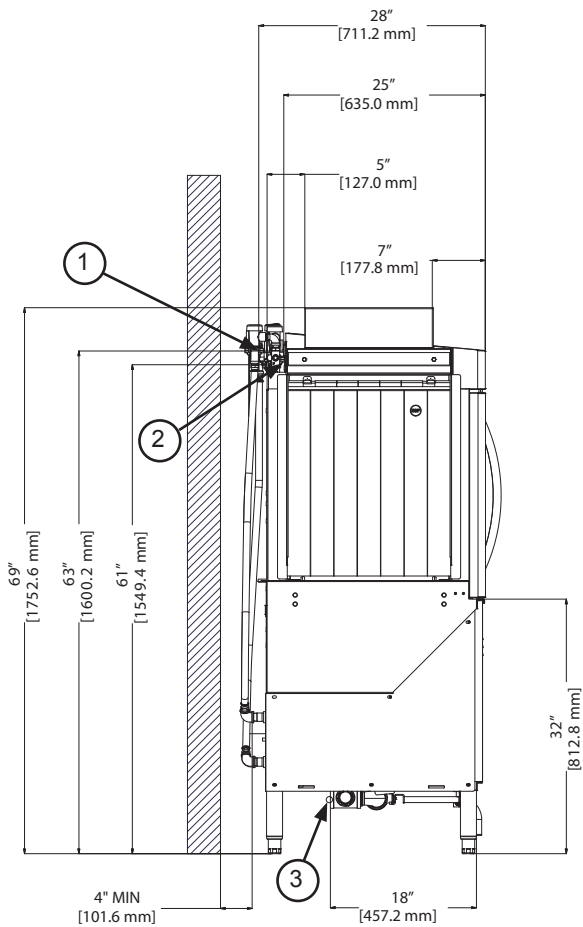
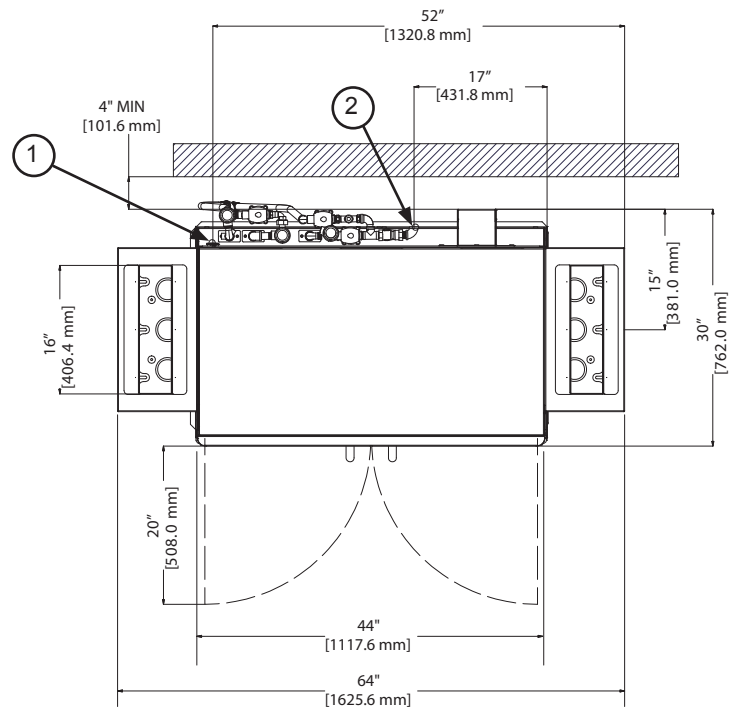
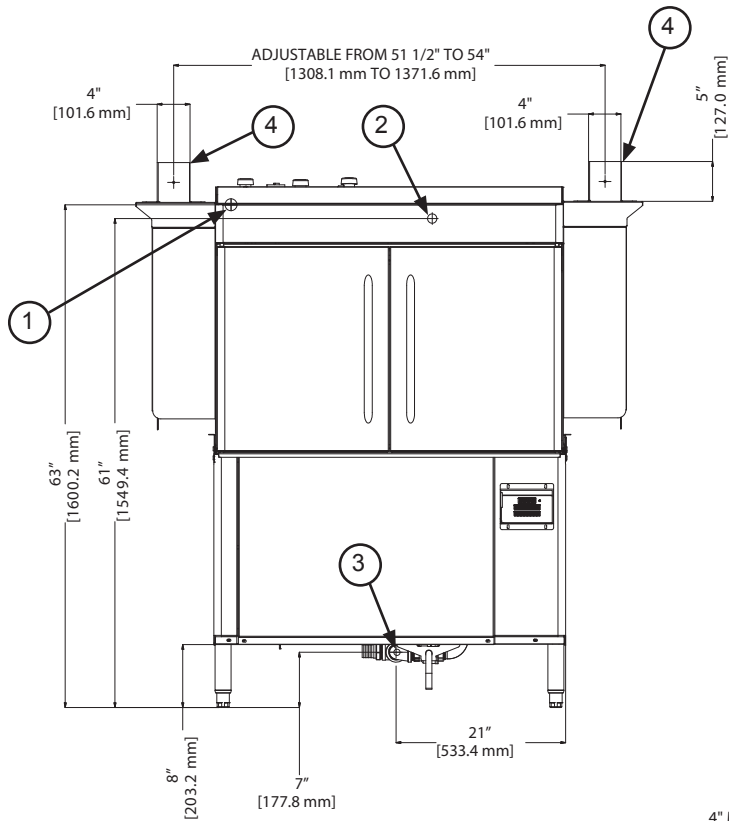

1. Electrical Connection
(Provided on both sides of unit)
2. Water Inlet
(1/2" NPT 180 °F)
3. Drain Connection
(1 1/2" NPT)
4. Vent Connections
(Including Dampers)

RECOMMENDED TABLE FABRICATION

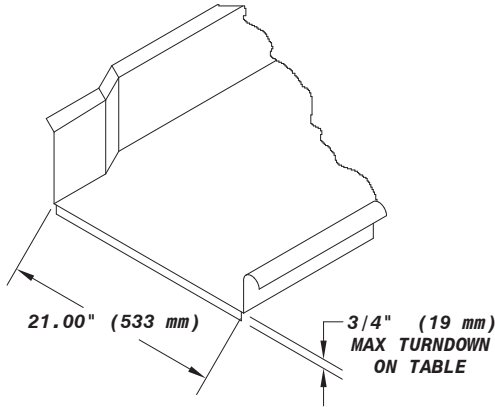
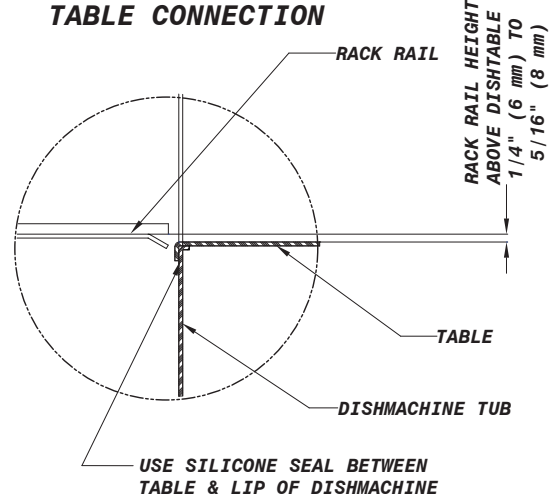

TABLE CONNECTION



MODEL NO.	MACHINE DIMENSIONS					DRAIN HEIGHT	SHIPPING INFORMATION					
	HEIGHT	LENGTH BETWEEN DISHTABLES	DEPTH	DEPTH WITH DOORS OPEN	WEIGHT		CLASS	CUBE	HEIGHT	WIDTH	DEPTH	
RackStar 44	64-1/2" (1632 mm)	44" (1118 mm)	30" (762 mm)	50" (1270 mm)	6-1/2" (165 mm)	734 lbs (333 kg)	150	163 cu. ft.	89" (2261 mm)	77" (1956 mm)	41" (1041 mm)	

OPERATING CAPACITY

	High-Temperature	Chemical Sanitizing
Racks per Hour	223	223
Dishes per Hour	5,575	5,575
Glasses per Hour	8,028	8,028

OPERATING TEMPERATURES

	High-Temperature	Chemical Sanitizing
Wash (minimum)	160° F (71° C)	120° F (49° C)
Rinse (minimum)	180° F (82° C)	120° F (49° C)

ELECTRICAL REQUIREMENTS

	Approximate Total Load AMPS	
	Electric Tank Heat	Steam
208V/60HZ/3PH	51.3	9.7
208V/60HZ/1PH	83.9	11.8
230V/60HZ/3PH	44.1	9.5
230V/60HZ/1PH	71.7	11.8
460V/60HZ/3PH	22.1	4.8

BOOSTER HEATER OPTIONS

	40° F (22.2° C) Minimum Rise		70° F (38.9° C) Minimum Rise	
	kW	AMPS	kW	AMPS
208V/60HZ/3PH	12	33.3	17.2	47.7
208V/60HZ/1PH	12	57.7	17.2	82.7
230V/60HZ/3PH	12	27.7	18	41.5
230V/60HZ/1PH	12	47.9	18	71.9
460V/60HZ/3PH	12	13.8	18	20.7

*Total amp draw for a single point connection with onboard booster heater (3 phase only) is calculated by adding the amp load for the booster heater to the amp load for the machine.

HOW TO SPECIFY: RackStar 44

WATER REQUIREMENTS

Inlet Temperature (minimum)	
With 40° F (22.2° C) Rise Booster Heater	140° F (60° C)
With 70° F (38.9° C) Rise Booster Heater	110° F (43° C)
Gallons per Hour	78 gal (295 L)
Gallons per Rack	0.35 gal (1.3 L)
Waterline Size IPS (minimum)	1/2"
Drainline Size IPS (minimum)	1-1/2"
Flow Pressure (PSI)	15
Flow Rate GPM (minimum)	1.3 (4.9 LPM)
Wash Tank Capacity	25 gal (95 L)

WASH PUMP

Wash Pump Motor	3 hp
Wash Pump Capacity	270 GPM (1022 LPM)

CONVEYOR

Conveyor Motor	1/4 hp
Conveyor Speed (feet per minute)	6.07 FPM (1.85 MPM)

VENTING REQUIREMENTS

Input End	200 CFM
Output End	200 CFM
Total CFM	400 CFM

STEAM COIL TANK HEAT (STEAM MODELS ONLY)

Steam Connection IPS	3/4"
Steam Flow Pressure (PSIG)	10-20
Consumption @ 15 PSIG (lbs/hr)	60

Jackson WWS, Inc.

Shipping Address: 6209 North U.S. Highway 25E, Gray, KY 40734

Mailing Address: P.O. Box 1060, Barbourville, KY 40906

Telephone: 888-800-5672 • Fax: 606-523-1799

Email: info@jacksonwws.com

07610-004-34-33 [10/13/16]

www.jacksonwws.com