



AX-CL06M

**Full Size Combi Oven
Manual Controls - Reversing Fans - 6 Shelves**



		Features
Manual controls	Time, temperature, steam	<ul style="list-style-type: none"> • Advanced airflow design • Automatic high speed reversing fans • Manual control: 120 minute timer or continuous ON • Interior halogen light • Includes electro valve for direct water connection • Adjustable steam percentage (0-100%) • Micro safety switch shuts oven off when door is open • Heavy duty stainless steel body construction • "Cold Door" design with double pane glass • Reinforced door hinges • Oven cavity is insulated with ultra-high temperature fiberglass insulation • 3 Stainless steel wire shelves included • Ovens can be stacked (kit required) • Hand spray for cleaning is included • Warranty: 2 year parts & 1 year labor exclusive of lights, gaskets and glass (60 days)
Load capacity	6 shelves for full size sheet pans	
High speed reversing fans	2 (3,200 rpm)	
Space between shelves	3.14" (80 mm)	
Power requirements	14,000 Watts / 208-240V/60/3 Oven supplied with power cord only / no plug	
Temperature	86° - 545° F	
Equipped with	120 minute timer Signal at end of cycle	
Cavity size (inches)	28.35 x 22.20 x 24.10 (WxDxH)	
Unit dimensions (inches)	38.60 x 33.64 x 36.35 (WxDxH)	
Shipping dimensions (inches)	41.35 x 40.55 x 39.37 (WxDxH)	
Net / Ship weight	220 lb / 263 lb	

ACCESSORIES

MODEL	AX-C6ST Stand	AX-C10ST Stand
Features	Stand suitable for CL06M-CL06D <ul style="list-style-type: none"> • Heavy duty oven stand with tray support • Slides for Full Size Ovens • Dimensions (inches): 36.22"x 24.41"x 31.50" (WxDxH) • Heavy duty stainless steel (assembly required) • Shipping dimensions (inches): 37.80"x 27.56"x 9.45" (WxDxH) • Ship Weight: 56.44 lb 	Stand suitable for CL10M-CL10D <ul style="list-style-type: none"> • Heavy duty oven stand with tray support • slides for Full Size Ovens • Dimensions (inches): 36.22"x 24.41"x 27.56" (WxDxH) • Heavy duty stainless steel (assembly required) • Shipping dimensions (inches) 37.80"x 26"x 9.45" (WxDxH) • Ship Weight: 54.24 lb

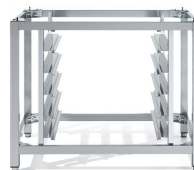
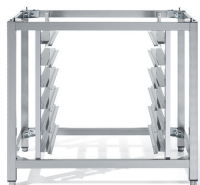

MODEL	STACKING KIT	CASTERS
Features	<ul style="list-style-type: none"> • Stacking kit for "COMBI" Series 	<ul style="list-style-type: none"> • Shipping dimensions 4 wheels: 11.82"x 11.82"x 4.73" / 4.41 lb



HEAVY DUTY
DEGREASER RTU



COMBI OVEN CLEANER



FILTER

LINE DRAWINGS

AX-CL06M

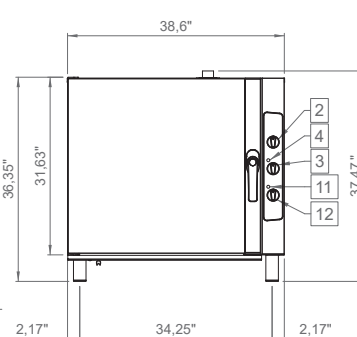
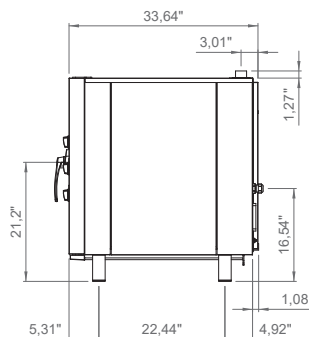
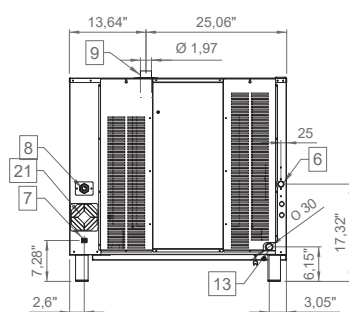

AX-CL06D

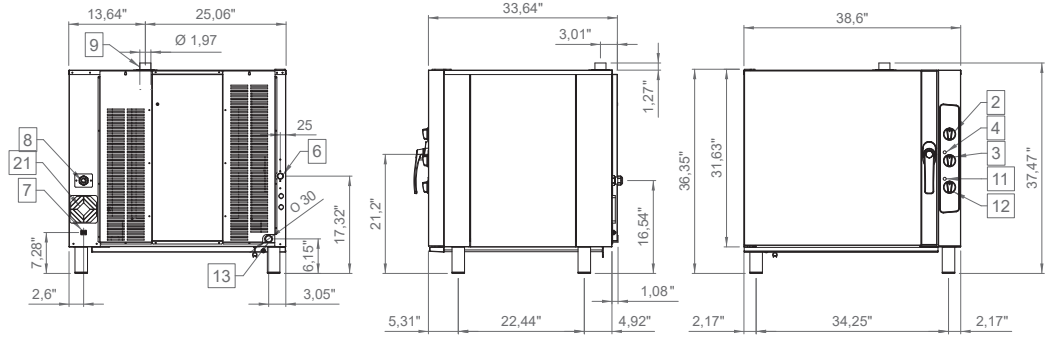

AX-CL10M

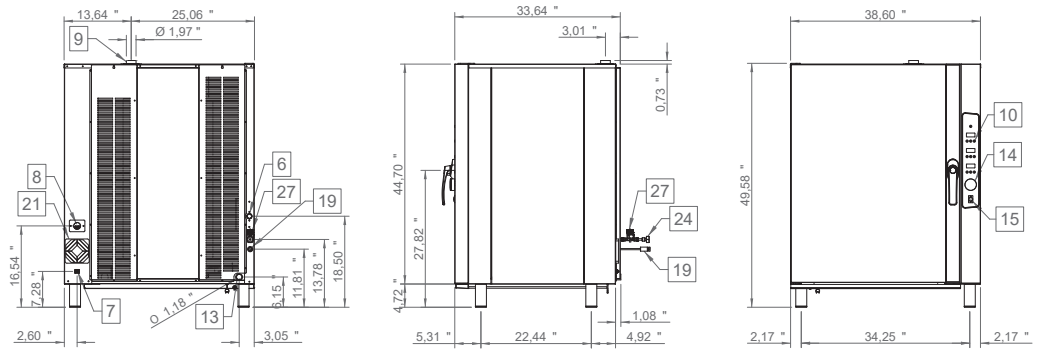

AX-CL10D

