



# AX-CL10D

**Full Size Combi Oven  
Digital Controls - Reversing Fans - 10 Shelves**



<b>Digital controls</b>	Time, temperature, steam, 4 cooking cycles for each program, automatic pre-heating	<b>Features</b>
<b>Load capacity</b>	10 shelves for full size sheet pans	
<b>High speed reversing fans</b>	3 (3,200 rpm)	<ul style="list-style-type: none"> <li>• Advanced airflow design</li> <li>• Automatic reversing fans - 2 speeds</li> <li>• Digital programmable controls / 99 programs / automatic pre-heating / 4 cooking cycles for each program</li> <li>• Interior halogen light</li> <li>• Includes electro valve for direct water connection</li> <li>• Core food probe included / Delta T Cooking</li> <li>• Adjustable steam percentage (0-100%)</li> <li>• Adjustable exhaust flue</li> <li>• Heavy duty stainless steel body construction</li> <li>• "Cold Door" design with double pane glass</li> <li>• Reinforced door hinges</li> <li>• Oven cavity is insulated with ultra-high temperature fiberglass insulation</li> <li>• 4 Stainless steel wire shelves included</li> <li>• Micro safety switch shuts oven off when door is open</li> <li>• Ovens can be stacked (kit required)</li> <li>• Self-cleaning cycle</li> <li>• Warranty: 2 year parts &amp; 1 year labor exclusive of lights, gaskets and glass (60 days)</li> </ul>
<b>Space between shelves</b>	3.14" (80 mm)	
<b>Power requirements</b>	20,000 Watts / 208-240V/60/3 Oven supplied with power cord only / no plug	
<b>Temperature</b>	86° - 500° F	
<b>Equipped with</b>	16 hour timer Signal at end of cycle	
<b>Cavity size (inches)</b>	28.35 x 22.20 x 37.32 (WxDxH)	
<b>Unit dimensions (inches)</b>	38.60 x 33.64 x 49.58 (WxDxH)	
<b>Shipping dimensions (inches)</b>	41.35 x 40.55 x 52.37 (WxDxH)	
<b>Net / Ship weight</b>	313 lb / 353 lb	

# ACCESSORIES

MODEL	AX-C6ST Stand	AX-C10ST Stand
<b>Features</b>	Stand suitable for CL06M-CL06D <ul style="list-style-type: none"> <li>• Heavy duty oven stand with tray support</li> <li>• Slides for Full Size Ovens</li> <li>• Dimensions (inches): 36.22"x 24.41"x 31.50" (WxDxH)</li> <li>• Heavy duty stainless steel (assembly required)</li> <li>• Shipping dimensions (inches): 37.80"x 27.56"x 9.45" (WxDxH)</li> <li>• Ship Weight: 56.44 lb</li> </ul>	Stand suitable for CL10M-CL10D <ul style="list-style-type: none"> <li>• Heavy duty oven stand with tray support</li> <li>• slides for Full Size Ovens</li> <li>• Dimensions (inches): 36.22"x 24.41"x 27.56" (WxDxH)</li> <li>• Heavy duty stainless steel (assembly required)</li> <li>• Shipping dimensions (inches) 37.80"x 26"x 9.45" (WxDxH)</li> <li>• Ship Weight: 54.24 lb</li> </ul>

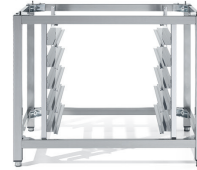
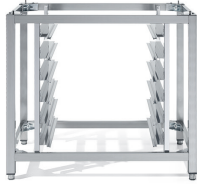

MODEL	STACKING KIT	CASTERS
<b>Features</b>	<ul style="list-style-type: none"> <li>• Stacking kit for "COMBI" Series</li> </ul>	<ul style="list-style-type: none"> <li>• Shipping dimensions 4 wheels: 11.82"x 11.82"x 4.73" / 4.41 lb</li> </ul>



HEAVY DUTY  
DEGREASER RTU



COMBI OVEN CLEANER



FILTER

# LINE DRAWINGS

## AX-CL06M

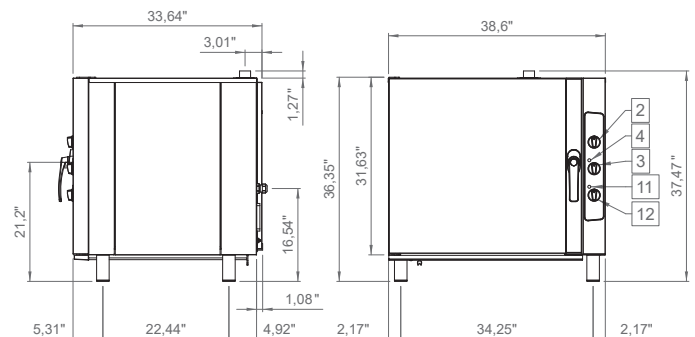
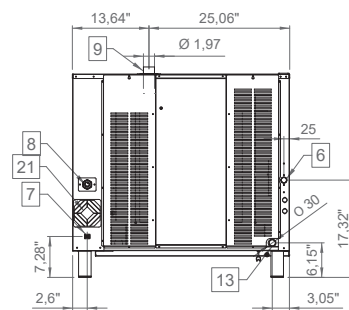

# AX-CL06D

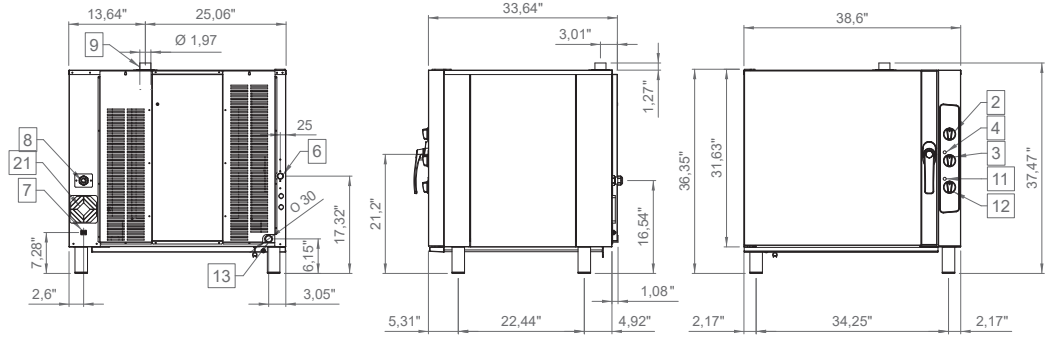

# AX-CL10M

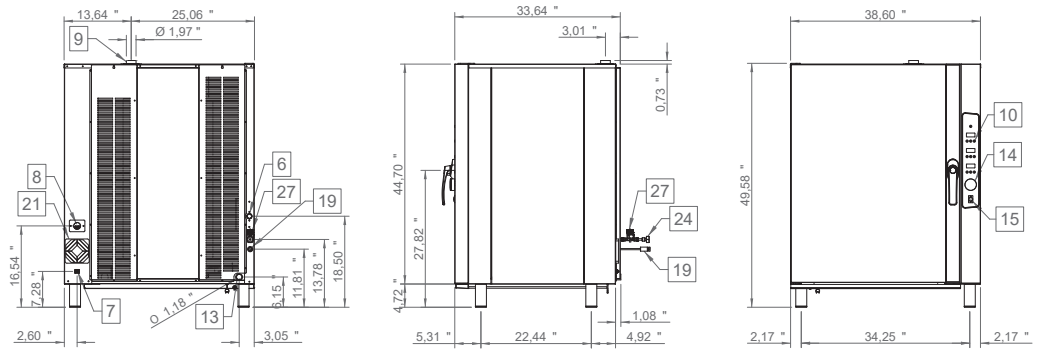

# AX-CL10D

