



BEVERAGE-AIR

Project: _____

AIA#

Item: _____

Location: _____

SIS#

Approved: _____

BF COUNTERCHILL

BF051AG Blast Chiller/Freezer

**MODEL:
BF051AG**



BF051AG

**3 Year Parts/Labor Warranty
Additional 2 Year Compressor Warranty**

CABINET CONSTRUCTION

- Stainless steel top, side and door exterior
- Stainless steel interior
- Electronic control display
- Control and command circuit board, 99 user programmable custom parameters
- Timed manual defrost device
- Cabinet features a core temperature probe to insert in the food to measure the blast chilling and freezing temperature
- Ergonomic handles and magnetic gasket
- Stainless steel, height adjustable 2" adjustable legs.
- High storage capacity compartments, with rounded edges to make cleaning easy
- Self-closing doors with stay-open feature at 100°
- Cabinet will accommodate 5 pans (13" x 21") (pans not included)
- Stainless steel wire rack structure, which provides excellent air circulation, minimizing the time required to blast chill the food
- Oven to Chiller capable
- 2" Adjustable legs

OPTIONAL ACCESSORIES

- 3.2" Casters with brake
- Remote units available
- UVC kit (sterilizing lamp)
- Printing kit

REFRIGERATION SYSTEM

- Refrigeration system uses R404A for compliance with environmental safety standards
- Evaporator with high ventilation ensures that the cooling system works with unbeatable efficiency
- Automatic condensation evaporation system that does not require power and manual defrost device

BF051AG COUNTER CHILL: Blast Chiller / Freezer



3779 Champion Blvd., Winston-Salem, NC 27105
1-888-845-9800 Fax: 1-336-245-6453
Beverage-Air.com sales@bevair.com



BEVERAGE-AIR

Counterchill - Blast Chiller

Models: BF051AG

MODEL	BF051AG
EXTERNAL DIMENSIONAL DATA	
Width Overall	31.1"
Depth Overall	27.6"
Height Overall on Legs	33.46"
INTERNAL DIMENSIONAL DATA	
Internal Width (in)	26.4"
Internal Depth (in)	15"
Internal Height	14.96"
Chilling Cycle 90 Minute Chilling Cycle	194°F / 37°F
Chilling Capacity (lbs)	40 lbs
Freezing Cycle 240 Minute Freezing Cycle	194°F / 0.4°F
Freezing Capacity (lbs)	26 lbs
Number of Pans (pans not included)	5
Pan Size (in)	13" x 21" x 2"
Distance Between Adjustable Tray Slides (in)	2 35/64"
ELECTRICAL DATA	
Electric Power Supply	208-240/1/60
Input Electric	1400W
Max Absorbed Current	6.6
WEIGHT DATA	
Gross Weight (Crated lbs)	240 lbs
Height - Crated	43"
Width - Crated	35"
Depth - Crated	32"

E ELECTRICAL CONNECTION

W DRAIN CONNECTION

Model Views

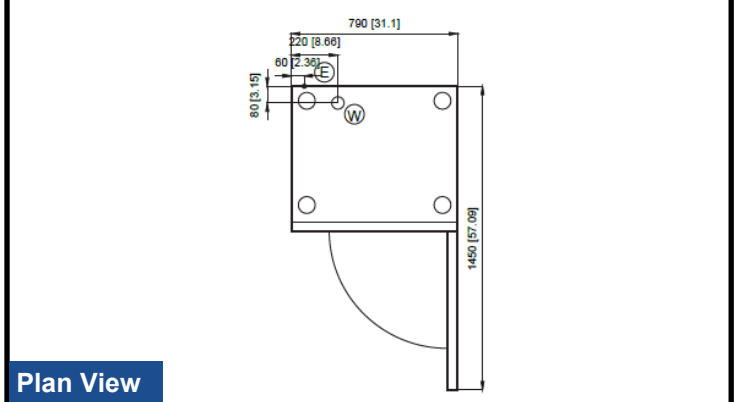

Plan View

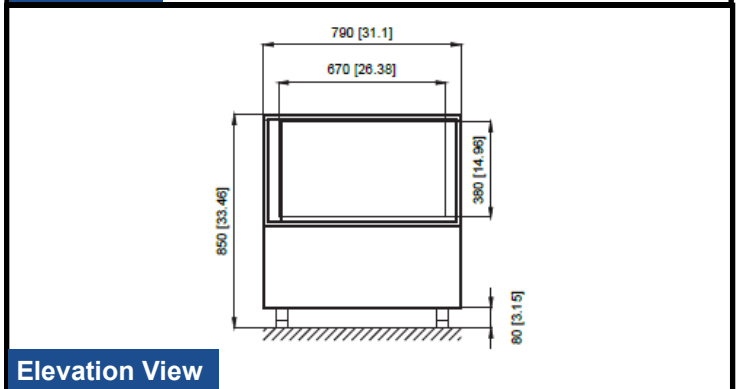

Elevation View

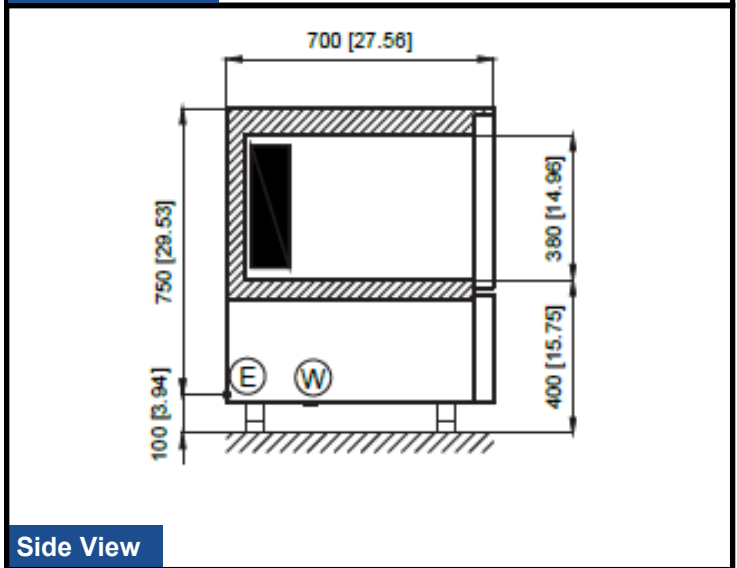

Side View

ELECTRICAL CONNECTION



Units pre-wired at factory and include cord and plug set.

NEMA 6-15P



an Ali Group Company



The Spirit of Excellence

3779 Champion Blvd., Winston-Salem, NC 27105
1-888-845-9800 Fax: 1-336-245-6453
Beverage-Air.com sales@bevair.com