



# BEVERAGE-AIR

Project: \_\_\_\_\_

AIA#

Item: \_\_\_\_\_

Location: \_\_\_\_\_

SIS#

Approved: \_\_\_\_\_

## DPD FOOD PREPERATION SERIES

### DPD67 Deli/Pizza Prep Table with Four Drawers

**MODELS:**  
**DPD67-4**



**DPD67-4**

**3 Year Parts/Labor Warranty**  
**Additional 2 Year Compressor Warranty**

### CABINET CONSTRUCTION

- Stainless steel front, sides, top, drawers, and grille (*galvanized back & bottom*)
- Interior liner is made of corrosion resistant aluminum
- Aluminum interior liner prevents spill for falling into cabinet
- Stainless steel top
- Removable hoods & and insulated lid assemblies are made of matching stainless steel
- Full electronic control
- Drawers are self-closing on cartridge style hinges
- Magnetic gaskets provide positive seal on drawers
- 3" Casters, 2 with brakes standard
- 19" Wide reversible cutting board is removable for easy cleaning
- Units will accept pans up to 6" deep (pans are not included)
- Drawer frames are heavy duty stainless steel
- Telescoping slides, with locking mechanism to prevent drawers from being pulled off of cabinet
- Heavy duty pan dividers supports are standard
- Locking divider bars
- Raised rail maintains temperatures between 36° - 38°F

### OPTIONS & ACCESSORIES

- Door models available
- Locks
- Bun tray rack
- Self dividers
- Lift off lid
- 6" Casters
- 6" Legs Black or Seismic / Flanged
- Food pedal door opener

### REFRIGERATION SYSTEM

- Refrigeration system uses R134a refrigerant to comply with all environmental concerns
- Automatic, non-electric evaporator
- Epoxy coated evaporator coil

DPD67 Food Preparation Series: Deli/Pizza Prep Series



3779 Champion Blvd., Winston-Salem, NC 27105  
1-888-845-9800 Fax: 1-336-245-6453  
Beverage-Air.com sales@bevair.com



# BEVERAGE-AIR

MODEL	DPD67-4
<b>EXTERNAL DIMENSIONAL DATA</b>	
Width Overall	67"
Depth Overall with Handle & Cutting Board	38 3/8"
Height Overall with 3" Casters	55 1/2"
Number of Drawers	4
Depth with Drawers Extended	57 1/2"
Drawers Opening (in)	21 5/8" x 10 3/8" 21 5/8" x 10 1/4"
Depth, Cutting Board	19"
<b>INTERNAL DIMENSIONAL DATA</b>	
NET Capacity (cubic ft.)	27
Internal Width Useable (in)	48"
Internal Depth Overall (in)	26"
Internal Height Overall (in)	25"
<b>ELECTRICAL DATA</b>	
Full Load Amperes 115/60/1	6.3
<b>REFRIGERATION DATA</b>	
Horsepower	1/4
<b>WEIGHT DATA</b>	
Gross Weight (Crated lbs)	410 lbs
Height - Crated	47 19/50"
Width - Crated	70"
Depth - Crated	39 19/50"

## Deli/Pizza Preparation Table

Models: DPD67-4

### Model Views

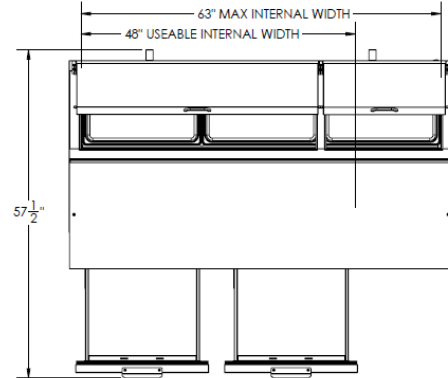

### Plan View

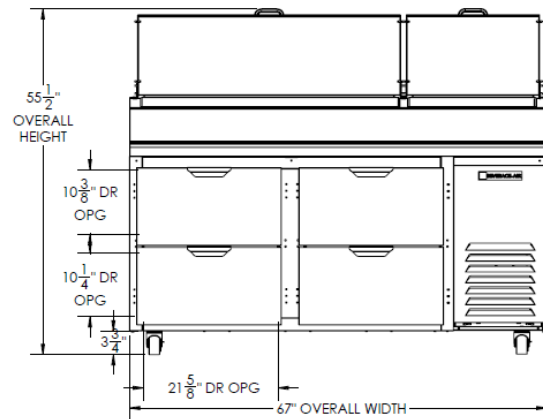

### Elevation View

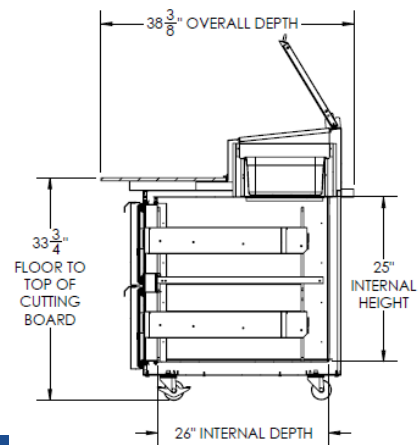

### Side View

### ELECTRICAL CONNECTION



115/60/1  
NEMA-5-15P

Units pre-wired at factory and include 8' long cord and plug set.



an Ali Group Company



The Spirit of Excellence

3779 Champion Blvd., Winston-Salem, NC 27105  
1-888-845-9800 Fax: 1-336-245-6453  
Beverage-Air.com sales@bevair.com