



BEVERAGE-AIR

Project: _____

AIA#

Item: _____

Location: _____

SIS#

Approved: _____

P-SERIES TOP MOUNTED PASS-THRU REFRIGERATORS

MODELS:
PRD2-1BHG

PRD2-1BHG Half Glass Pass-Thru Double Doors



PRD2-1BHG

3 Year Parts/Labor Warranty
Additional 2 Year Compressor Warranty

CABINET CONSTRUCTION

- Stainless steel exterior
- Interior liner is made of corrosion resistant aluminum
- Full electronic control
- LED lighting standard
- Expansion Valve technology
- Self-closing doors on cam-lift hinges, with 120° hold open feature
- One piece snap-in magnetic door gasket for positive seal
- Stainless steel breakers
- Adjustable 6" legs standard
- Anti-Microbial door handles
- Three (3) heavy-duty epoxy coated shelves per section
- Refrigeration system maintains product temperatures of 36 - 38°F

OPTIONS & ACCESSORIES

- Stainless steel interior
- Stainless steel shelves
- Tray slid kit #1 angle, stainless steel, includes (13) sets of hotel pan slides & standard pilasters, (1 kit accommodates 1/2 section)
- Tray slide pair, 1 tray slide set for (1) 18" x 26" or (2) 14" x 18" pans (A)
- Stainless steel universal tray slide pair, 1 tray slide set for (1) 18" x 26" or (2) 14" x 18" pans (AC)
- Epoxy coated wire rod tray slide (Kit #4)
- Epoxy shelves
- Shelf clips
- Stainless steel breaker
- 6" Legs
- 3" Casters
- Remote option

REFRIGERATION SYSTEM

- Refrigeration system uses R134A
- Automatic, non-eclectic defrost
- Epoxy coated evaporator coil

PRD2-1BHG Top Mount Models: P Series



3779 Champion Blvd., Winston-Salem, NC 27105
1-888-845-9800 Fax: 1-336-245-6453
Beverage-Air.com sales@bevair.com



BEVERAGE-AIR

P Series - Top Mount Refrigerators

Models: PRD2-1BHG

MODEL	PRD2-1BHG
EXTERNAL DIMENSIONAL DATA	
Width Overall	52 1/8"
Depth Overall with Handle	36 1/2"
Height Overall	83 3/4"
Number of Doors	8
Depth with Door Open 90°	82 1/2"
Door Opening (in)	21 1/2" x 25 1/4"
INTERNAL DIMENSIONAL DATA	
NET Capacity (cubic ft.)	48
Internal Width Overall (in)	48 1/8"
Internal Depth Overall (in)	26"
Internal Height Overall (in)	56 5/8"
Number of Shelves	6
ELECTRICAL DATA	
Full Load Amperes 115/60/1	12.8
REFRIGERATION DATA	
Horsepower	1/3
Capacity (BTU/Hr)*	2360
WEIGHT DATA	
Gross Weight (Crated lbs)	817 lbs
Height - Crated	87"
Width - Crated	60"
Depth - Crated	45"

Model Views

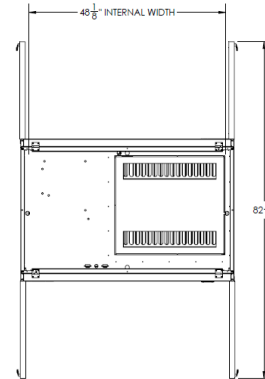

Plan View

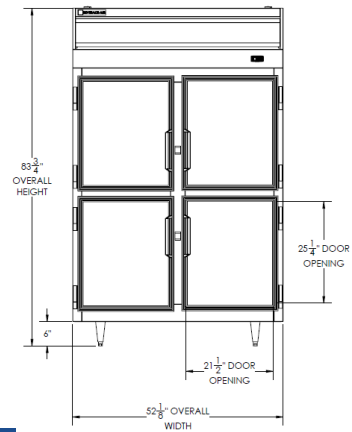

Elevation View

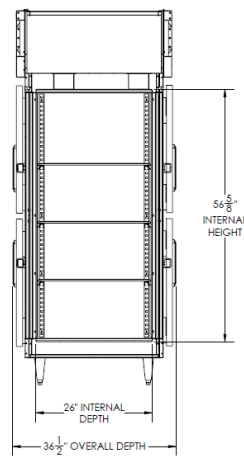

Side View

ELECTRICAL CONNECTION



115/60/1
NEMA 5-20P

Units pre-wired at factory and include 8' long cord and plug set.



an Ali Group Company



The Spirit of Excellence

3779 Champion Blvd., Winston-Salem, NC 27105
1-888-845-9800 Fax: 1-336-245-6453
Beverage-Air.com sales@bevair.com