



# BEVERAGE-AIR

Project: \_\_\_\_\_

AIA#

Item: \_\_\_\_\_

Location: \_\_\_\_\_

SIS#

Approved: \_\_\_\_\_

## WTR WORKTOP REFRIGERATOR

WTR67AHC Worktop Refrigerator  
Hydrocarbon Series

MODELS:  
WTR67AHC

WTR67AHC Worktop Refrigerator: Worktop Series

**3 Year Parts/Labor Warranty**  
**Additional 2 Year Compressor Warranty**

### CABINET CONSTRUCTION



WTR67AHC

- Stainless steel front, sides and doors, (*galvanized back & bottom*)
- Interior liner is made of corrosion resistant aluminum
- Stainless steel top
- 4" Built-in backsplash
- Full electronic control
- Interior thermometer is standard
- Self-closing doors with 120° stay-open feature, on cam-lift hinges
- Easy door removal for service and cleaning
- Magnetic gasket attached to each door for positive seal
- Painted aluminum door handles
- 6" Casters, two (2) with brakes standard
- Two epoxy-coated steel wire shelves per section standard
- Field reversible doors
- Maintains product temperature between 36°F and 38°F

### OPTIONS & ACCESSORIES

- Stainless steel back and grille
- Stainless steel interior
- Right or left hinged door
- Locks (solid doors only)
- Bun rack
- Wire shelf divider
- Cutting board
- 3" Casters or 6" legs
- Low profile casters
- Remote option

### REFRIGERATION SYSTEM

- Refrigeration system uses R290 refrigerant to comply with all environmental concerns
- Automatic, non-electric defrost
- Epoxy coated evaporator coil



3779 Champion Blvd., Winston-Salem, NC 27105  
1-888-845-9800 Fax: 1-336-245-6453  
Beverage-Air.com sales@bevair.com



# BEVERAGE-AIR

## Worktop Refrigerator

MODEL	WTR67AHC
<b>EXTERNAL DIMENSIONAL DATA</b>	
Width Overall	67"
Depth Overall with Countertop	34"
Height Overall with 6" Casters	39 1/2"
Number of Doors	2
Depth with Door Open 90 °	55 1/8"
Door Opening (in)	21 5/8" X 23 5/8"
<b>INTERNAL DIMENSIONAL DATA</b>	
NET Capacity (cubic ft.)	18.97
Internal Width Overall (in)	48"
Internal Depth Overall (in)	26"
Internal Height Overall (in)	25"
Number of Shelves	4
<b>ELECTRICAL DATA</b>	
Full Load Amperes 115/60/1	3.0
<b>REFRIGERATION DATA</b>	
Horsepower	1/5
Capacity (BTU/Hr)*	1350
<b>WEIGHT DATA</b>	
Gross Weight	400 lbs
Height - Crated	46 1/2"
Width - Crated	70"
Depth - Crated	37"

### Model Views

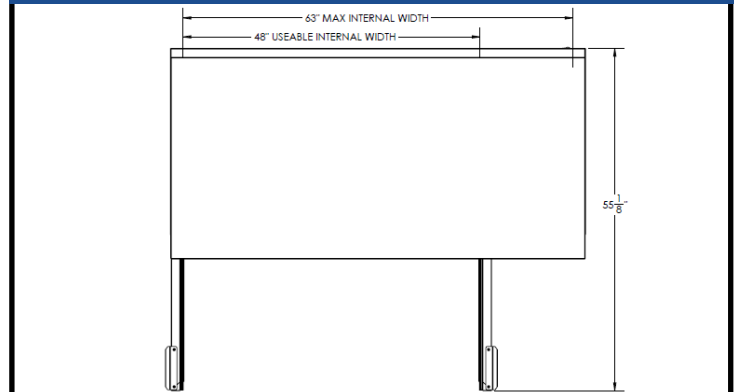

Plan View

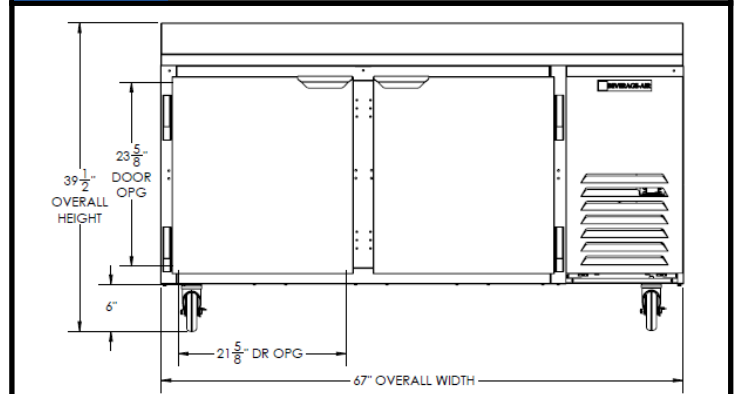

Elevation View

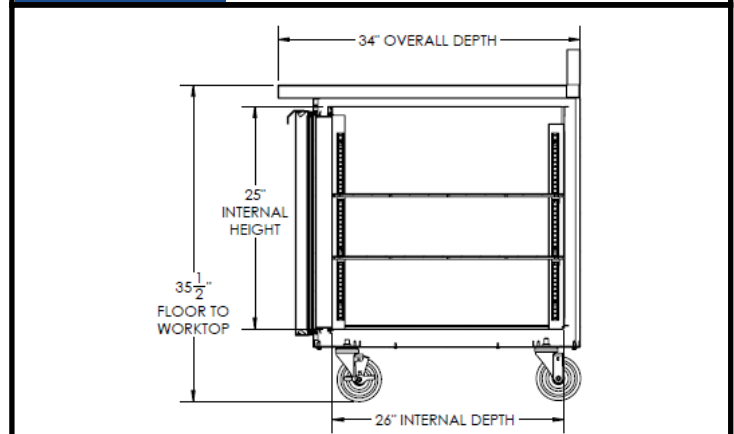

Side View

### ELECTRICAL CONNECTION



115/60/1  
NEMA-5-15P

Units pre-wired at factory and include 8' long cord and plug set.



an Ali Group Company



The Spirit of Excellence

3779 Champion Blvd., Winston-Salem, NC 27105  
1-888-845-9800 Fax: 1-336-245-6453  
Beverage-Air.com sales@bevair.com