

# Room Service & Late Tray Carts

## Stainless Steel

Models 5500, 5510



Model 5500



Model 5510

Shown with optional Top rails

### Compact Design For Room Service And Late Tray Meal Trays

#### Benefits

- Accommodate 14" x 18" or 15" x 20" size trays
- Designed for smaller, more frequent meal deliveries

#### Features

- Cart body and removable stainless steel ledge panels are easily cleaned and sanitized
- Compartment floor drain facilitates interior cleaning
- Base corner bumpers protect walls, furnishings and doors
- Paddle latch door catch assures positive door closure and convenient one-hand operation.

#### Casters

- Heavy-duty 6" diameter with 2" wide rounded cushion-tread for quiet, easy movement on hard or carpeted floors

#### Specifications:

Unit shall be of stainless steel welded and riveted construction to accommodate 14" x 18" or 15" x 20" trays. Material thickness shall be of 16 gauge for top and floor/base, 20 gauge for sides and back. Door shall be of 20 gauge insulated double-pan design, and shall be mounted to unit frame with two each 3" (76 mm) heavy-duty stainless steel hinges. Hinges shall be welded to door and unit frame. Door shall swing 270° to provide full access to tray compartment, and shall be easily removable by lifting off of hinges. Door latch shall be recessed paddle design. Tray ledges shall be 18 gauge stainless steel angle, welded to an 18 gauge stainless steel frame panel at 6" (152 mm) spacing. Ledge panels shall accommodate both 14" x 18" or 15" x 20" trays, and shall be removable for easy cleaning. Tray compartment shall have vents on end panels and shall have perforated center floor drains. Unit base shall have 1¼" (32 mm) thick extruded PVC rounded bumpers mounted to corners. Unit shall have four each extra-load plate type casters, two fixed and two swivel, mounted to a 14 gauge stainless steel dolly on unit base. Swivel casters shall have shielded ball bearing races and zerk fittings for lubrication of bearings. Caster wheels shall be 6" (152 mm) diameter with 2" wide, non-marking, rounded cushion tread. Unit shall be NSF listed.

#### Model 5510 Specifications:

Ledge clearance between compartment floor and bottom set of legs shall be 8¼".

#### Model 5500 Specifications:

Shall have welded 1" tubular push handle.

Spec. # \_\_\_\_\_

AIA # \_\_\_\_\_

Lakeside Manufacturing, Inc.

4900 West Electric Avenue • West Milwaukee, WI 53219 U.S.A.

800-558-8565 • 414-902-6400 • Fax 414-902-6446 • info@eLakeside.com • www.eLakesideFoodservice.com

# Room Service & Late Tray Carts

## Stainless Steel

### Models

5500

5510

Model 5500

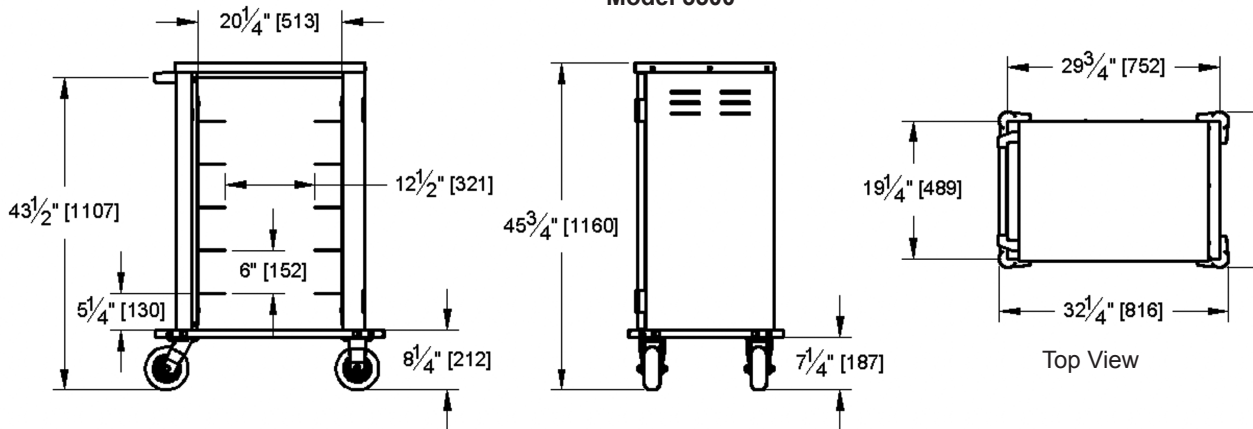

Model 5510

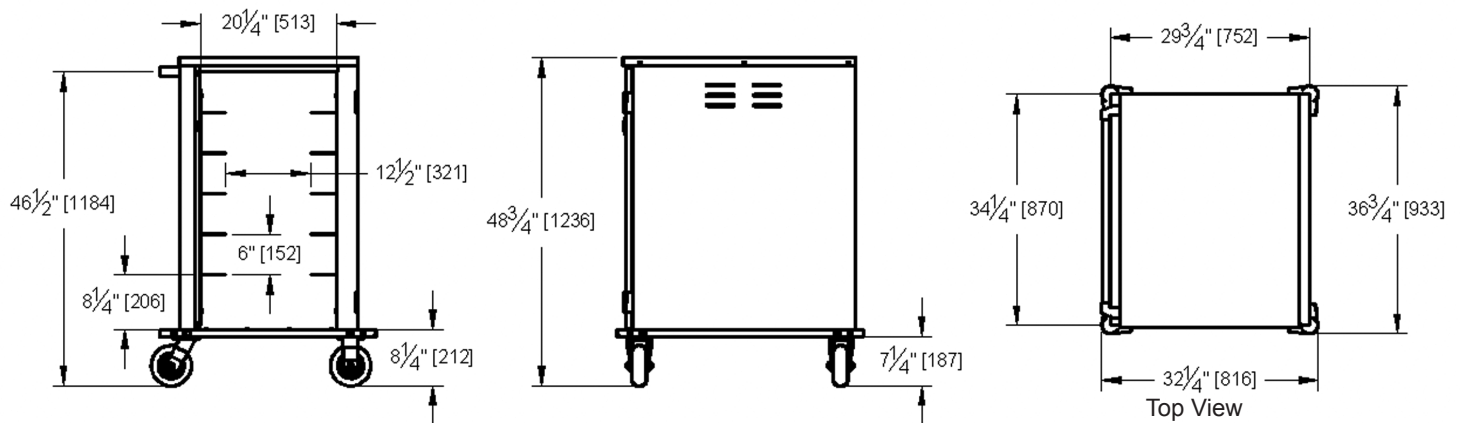

### Product Information:

Model	Overall Size			Accommodates Tray Size	Tray Capacity	Casters		Case Wt. Lbs.
	W	L	H			Type	Dia.	
5500	32 1/4" (819)	21 3/4" (522)	45 3/4" (1162)	14" x 18" or 15" x 20" (356 x 457 or 381 x 508)	6 Ea.	2 Ea. Swivel 2 Ea. Fixed	6" (152)	190 (86.4 kg)
5510	32 1/4" (819)	36 3/4" (933)	48 3/4" (1238)	14" x 18" or 15" x 20" (356 x 457 or 381 x 508)	12 Ea.	2 Ea. Swivel 2 Ea. Fixed	6" (152)	225 (101.4 kg)

Dimensions in ( ) denote metric millimeters, unless otherwise noted.

### Options:

- Full-perimeter bumper
- 2" high top rail
- Custom ledge spacing



Removable Ledge Panels



Interior Floor Drain

**L LAKESIDE**  
MOVING FOODSERVICE FORWARD™

Lakeside Manufacturing, Inc.  
4900 West Electric Avenue • West Milwaukee, WI 53219 U.S.A.  
800-558-8565 • 414-902-6400 • Fax 414-902-6446  
info@eLakeside.com • www.eLakesideFooservice.com

Spec. #

AIA #