

ITEM # _____

MODEL # _____

PROJECT NAME # _____

SIS # _____

AIA # _____

K45 Vertical Cutter-Mixer



K45 Vertical Cutter-Mixer

PNC 603359 (K452V-02) K45 (2-speed)
208 V/3p/60Hz – 3.8A

PNC 603362 (K45VV-02) K45 (variable speed)
120 V/1p/60Hz – 5.0A

Short Form Specification

Item No. _____

Unit to be Electrolux K452V-02 K45 Vertical Cutter-Mixer. Electrical characteristics to be 208 V, Three-phase operation with 2-speed at 1800 or 3500 rpm. The Electrolux K452VV-02 K45 Vertical Cutter-Mixer. Electrical characteristics to be 120 V, Single-phase operation with variable speeds from 300 – 3300 rpm. Vertical Cutter-Mixer designed for vertical cutting and mixing in 4.7 quart quantities: puree, mix, chop, blend, mix and knead dough. A compact design for operator convenience the K45 occupies minimal counter space. Housing constructed of Stainless steel with rubber feet on base.

Main features

- Power: 1-1/4HP for Two-speed Model and 1-1/3HP for Variable Speed Model
- 1800/3500 RPM for Two-speed Model and 300 – 3300 RPM for Variable Speed Model.
- 900 Watts for Two-speed Model and 1 kW for Variable Speed Model.
- Red OFF, Green ON, and PULSE Buttons
- Compact Design
- Belt Drive
- All Stainless Steel Bowl
- Magnetic safety system and motor brake. Prevents machine from running when bowl lid swings away from magnetic switch or is open.

Delivered with :

- 4.7 Qt. Stainless Steel bowl with microtooth edge “S” blade included.
- Complete selection of accessories available.
- Dimensions: (HxLxW): 18.5” x 16.3” x 10”
- Approx. shipping weight—49 lbs
- NEMA L15-20P for Two-speed Model and NEMA 6-20P for Variable Speed Model.
- 2 year parts warranty, 1 year labor.

Included Accessories:

- Microtooth Blade Rotor - 4.7 Qt. VCM PNC 653580
- Lid + Bowl Scraper for 4.7 Qt. VCM PNC 653588
- 4.7 Qt. Stainless Bowl PNC 653589

Optional Accessories:

- Smooth Blade Rotor - 4.7 Qt. VCM PNC 653579
- Microtooth Blade Rotor - 4.7 Qt. VCM PNC 653580
- Lid + Bowl Scraper for 4.7 Qt. VCM PNC 653588
- 4.7 Qt. Stainless Bowl PNC 653589
- Smooth blade rotor (new S shape) for 4.7qt bowl PNC 653614



With
L15-20P
(for Model
PNC 603359)



With
6-20P
(for Model
PNC 603362)

Approval: _____

Electrolux Professional, Inc.

www.electroluxusa.com/professional

10200 David Taylor Drive, Charlotte, NC 28262 • Telephone Number: 866-449-4200 • Fax Number: 704-547-7401

KaTom Restaurant Supply, Inc.

Front View

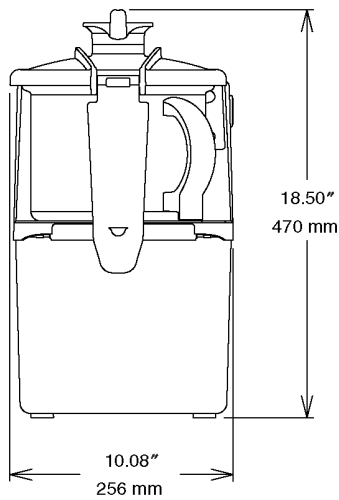

Side View

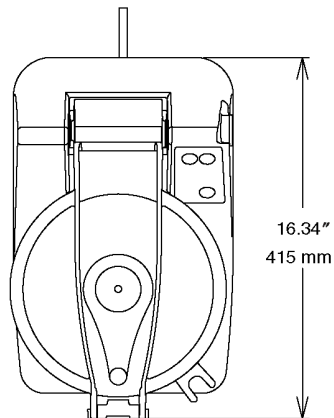

EC = Electrical connection

Top View

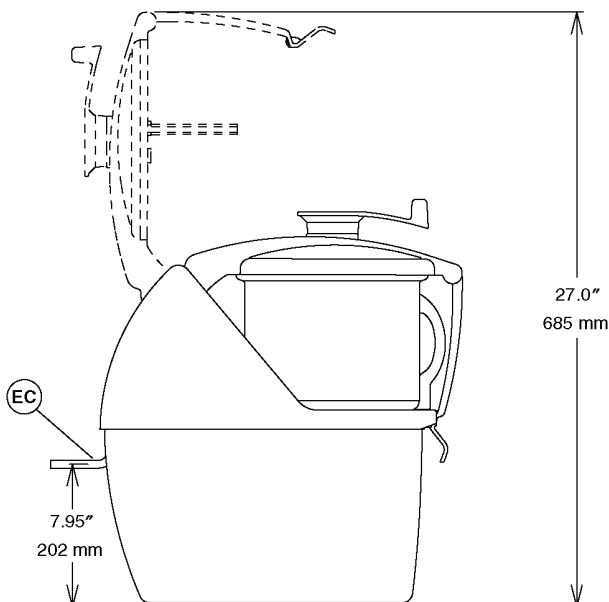

Electric

Supply voltage:

603359 (K452V-02) 208 V/3p/60Hz – 3.8A

603362 (K45VV-02) 120 V/1p/60Hz – 5.0A

Key Information

Uses of Food Processor

MEAT

Rough mincing

Pates

Small sausages

Large sausages

Minced meat

Shellfish

Fine mincing

Stuffing

Mousses

PASTRY

Shortcrust

Cold water paste

Flan

POWDER

Almonds

Hazelnuts

FRUITS AND VEGETABLES

Purees

Mousses

Syrups

CHOPPING

Parsley

Onions

K45 Vertical Cutter-Mixer

The company reserves the right to make modifications to the products without prior notice. All information correct at time of printing.

11-19-12