

AR-7E

ELECTRIC ROTISSERIE



AR-7E SHOWN WITH DOUBLE PANE,
CURVED GLASS DOORS AND OPTIONAL
NON-CONTROL SIDE PASS-THROUGH DOOR

• Operating at only 8.3 kilowatts, the Alto-Shaam rotisserie with EcoSmart® technology uses very little electricity to cook a full load of delicious food.

- Temperature-dropping hold mode further saves on energy costs.
- Solid stainless steel back prevents further heat loss.
- Cook and hold in a single, counter-top rotisserie that features a combination of convection and radiant heat.
- A choice of one or two cooking stages for an improved finished product.
- Solid state electronic control has a clear, easy-to-read LED display to cook by time and features an automatic temperature reduction to a holding mode where product can remain until needed.
- Programmable control option with a seven program memory for both the cooking and holding function.
- The rotisserie can be stacked with an identical rotisserie oven or with a matching holding cabinet.
- Interior drip strips channel drippings into a bottom drip pan for convenient removal.
- Spits, rotating disks, drip strips are also removable for easy cleaning.
- Interior lighting is recessed to protect from breakage.

The Alto-Shaam electric rotisserie is constructed of a heavy gauge, non-magnetic stainless steel with a sealed cooking chamber for heat retention. Low-e glass on front includes a handle with magnetic door latch. Spit rotation is controlled by one (1) 1/2 hp motorized disk that provides an incremental rotation jog and automatic stop when door is opened. The cook temperature range is from 250° to 425°F (121° to 218°C). Additional electronic control features include temperature display in Fahrenheit or Celsius; a product hold key with a temperature range of 140° to 210°F (60° to 99°C), cooking set-points from 1 minute to 4 hours; and emergency stop. The rotisserie has a stainless steel exterior finish and is furnished with 4-inch adjustable legs, 7 angled spits and a drip pan with drain.

- MODEL AR-7E:** Electric Rotisserie Oven, Single pane, flat door, solid back
- MODEL AR-7E:** Electric Rotisserie Oven, Double pane, curved glass, solid back

FACTORY INSTALLED OPTIONS



ANSI/NSF 4



- Deluxe programmable control lets the operator set up to seven cooking programs for both cooking and holding functions.
- Panel Color Choices
 - ➔ Specify color choice:
 - Stainless Steel, standard
 - Black, optional
 - Burgundy, optional
 - Custom Color, optional

ADDITIONAL FEATURES

- Multipurpose wire basket option handles irregular size products, denser items, or heavier products that require additional support.

- Reach-in compartment is standard.
 - ➔ Specify pass-through design as a special order.
 - Single pane, flat glass door
 - Double pane, curved glass door
- Right-hand door swing is standard
 - Specify left-hand door as a special order

- Optional handle on non-control side for pass-through use.
- Stackable options available.

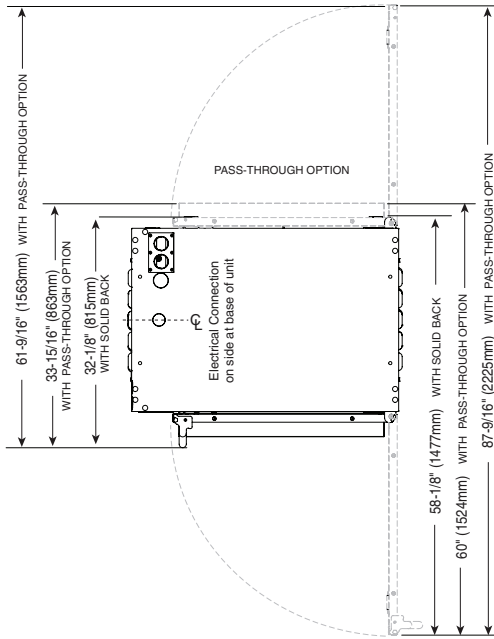

AR-7E WITH FLAT DOOR

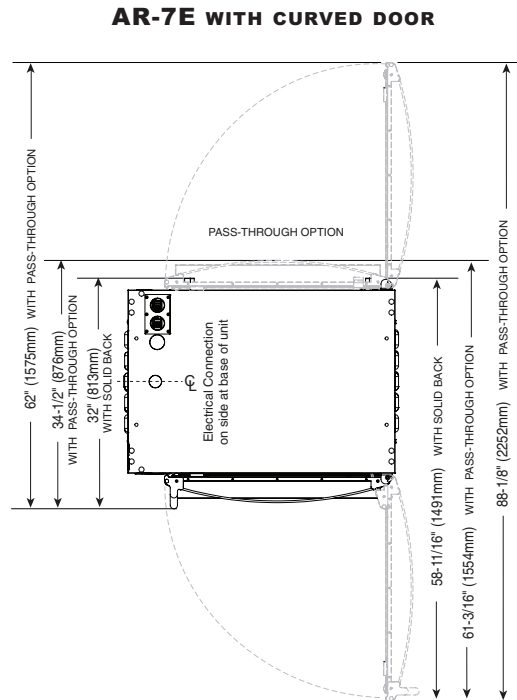

AR-7E WITH CURVED DOOR

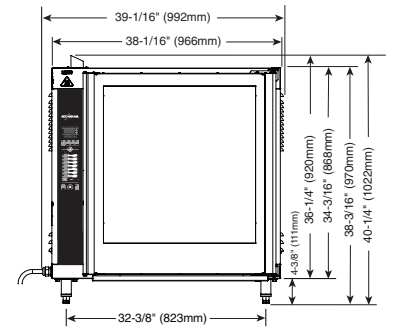

FRONT VIEW

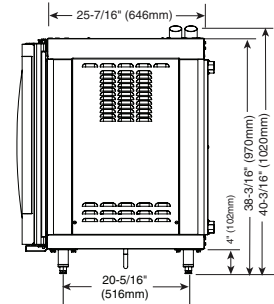

SIDE VIEW

NOTE — HEIGHT DIMENSION VARIANCE:

- 2" (51mm) rubber feet add 2-1/8" (54mm) CE ONLY (FOR COUNTER TOP UNITS ONLY)
- 4" (102mm) legs add 4-3/8" (111mm)
- 5" (127mm) casters add 6-3/8" (162mm)
- 6" (152mm) legs add 6-3/8" (162mm)

INSTALLATION REQUIREMENTS

- Oven must be installed level.
- Exhaust ventilation is required
- Install on a non-combustible surface only
- The oven must not be installed in any area where it may be affected by steam, grease, dripping water, high temperatures, or any other severely adverse conditions.
- In order to maintain NSF standards, counter models must be sealed at the bottom by an NSF approved sealant or equipped with 4" (102mm) legs.
- **Power Cord Connection:** The side connection is recommended for all applications. If bottom connection is necessary for counter top units, user will need to provide a cutout in the countertop to allow the cord to hang freely without crimping.

CLEARANCE REQUIREMENTS

6" (152mm) left, right, and rear sides

WEIGHT

NET: 361 lb (164 kg) SHIP: 451 lb (205 kg)

CRATE DIMENSIONS: (L x W x H)

53" x 45" x 49" (1346mm x 1143mm x 1243mm)

DIMENSIONS: H x W x D

SINGLE PANE, FLAT GLASS

EXTERIOR: 40-1/4" x 39-1/16 x 32-1/8" (1022mm x 992mm x 815mm)	PASS-THROUGH EXTERIOR (OPTION): 40-1/4" x 39-1/16" x 33-15/16" (1022mm x 992mm x 863mm)
---	--

DOUBLE PANE, CURVED GLASS

EXTERIOR: 40-1/4" x 39-1/16 x 32" (1022mm x 992mm x 813mm)	PASS-THROUGH EXTERIOR (OPTION): 40-1/4" x 39-1/16" x 34-1/2" (1022mm x 992mm x 876mm)
---	--

ELECTRICAL

VOLTAGE	PHASE	CYCLE/HZ	AMPS	kW	
208 (AGCY)	1	60	40.0	8.3	BARE END NO PLUG
240 (AGCY)	1	60	38.0	8.8	
208 (AGCY)	3	60	33.0/ph	8.3	BARE END NO PLUG
240 (AGCY)	3	60	32.0/ph	8.8	
380-415 (AGCY)	3	50	24.0/ph	8.8	
380	3	50	22.0/ph	7.4	NO CORD NO PLUG
415	3	50	24.0/ph	8.8	

PRODUCT CAPACITY

98 lb (44 kg) MAXIMUM

ANGLED SPITS (STANDARD):

- Up to twenty-one (21) 3-1/2 lb chickens (1,6 kg)
- Up to twenty-eight (28) 2-1/2 to 3 lb chickens (1,1 to 1,4 kg)

PIERCING SPITS (OPTIONAL):

- Up to twenty-eight (28) 2-1/2 to 3-1/2 lb chickens (1,1 to 1,6 kg)

TURKEY SPIT (OPTIONAL):

- One (1) Turkey up to 25 lb (11 kg)

ELECTRIC ROTISSERIE **AR-7E**

STANDARD ACCESSORIES

- Seven (7) removable stainless steel angled spits
- One (1) removable stainless steel drip pan with drain, 2" (51mm) deep
- Two (2) removable stainless steel angled drip strips
- Six (6) 20 watt recessed bulbs

OPTIONS & ACCESSORIES

<table style="width: 100%; border-collapse: collapse;"> <tr> <td style="width: 80%;"><input type="checkbox"/> CASTERS, 5" (127mm)</td> <td style="width: 20%; text-align: right;">4007</td> </tr> <tr> <td colspan="2" style="font-size: small;">NOT AVAILABLE WITH VENTLESS HOOD STACKED UNITS</td> </tr> <tr> <td><input type="checkbox"/> DOOR HANDLE, NON-CONTROL SIDE</td> <td style="text-align: right;">HD-26900</td> </tr> <tr> <td><input type="checkbox"/> DRIP PAN, STAINLESS STEEL (WITHOUT DRAIN)</td> <td style="text-align: right;">1001976</td> </tr> <tr> <td><input type="checkbox"/> FEET, RUBBER, 2" (51mm) CE ONLY</td> <td style="text-align: right;">5001614</td> </tr> <tr> <td colspan="2" style="font-size: small;">FOR COUNTER TOP UNITS ONLY</td> </tr> <tr> <td colspan="2">LEGS</td> </tr> <tr> <td><input type="checkbox"/> 6" (152mm) ASSEMBLY</td> <td style="text-align: right;">5001414</td> </tr> <tr> <td><input type="checkbox"/> 6" (152mm) ASSEMBLY, FLANGED FEET</td> <td style="text-align: right;">5001761</td> </tr> <tr> <td colspan="2" style="font-size: small;">REQUIRED FOR STACKING UNITS.</td> </tr> <tr> <td><input type="checkbox"/> MULTI-PURPOSE WIRE BASKET (.50 dia. pin) BS-26019</td> <td></td> </tr> <tr> <td colspan="2">SPITS</td> </tr> <tr> <td><input type="checkbox"/> ANGLED SPIT, STAINLESS STEEL</td> <td style="text-align: right;">SI-25934</td> </tr> <tr> <td><input type="checkbox"/> PIERCING SPIT, STAINLESS STEEL</td> <td style="text-align: right;">SI-25729</td> </tr> <tr> <td><input type="checkbox"/> TURKEY SPIT, STAINLESS STEEL</td> <td style="text-align: right;">5011681</td> </tr> <tr> <td><input type="checkbox"/> ANGLED SPIT, TEFLON COATED</td> <td style="text-align: right;">5001335</td> </tr> </table>	<input type="checkbox"/> CASTERS, 5" (127mm)	4007	NOT AVAILABLE WITH VENTLESS HOOD STACKED UNITS		<input type="checkbox"/> DOOR HANDLE, NON-CONTROL SIDE	HD-26900	<input type="checkbox"/> DRIP PAN, STAINLESS STEEL (WITHOUT DRAIN)	1001976	<input type="checkbox"/> FEET, RUBBER, 2" (51mm) CE ONLY	5001614	FOR COUNTER TOP UNITS ONLY		LEGS		<input type="checkbox"/> 6" (152mm) ASSEMBLY	5001414	<input type="checkbox"/> 6" (152mm) ASSEMBLY, FLANGED FEET	5001761	REQUIRED FOR STACKING UNITS.		<input type="checkbox"/> MULTI-PURPOSE WIRE BASKET (.50 dia. pin) BS-26019		SPITS		<input type="checkbox"/> ANGLED SPIT, STAINLESS STEEL	SI-25934	<input type="checkbox"/> PIERCING SPIT, STAINLESS STEEL	SI-25729	<input type="checkbox"/> TURKEY SPIT, STAINLESS STEEL	5011681	<input type="checkbox"/> ANGLED SPIT, TEFLON COATED	5001335	<table style="width: 100%; border-collapse: collapse;"> <tr> <td colspan="2">STACKING ASSEMBLY (FACTORY INSTALLED)</td> </tr> <tr> <td colspan="2">AR-7E OVER AR-7E (RIGHT-HAND)</td> </tr> <tr> <td><input type="checkbox"/> (208-240V, 1PH)</td> <td style="text-align: right;">5009981</td> </tr> <tr> <td><input type="checkbox"/> (208-240V, 3PH)</td> <td style="text-align: right;">5009982</td> </tr> <tr> <td><input type="checkbox"/> (380-415V)</td> <td style="text-align: right;">5009983</td> </tr> <tr> <td colspan="2">AR-7E OVER AR-7E (LEFT-HAND)</td> </tr> <tr> <td><input type="checkbox"/> (208-240V, 1PH)</td> <td style="text-align: right;">5010355</td> </tr> <tr> <td><input type="checkbox"/> (208-240V, 3PH)</td> <td style="text-align: right;">5010356</td> </tr> <tr> <td><input type="checkbox"/> (380-415V)</td> <td style="text-align: right;">5010357</td> </tr> <tr> <td colspan="2">AR-7E OVER AR-7H</td> </tr> <tr> <td><input type="checkbox"/> (208-240V, 1PH)</td> <td style="text-align: right;">5008787</td> </tr> <tr> <td><input type="checkbox"/> (208-240V, 3PH)</td> <td style="text-align: right;">5008948</td> </tr> <tr> <td><input type="checkbox"/> (380-415V)</td> <td style="text-align: right;">5008922</td> </tr> <tr> <td colspan="2">STAND, STAINLESS STEEL</td> </tr> <tr> <td><input type="checkbox"/> WITH STORAGE SHELF</td> <td style="text-align: right;">FR-26550</td> </tr> <tr> <td><input type="checkbox"/> OPEN (AR-7E OVER 750-S)</td> <td style="text-align: right;">5002058</td> </tr> <tr> <td colspan="2">TEFLON® COATED ACCESSORIES - COMMERCIAL GRADE</td> </tr> <tr> <td><input type="checkbox"/> INCLUDES DISKS, DRIP TRAY AND 7 ANGLED SPITS</td> <td style="text-align: right;">5001302</td> </tr> </table>	STACKING ASSEMBLY (FACTORY INSTALLED)		AR-7E OVER AR-7E (RIGHT-HAND)		<input type="checkbox"/> (208-240V, 1PH)	5009981	<input type="checkbox"/> (208-240V, 3PH)	5009982	<input type="checkbox"/> (380-415V)	5009983	AR-7E OVER AR-7E (LEFT-HAND)		<input type="checkbox"/> (208-240V, 1PH)	5010355	<input type="checkbox"/> (208-240V, 3PH)	5010356	<input type="checkbox"/> (380-415V)	5010357	AR-7E OVER AR-7H		<input type="checkbox"/> (208-240V, 1PH)	5008787	<input type="checkbox"/> (208-240V, 3PH)	5008948	<input type="checkbox"/> (380-415V)	5008922	STAND, STAINLESS STEEL		<input type="checkbox"/> WITH STORAGE SHELF	FR-26550	<input type="checkbox"/> OPEN (AR-7E OVER 750-S)	5002058	TEFLON® COATED ACCESSORIES - COMMERCIAL GRADE		<input type="checkbox"/> INCLUDES DISKS, DRIP TRAY AND 7 ANGLED SPITS	5001302
<input type="checkbox"/> CASTERS, 5" (127mm)	4007																																																																				
NOT AVAILABLE WITH VENTLESS HOOD STACKED UNITS																																																																					
<input type="checkbox"/> DOOR HANDLE, NON-CONTROL SIDE	HD-26900																																																																				
<input type="checkbox"/> DRIP PAN, STAINLESS STEEL (WITHOUT DRAIN)	1001976																																																																				
<input type="checkbox"/> FEET, RUBBER, 2" (51mm) CE ONLY	5001614																																																																				
FOR COUNTER TOP UNITS ONLY																																																																					
LEGS																																																																					
<input type="checkbox"/> 6" (152mm) ASSEMBLY	5001414																																																																				
<input type="checkbox"/> 6" (152mm) ASSEMBLY, FLANGED FEET	5001761																																																																				
REQUIRED FOR STACKING UNITS.																																																																					
<input type="checkbox"/> MULTI-PURPOSE WIRE BASKET (.50 dia. pin) BS-26019																																																																					
SPITS																																																																					
<input type="checkbox"/> ANGLED SPIT, STAINLESS STEEL	SI-25934																																																																				
<input type="checkbox"/> PIERCING SPIT, STAINLESS STEEL	SI-25729																																																																				
<input type="checkbox"/> TURKEY SPIT, STAINLESS STEEL	5011681																																																																				
<input type="checkbox"/> ANGLED SPIT, TEFLON COATED	5001335																																																																				
STACKING ASSEMBLY (FACTORY INSTALLED)																																																																					
AR-7E OVER AR-7E (RIGHT-HAND)																																																																					
<input type="checkbox"/> (208-240V, 1PH)	5009981																																																																				
<input type="checkbox"/> (208-240V, 3PH)	5009982																																																																				
<input type="checkbox"/> (380-415V)	5009983																																																																				
AR-7E OVER AR-7E (LEFT-HAND)																																																																					
<input type="checkbox"/> (208-240V, 1PH)	5010355																																																																				
<input type="checkbox"/> (208-240V, 3PH)	5010356																																																																				
<input type="checkbox"/> (380-415V)	5010357																																																																				
AR-7E OVER AR-7H																																																																					
<input type="checkbox"/> (208-240V, 1PH)	5008787																																																																				
<input type="checkbox"/> (208-240V, 3PH)	5008948																																																																				
<input type="checkbox"/> (380-415V)	5008922																																																																				
STAND, STAINLESS STEEL																																																																					
<input type="checkbox"/> WITH STORAGE SHELF	FR-26550																																																																				
<input type="checkbox"/> OPEN (AR-7E OVER 750-S)	5002058																																																																				
TEFLON® COATED ACCESSORIES - COMMERCIAL GRADE																																																																					
<input type="checkbox"/> INCLUDES DISKS, DRIP TRAY AND 7 ANGLED SPITS	5001302																																																																				



STACKING COMBINATION

AR-7EVH ROTISSERIE OVER
AR-7H COMPANION HOLDING CABINET

STACKING COMBINATIONS (FACTORY INSTALLED)

AR-7E rotisserie *over* AR-7E rotisserie

Requires 6" (152mm) leg assembly **5001414** or 5" (127mm) casters **4007** and stacking assembly **5006291** for applications within the United States. Applications outside the U.S. requires 6" (152mm) legs with flanged feet **5001761** bolted to the floor.

[OVERALL HEIGHT: 76-7/8" (1953 mm)]

AR-7E rotisserie *over* AR-7H companion holding cabinet

Requires 6" (152mm) leg assembly **5001414** or 5" (127mm) casters **4007** and stacking assembly (**5008787**, **5008948** or **5008922** - depending on voltage - see list above) for applications within the United States. Applications outside the U.S. requires 6" (152mm) legs with flanged feet **5001761** bolted to the floor.

[OVERALL HEIGHT: 76-7/8" (1953 mm)]

AR-7EVH rotisserie *over* AR-7H companion holding cabinet

Requires 6" (152mm) legs with flanged feet **5001761** bolted to the floor.

[OVERALL HEIGHT: 90-13/16" (2307 mm)]



W164 N9221 Water Street • P.O. Box 450 • Menomonee Falls, Wisconsin 53052-0450 • U.S.A.

PHONE: 262.251.3800 800.558.8744 U.S.A./CANADA FAX: 262.251.7067 800.329.8744 U.S.A. ONLY

www.alto-shaam.com



AR-7EVH

ROTISSERIE WITH VENTLESS HOOD



LISTED
COOKING APPLIANCE
WITH INTEGRAL SYSTEMS
FOR LIMITING THE EMISSION
OF GREASE LADEN AIR
TPCS

ALSO CLASSIFIED BY
UNDERWRITERS
LABORATORIES INC.®
IN ACCORDANCE WITH
NSF4 - 2002

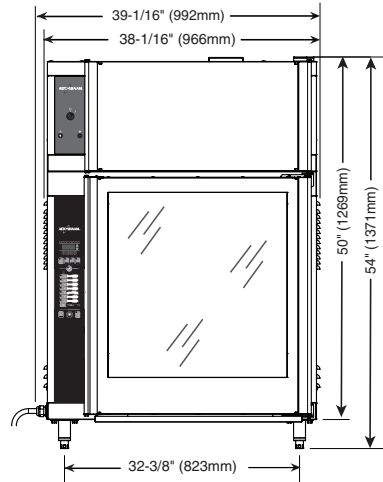
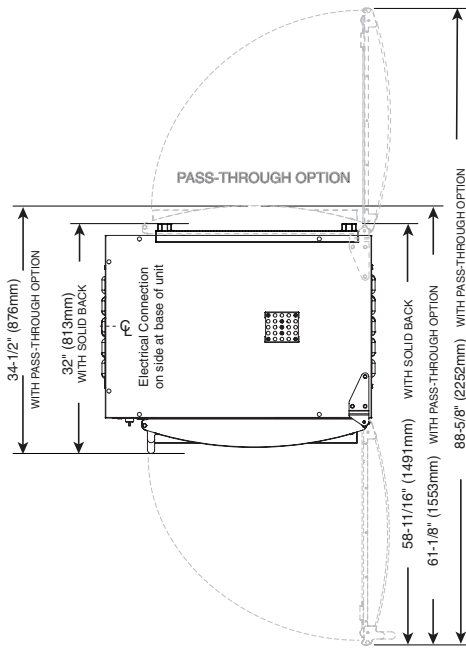

FRONT VIEW

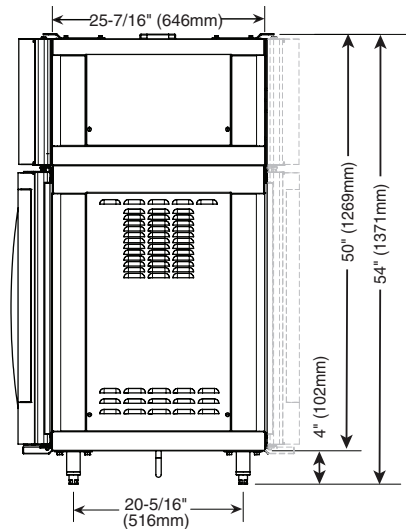

SIDE VIEW

DIMENSIONS: H x W x D

CURVED GLASS	
EXTERIOR: 54" x 39-1/16" x 32" (1371mm x 992mm x 813mm)	PASS-THROUGH EXTERIOR (OPTION): 54" x 39-1/16" x 34-1/2" (1371mm x 992mm x 876mm)
FLAT GLASS (NOT SHOWN)	
EXTERIOR: 54" x 39-1/16" x 32-1/8" (1371mm x 992mm x 815mm)	PASS-THROUGH EXTERIOR (OPTION): 54" x 39-1/16" x 33-15/16" (1371mm x 992mm x 863mm)

ELECTRICAL

VOLTAGE	PHASE	CYCLE/HZ	AMPS	kW	
208 (AGCY)	1	60	40.0	8.4	BARE END NO PLUG
240 (AGCY)	1	60	38.0	8.9	
208 (AGCY)	3	60	33.0/ph	8.4	BARE END NO PLUG
240 (AGCY)	3	60	32.0/ph	8.9	
380-415 (AGCY)	3	50	24.0/ph	8.9	
380	3	50	22.0/ph	7.5	NO CORD NO PLUG
415	3	50	24.0/ph	8.9	

AIR MOVEMENT

530 cfm (15m³)

OPTIONS & ACCESSORIES

Replacement Filters
 Grease Filter FI-25867 Charcoal Filter FI-25866

CLEARANCE REQUIREMENTS

6" (152mm) at top, back and both sides

WEIGHT

AR-7EVH:
NET: 481 lb (218 kg) **SHIP:** 568 lb (258 kg)

CRATE DIMENSIONS: (L x W x H)
 53" x 45" x 65" (1346mm x 1143mm x 1651mm)

INSTALLATION REQUIREMENTS

- The AR-7EVH must not be installed in any area where it may be affected by steam, grease, dripping water, high temperatures, or any other severely adverse conditions.
- **Power Cord Connection:** The side connection is recommended for all applications. If bottom connection is necessary for counter top units, user will need to provide a cutout in the countertop to allow the cord to hang freely without crimping.



W164 N9221 Water Street • P.O. Box 450 • Menomonee Falls, Wisconsin 53052-0450 • U.S.A.
 PHONE: 262.251.3800 800.558.8744 U.S.A./CANADA FAX: 262.251.7067 800.329.8744 U.S.A. ONLY

www.alto-shaam.com