

# ITM2-72

## ISLAND TAKEOUT MERCHANDISER



ITM2-72 (Standard)



- Freestanding, self-service merchandiser designed to provide quality hot packaged foods with minimum labor costs.
- Lighted display maximizes visual merchandising — promotes impulse sales.
- Heat source radiates from the base and the upper canopy with adjustable temperature settings.
- Concealed power and temperature switches are easily accessible to the operator.
- Angled canopy on two sides adds to the clean streamlined look.
- Bumpers on two sides of the unit provide extra protection against damage from shopping carts.

20 gauge stainless steel island base features bumpers on two sides, comes standard with two (2) black painted side panels and two (2) black painted adjustable shelves. An easy to clean hard coat anodized heat plate is surrounded by 2-1/2" (64mm) removable heat guards. The overhead canopy is supported by two (2) side supports, enclosing eight (8) flood lamps and is surrounded by four (4) removable tinted lexan heat guards. Two (2) toggle switches located beneath the canopy control the power (ON/OFF) and the heat plate temperature (LOW/MEDIUM/HIGH). The base is furnished with four (4) 5" (127mm) casters, 2 rigid, and 2 swivel with brake.

**MODEL ITM2-72/CT:** Countertop Island Take-out Merchandiser, 72" wide

**MODEL ITM2-72:** Floor Standing Island Take-out Merchandiser, 72" wide



ANSI/NSF 4



### FACTORY INSTALLED OPTIONS

- Electrical Choices
  - Specify Voltage:
    - 120V
    - 230V
- System Decorator Base (floor standing)
  - Specify model:
    - Standard - includes stainless steel base, black side panels, and two (2) black adjustable shelves.
    - Deluxe - features black formica end panels and black painted canopy, four (4) wooden adjustable shelves and two (2) removable wooden side baskets.
- Panel Color Choices
  - Specify color:
    - Black, standard
    - Stainless Steel, optional
    - Custom Color, optional
- Full Side Guards, Lexan



# ITM2-72

## ISLAND TAKEOUT MERCHANDISER

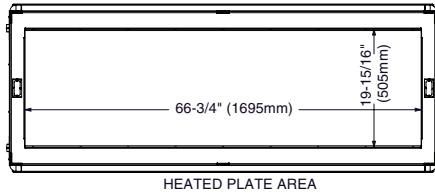

HEATED PLATE AREA

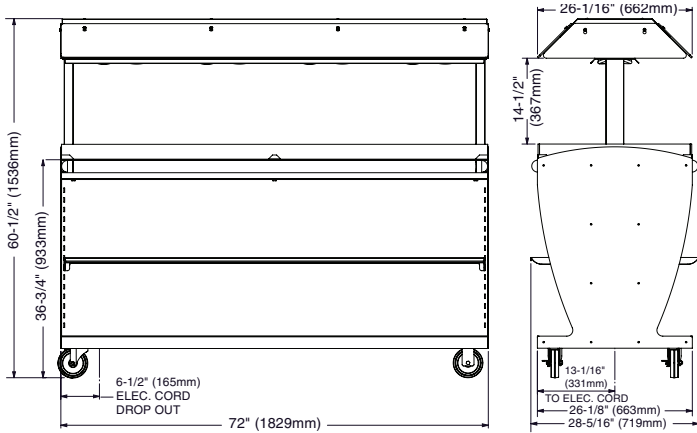

**ITM2-72/STD**

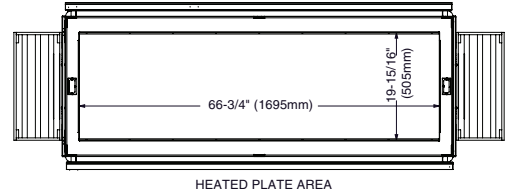

HEATED PLATE AREA

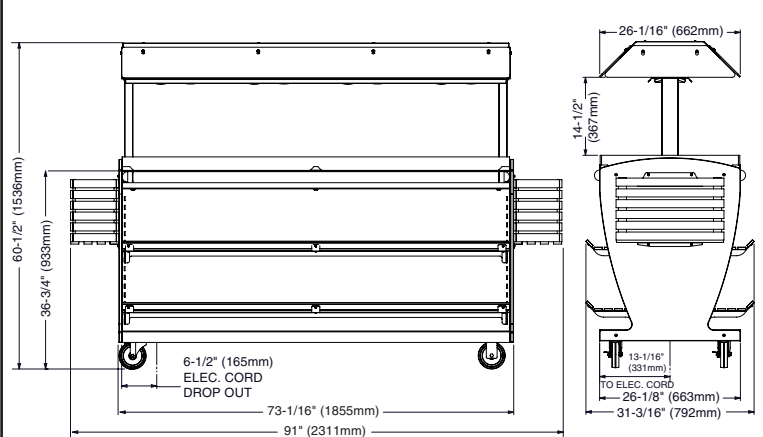

**ITM2-72/DLX**

### WEIGHT

	ITM2-72/STD	ITM2-72/DLX
<b>NET</b>	355 lb (161 kg) EST.	375 lb (170 kg)
<b>SHIP</b>	590 lb (268 kg) EST.	610 lb (277 kg)
<b>CRATE DIMENSIONS: (L x W x H)</b>		
	84" x 38" x 68"	
	(2134mm x 965mm x 1727mm)	

### DIMENSIONS: H x W x D

#### STANDARD:

60-1/2" x 72" x 28-5/16" (1536mm x 1829mm x 719mm)

#### DELUXE:

60-1/2" x 91" x 31-3/16" (1536mm x 2311mm x 792mm)

#### HEATED SURFACE DIMENSIONS: (L x W)

66-3/4" x 19-15/16" (1695mm x 505mm)

### INSTALLATION REQUIREMENTS

Unit must be installed level, and must not be installed in any area where it may be affected by steam, grease, dripping water, high temperatures, or any other severely adverse conditions.

### ELECTRICAL

VOLTAGE	PHASE	CYCLE/HZ	AMPS	kW	CORD & PLUG
120	1	50/60	16.0	1.9	NEMA 5-20P 20A - 125V Plug
230	1	50/60	9.7	2.4	CORD INCLUDED NO PLUG

### CLEARANCE REQUIREMENTS

NO CLEARANCE REQUIRED

### HEATED PRODUCT CAPACITY\*

63 lb (29 kg) MAXIMUM

Twenty-one (21) chicken boats with dome cover

DOME PACKAGE SIZE: APPROX. 7" x 10" (178mm x 254mm)

\*FOR USE WITH PRE-PACKAGED ITEMS ONLY



W164 N9221 Water Street • P.O. Box 450 • Menomonee Falls, Wisconsin 53052-0450 • U.S.A.

PHONE: 262.251.3800 800.558.8744 U.S.A./CANADA FAX: 262.251.7067 800.329.8744 U.S.A. ONLY

[www.alto-shaam.com](http://www.alto-shaam.com)

