



Combo Cart™ PLUS, Tall, Electric Double Compartment

For Full and Half Size Sheet Pans, GN Food Pans, Trays and/or Pizza Boxes

110V Models:

CMBPH, CMBPHHD, CMBPTH, CMBPTHHD

220V Models:

CMBPH2, CMBPH2HD, CMBPTH2, CMBPTH2HD



Features & Benefits

- Unique and versatile, heavy duty electric cart with two separate compartments safely holds hot food electrically for as long as needed. Can also hold hot or cold food safely for 4 hours or more, even when unplugged during transport.
- Perfect for use in schools and colleges, large institutions, banquet facilities or catering to hold and transport bulk food at safe temperatures.
- Tough, durable polyethylene exterior stays cool to the touch and will never dent, crack, chip or rust.
- Thick CFC-free polyurethane insulation throughout cabinet body and doors ensures excellent food temperature holding.
- Heavy-duty, gasket-free, self-venting, vaulted doors open 240° to the side and close flush to the cart.
- Wide, lockable, paddle door latches for easy one-handed opening and closing.
- Spherical bearing plastic door hinges are extra strong and will never rust.
- Energy efficient 529W (for 110V Models) or 506W (for 220V Models) door heaters are pre-set at a safe temperature range of 150°F -165°F (65,6°C – 73,9°C). Gentle, non-radiant heat circulates from front to back of each compartment to maintain food quality. Heaters automatically turn on and off to regulate compartment temperature.
- Power On and Heat On indicators on the front of each compartment door communicate the power and heating status of the unit. RED for power on. AMBER light turns on when compartment has reached its target temperature. Easily turn on or off without having to unplug the unit.
- Removable 9' (2,7 m) power cord with NEMA plug on each door stores conveniently during non-use in cord keeper.
- Solar digital door thermometer displays internal compartment temperature at a glance. Factory set for Fahrenheit for 110V models and Celsius for 220V models.
- Slide a standard 5" x 8" (12,7 x 20,3 cm) index card into door Menu Pocket or write directly onto the smooth surface with a grease pencil to identify contents, event or location. Clear plastic panel protects any signage.
- Fourteen pairs of adjustable Universal rails made of Type 304, 16-gauge stainless steel hold full and half size sheet pans, GN food pans, trays and pizza boxes. All items are bottom load except 40 x 60 cm tray is lip load. Add more rail sets to increase holding capacity.
- Two each Type 304, 16-gauge stainless steel column panels per compartment are factory installed on each side to hold rails level and securely in position. Notches for rails are spaced at 3/8" increments.

Item No. _____

Specifier Identification No. _____

Model No. _____

Quantity _____

- Ergonomic vertical, molded-in rear handles will never break and provide great maneuverability by operators of all heights.
- Molded-in, sleek perimeter bumper offers extra protection for carts and walls.
- Two non-marking caster choices available--all swivel and all with brakes, ensure smooth navigating and easy positioning into transport vehicles.

Models CMBPH, CMBPH2, CMBPTH, CMBPTH2:

Standard High Performance Casters, 6" x 1 1/4" (15 x 3,2 cm)

Models CMBPHHD, CMBPH2HD, CMBPTHHD, CMBPTH2HD

Heavy Duty, High Modulus Casters, 6" x 2" (15 x 5 cm)

- Minimal assembly required.
- Available in 1 color.



CMBPHHD

Approvals



Combo Cart™ PLUS, Tall, Electric Double Compartment

For Full and Half Size Sheet Pans, GN Food Pans,
Trays and/or Pizza Boxes

110V Models:

CMBPH, CMBPHHD, CMBPTH, CMBPTHHD

220V Models:

CMBPH2, CMBPH2HD, CMBPTH2, CMBPTH2HD

Electrical Specifications (Per Compartment)

	110V MODELS	220V MODELS
REQUIRED VOLTAGE	100-125 VAC	200-230 VAC
MAXIMUM AMP	4.6a	2.3a
WATTS	529w	506w
HERTZ	50/60	50/60
PHASE	Single	Single
PLUG TYPES	5-15 to C15RA	CEE7/7 to C15RA
ALTERNATE PLUG TYPES FOR INTERNATIONAL	JIS8303 to C15RA (Japan)	BS1363 to C15RA (UK / Ireland+more)
POWER CORD LENGTH	9 ft.	2,7 m

Pre-heat time: approx. 45 minutes

Recovery time: 3 minutes

Holding Capacity per Cart

TYPE OF CONTAINER	STANDARD	RAIL SPACING	MAXIMUM	RAIL SPACING
18" x 26" (45,7 x 66 cm) Full Size Sheet Pans	14	3 3/8" (8,6 cm)	32*	1 1/2" (3,8 cm)
13" x 18" (33 x 45,7 cm) Half Size Sheet Pans	28	3 3/8" (8,6 cm)	64*	1 1/2" (3,8 cm)
GN 1/1 Hotel Pans 2 1/2" (6,5 cm) Deep	28	3 3/8" (8,6 cm)	28	3 3/8" (8,6 cm)
GN 1/1 Hotel Pans 4" (10 cm) Deep	20**	5" (12,7 cm)	20**	5" (12,7 cm)
40 x 60 cm (20 1/2" x 23 1/2") Trays (Lip Load)	14	3 3/8" (8,6 cm)	32*	1 1/2" (3,8 cm)
32,5 x 53 cm (12" x 20") Trays	28	3 3/8" (8,6 cm)	52*	1 7/8" (4,7 cm)
Pizza Boxes 16" x 16" x 2" (40,6 x 40,6 x 5,1 cm)	14	3 3/8" (8,6 cm)	22	2 1/4" (5,7 cm)

*Additional rails required. **Only requires 5 pair of rails. Standard Capacity - Based on 14 pairs of rails included with cart

Item No. _____

Specifier Identification No. _____

Model No. _____

Quantity _____

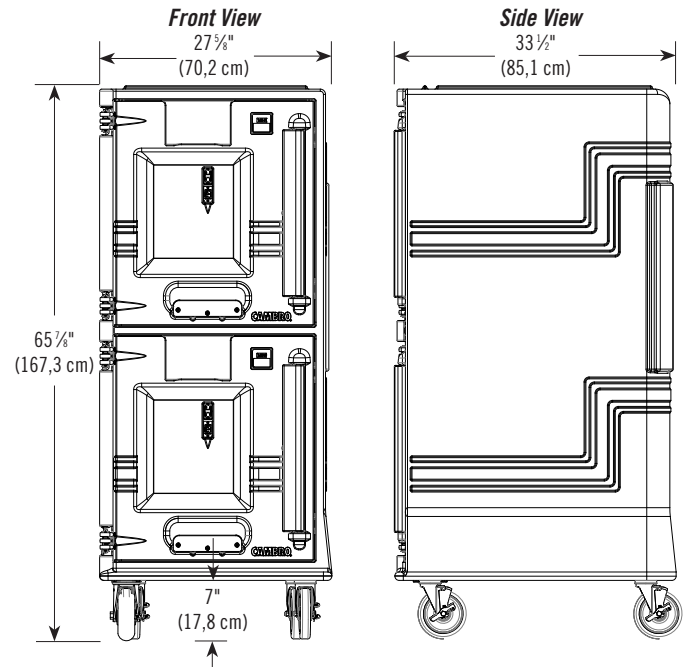

Specifications

Dimension Tolerance: +/- 1/4" (0,64 cm)

CODE	DESCRIPTION	DIMENSION ALL MODELS	CASE LBS.(CUBE)/CASE KG (M³)	UNIT WEIGHT LBS. (KG)
CMBPH	110V, Standard Casters	Exterior W x D x H: 27 3/8" x 33 1/2" x 65 7/8" (70,2 x 85,1 x 167,3 cm)	252.5 (42.5)/104,55 (1,2)	232 (105,2)
CMBPH2	220V, Standard Casters		252.5 (42.5)/104,55 (1,2)	232 (105,2)
CMBPHHD	110V, Heavy Duty Casters		262 (42.5)/118,84 (1,2)	241.5 (109,5)
CMBPH2HD	220V, Heavy Duty Casters		262 (42.5)/118,84 (1,2)	241.5 (109,5)
CMBPTH	110V, Top Door Heated only, Standard Casters	Compartment W x D x H: 21 1/8" x 26 1/4" x 25 1/2" (53,7 x 66,7 x 64,8 cm)	251 (42.5)/113,85 (1,2)	230.5 (104,6)
CMBPTH2	220V, Top Door Heated only, Standard Casters		251 (42.5)/113,85 (1,2)	230.5 (104,6)
CMBPTHHD	110V, Top Door Heated only, Heavy Duty Casters		260.5 (42.5)/118,16 (1,2)	240 (108,9)
CMBPTH2HD	220V, Top Door Heated only, Heavy Duty Casters		260.5 (42.5)/118,16 (1,2)	240 (108,9)

Optional Accessories

- CMBPR1 1 Set of Rails
- CMBPR7 7 Sets of Rails

Standard Color

- Charcoal Gray (615)

Approvals



Architect Specs

The tall, electric bulk food holding and transport cart shall be a Combo Cart Plus, Model CMBPH, CMBPHHD, CMBPH2 and CMBPH2HD.manufactured by Cambro Mfg. Co., Huntington Beach, CA 92647 USA. It shall have 2 separate compartments and shall be made of double wall, high-density, durable polyethylene and foam-injected CFC-free polyurethane. It shall have 28 each 304 Series, 16-gauge stainless steel, universal rails which will hold Full and Half Size Sheet Pans, GN 1/1 Full Size Food Pans, Trays and Pizza Boxes. It shall have 2 each 304 Series, 16-gauge stainless steel rail column panels per compartment with notches at 3/8" (0,95 cm) increments. It shall have a non-corrosive heating unit installed in each door with fans that gently circulate non-radiant heat throughout each compartment. It shall be Energy Star qualified. It shall heat the internal compartment to 150°F (65°C) in 1 hour or less from ambient room temperature and shall electrically maintain a factory set temperature of 150°F - 165°F (65°C - 74°C). Each heater shall have voltage requirements of 100-125 VAC, 4.6 maximum amps and 529 watts for 110V models and 200-230 VAC, 2.3 maximum amps and 506 watts for 220V models. Each heater shall have a 9' (2,7 m) removable cord with a 5-15 to C15RA plug type for 110V models or a CEE7/7 to C15RA plug type for 220V models. The front of each door shall have a cord pocket, a power ON and heat ON indicator light and a built-in solar digital thermometer. Doors shall be vaulted, gasket free and self-venting. Each door shall have plastic, spherical bearing hinges, a durable, wide, paddle latch that can be secured with a locking tie strap and a 5" x 8" (12,7 x 20,3 cm) menu pocket with clear panel. It shall have molded-in vertical rear handles and a molded-in sleek perimeter bumper. It shall have four swivel, all with brake, non-marking standard 6" x 1 1/4" (15 x 3,2 cm) casters or heavy-duty 6" x 2" (15 x 5 cm) casters. It shall require minimal assembly. It shall be available in Charcoal Gray (615) only.

CAMBRO
www.cambro.com

Telephone 714 848 1555

Toll Free 800 854 7631

Customer Service Department 800 833 3003

© Cambro Manufacturing Company 5801 Skylab Road, Huntington Beach, CA 92647-2056, U.S.A.