



Meal Delivery Carts

Low Profile, Double Door, 20 Tray Capacity

Models MDC1520S20
MDC1418S20

Features & Benefits

- Durable carts designed to specifically meet the meal delivery needs of hospitals (acute care), long term care and correctional facilities.
- Designed to work with unitized pellet system, heat on demand base system or insulated trays.
- Single stack rail system handles two (2) trays per rail, ten (10) trays per compartment with a 5 1/2" (14 cm) clearance between rails.
- Meal serving capacity per compartment is ten (10) each 15" x 20" (38,1 x 50,8 cm) or 14" x 18" (35,6 x 45,7 cm) fully loaded trays.
- Durable, one-piece, molded polyethylene construction ensures long term durability and reliability. Molded bottom bumpers protect walls and furniture.
- Thick foamed-in place polyurethane insulation provides added structural strength and reduces noise while transporting.
- MDC1520S20 has two (2) lightweight, non-rusting, aluminum louvered vents on the back of the cart for increased air circulation which optimizes food quality.
- Molded-in marine rail top provides an ergonomic work surface and keeps trays secure during service preparation. Marine rail is designed for use during service, not transport.
- Molded-in handles on both ends make it easy to transport and maneuver.
- ABS doors are non-insulated, durable and open out and over side bumper for clear access to the full tray width. These doors are self venting to assist with air circulation.
- Nylon friction latches ensure that doors close securely.
- Self-draining bottom in each compartment facilitates easy cleaning.
- Stainless steel casters:
MDC1520S20: Four (4) each 6" (15,24 cm) non-marking slightly offset casters, two (2) swivel with brakes and two (2) rigid.
MDC1418S20: Four (4) each 5" (12,7 cm) non-marking slightly offset casters, two (2) swivel with brakes and two (2) rigid.
- Non electrical.
- No assembly required.
- Available in five (5) colors.

Item No. _____

Specifier Identification No. _____

Model No. _____

Quantity _____

Louvered Vents



MDC1520S20



MDC1418S20

Approvals



© Cambro Manufacturing Company 5801 Skylab Road, Huntington Beach, California 92647-2056-U.S.A.
Telephone 714 848 1555 Toll Free 800 854 7631 Customer Service 800 833 3003

Meal Delivery Carts

Low Profile, Double Door, 20 Tray Capacity

Models MDC1520S20
MDC1418S20

Item No. _____

Specifier Identification No. _____

Model No. _____

Quantity _____

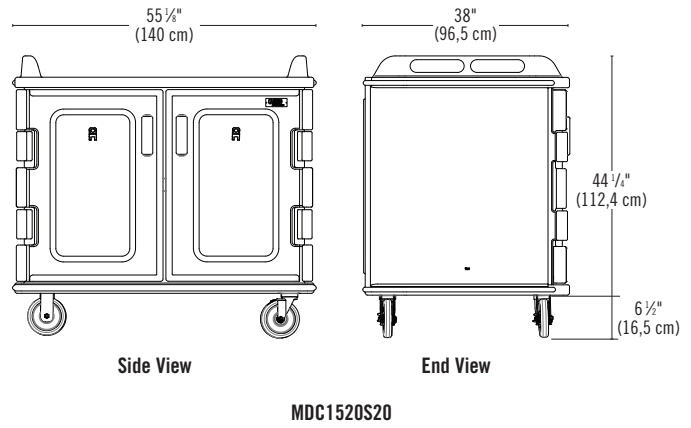
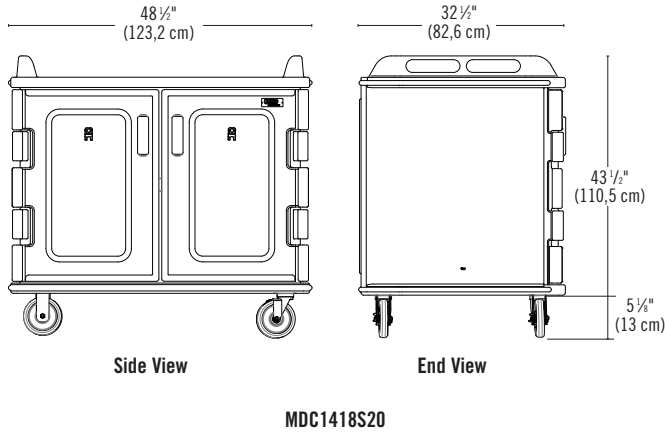

Specifications

Dimension Tolerance: +/- 1/4" (0,64 cm)

CODE	TRAY CAPACITY PER COMPARTMENT	EXTERIOR DIMENSIONS L X W X H	INTERNAL DIMENSIONS L X W X H	UNIT WEIGHT LBS. UNIT WEIGHT KG	CASE LBS./CUBE CASE KG/CUBE M ³
MDC1520S20	20 each 15" x 20" (38,1 x 50,8 cm)	55 1/2" x 38" x 44 1/4" (140 x 96,5 x 112,4 cm)	20 1/2" x 30 1/4" x 27 1/2" (52,1 x 76,8 x 69,9 cm)	155 70,3	177.5 (60.79) 80,5 (1,72)
MDC1418S20	20 each 14" x 18" (35,6 x 45,7 cm)	48 1/2" x 32 1/2" x 43 1/2" (123,2 x 82,6 x 110,5 cm)	18 3/8" x 28 3/8" x 28" (46,7 x 72,7 x 71,1 cm)	138.4 62,8	160 (49.7) 72,6 (1,41)

Architect Specs

These non-electric carts shall be Low Profile, Double Door, Double Compartment, 20 Tray Capacity Meal Delivery Carts, Model MDC1520S20 and MDC1418S20, manufactured by Cambro Mfg. Co., Huntington Beach, CA 92647, USA. They shall be made of one-piece, seamless, double-wall, high-density, polyethylene and shall be foam injected with polyurethane. They shall have molded-in handles on each end. They shall have molded-in marine top rails and a work surface for tray set-up and service. They shall have non-insulated, ABS doors that open out and over side bumper for clear access to full tray width. They shall have single stack rail system that holds 2 trays per rail, 10 trays per compartment with a rail clearance of 5 1/2" (14 cm). They shall have internal nylon friction latches; one per door. They shall have self-draining compartment floors that are slightly sloped. The MDC1418S20 shall have four (4) each 5" (12,7 cm) stainless steel casters, two (2) swivel with brakes and two (2) rigid, offset. The MDC1520S20 shall have four (4) each 6" (15,24 cm) stainless steel casters, two (2) swivel with brakes and two (2) rigid, offset. The MDC1520S20 shall have two (2) each aluminum vents on the back of the cart. They shall require no assembly. They shall be available in five (5) colors.

Standard Colors

- Gray (180)
- Slate Blue (401)
- Granite Gray (191)
- Granite Green (192)
- Granite Sand (194)

Approvals



© Cambro Manufacturing Company 5801 Skylab Road, Huntington Beach, California 92647-2056-U.S.A.
Telephone 714 848 1555 Toll Free 800 854 7631 Customer Service 800 833 3003