

VALUE LINE SOLID TOP & BEVERAGE URN STAND COUNTERS

ValuXpress®

Item Numbers

- DXDVLST2
- DXDVLST3
- DXDVLUS2
- DXDVLUS3

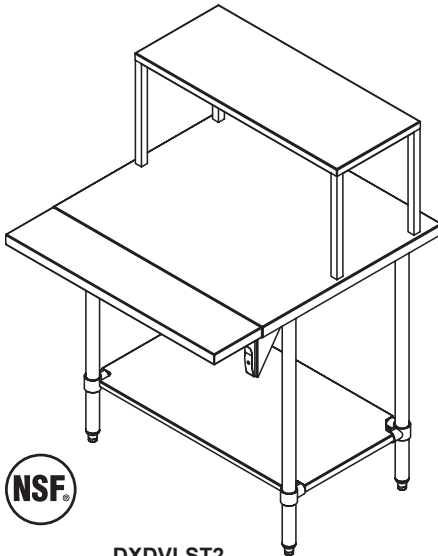

DXDVLST2
Shown with optional overhead, drop down work and under shelves

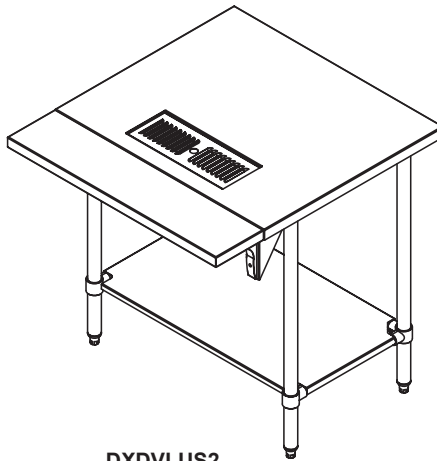

DXDVLUS2
Shown with optional drop down work and under shelves

Application

The ValuXpress Value Line Solid Top & Beverage Urn Stand Counters offers an economical alternative to the way you present your food.

Construction

General: The Dinex Value Line Solid Tops and Beverage Urn Stand Units shall have a 16-gauge stainless steel top with 1-1/2" turn down on all sides. The legs shall be 1-5/8" stainless steel.

Casters: The Dinex Value Solid Tops and Beverage Urn Stands Units are provided with adjustable feet. Optional 5" diameter, heavy-duty, swivel casters two fitted with brakes are available.

Options

- Drop down work shelf
- Over head shelf
- Under shelf
- Casters
- 3-Bar Tray slide

Warranty

One year parts and labor.

We do not accept returns on any Dinex equipment or Dinex custom products. Please contact your local Dinex rep to ensure order accuracy prior to ordering.

VALUE LINE SOLID TOP & BEVERAGE URN STAND COUNTERS

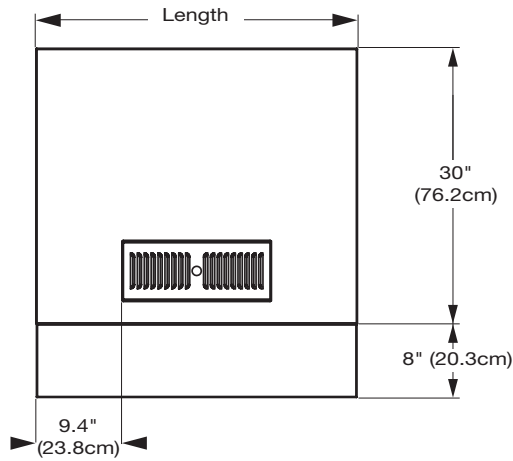
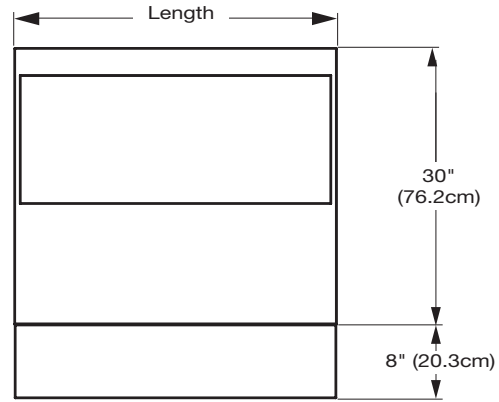
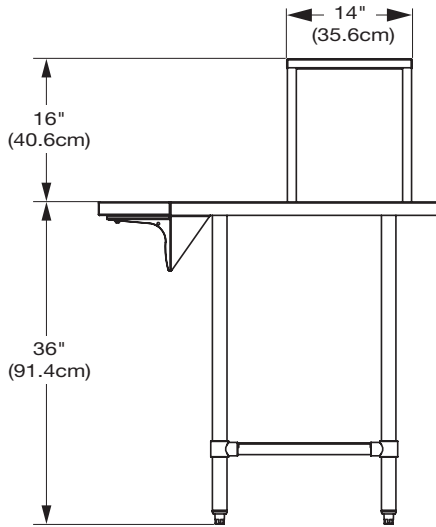

Items and Dimensions

ITEM NUMBER	MODEL NUMBER	LENGTH	DEPTH	HEIGHT	SHIP WEIGHT	SHIP CUBE
DXDVLST2	DVLST/2	35" (88.9cm)	30" (76.2cm)	36" (91.4cm)	145 lb. (65.8kg)	15.6
DXDVLST3	DVLST/3	49" (124.5cm)	30" (76.2cm)	36" (91.4cm)	190 lb. (86.2kg)	23.8
DXDVLUS2	DVLUS/2	35" (134.6cm)	30" (76.2cm)	36" (91.4cm)	145 lb. (65.8kg)	15.6
DXDVLUS3	DVLUS/3	49" (124.5cm)	30" (76.2cm)	36" (91.4cm)	190 lb. (86.2kg)	23.8



4711 E Hefner Road
 Oklahoma City, OK 73131
 800.654.8210 • 405.475.5600
www.dinex.com

Please confirm that you have the most current specification sheet by visiting www.dinex.com.
 Dinex® reserves the right to change specifications and product design without notice.
 Such revisions do not entitle the buyer to corresponding changes, improvements,
 additions or replacements for previously purchased equipment.