

TQ ECONOMY CART – ENCLOSED

Accommodates 14" x 18" and 15" x 20" Trays and Dinex Room Service Tray DXRST152003

Compliant with
NSF/ANSI Standard 2



DXPICT16

Application

The TQ Economy Cart, single door delivery cart is designed for transport of patient meals to decentralized locations. The all stainless steel cart features fixed tray slides with 5.25" spacing. This cart will accommodate 14"x 18" and 15" x 20" trays and Dinex Room Service Tray DXRST152003, 2 trays per slide.

Construction

Dinex® TQ Economy Carts has a 1" 18-gauge tubular frame with welded 18-gauge pre-formed side panels/tray slides. Top, bottom and single panel door is of 18-gauge, stainless steel. Door has recessed door pull with a top mounted heavy duty drop door latch. The door has a 270° swing with magnets to keep the door in an opened position.

Casters

Four 5" diameter plate-type, 2 fixed, 2 swivel with brakes.

Standard Features

- All stainless steel
- Pull type door handle
- Drop latch with magnets
- Small footprint
- Plate-type 5" casters, 2 with brakes

Item Numbers

DXPICT16
DXIPCT20
DXPICT24

Pass-Thru Model

DXPICTPT16
DXPICTPT20
DXPICTPT24

Options

- Wrap around bumpers*
- Corner bumpers
- Push handle

Warranty

One year parts and labor.

* Wrap around bumper option adds 2" to the overall length and depth

TQ ECONOMY CART – ENCLOSED

Accommodates 14" x 18" and 15" x 20" Trays and Dinex Room Service Tray DXRST152003

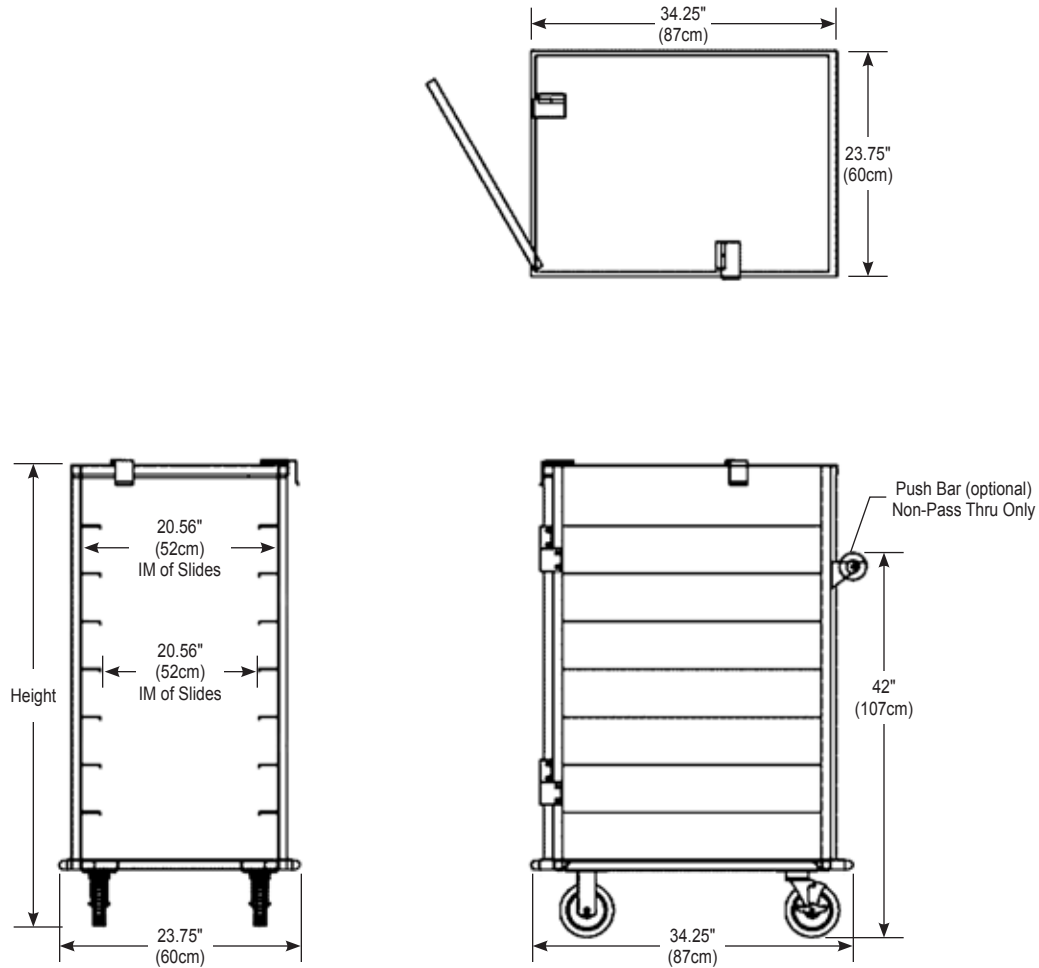

Items and Dimensions

ITEM NUMBER	LENGTH*	DEPTH	HEIGHT	SHIP WEIGHT	SHIP CUBE	TRAY SPACING	TRAY CAPACITY
DXPICT16 DXPICTPT16	23.75" (60cm)	34.25" (87cm)	54" (137cm)	275 lb. (125kg) 285 lb. (129kg)	27.1	5.281"	16
DXPICT20 DXPICTPT20	23.75" (60cm)	34.25" (87cm)	65.25" (166cm)	295 lb. (134kg) 305 lb. (138.5kg)	32.2	5.281"	20
DXPICT24 DXPICTPT24	23.75" (60cm)	34.25" (87cm)	76.5" (194cm)	315 lb. (143kg) 325 lb. (147kg)	37.2	5.281"	24

* Wrap around bumper option adds 2" (5cm) to the overall length and depth

Please confirm that you have the most current specification sheet by visiting www.dinex.com.

It is Dinex's policy to offer equipment which is design certified by companies that have been accredited at the federal level by the Occupational Safety and Health Agency (OSHA) and ANSI as a national recognized testing laboratory. These companies include CSA International, Underwriters Laboratories, Edison Testing Laboratories and National Sanitation Foundation. However, a continuing program of product improvement makes it necessary to submit new models to the agencies as they are developed. Consequently, all models may not bear the appropriate labels at all times.

Dinex reserves the right to change specifications and product design without notice. Such revisions do not entitle the buyer to corresponding changes, improvements, additions or replacements for previously purchased equipment.



DINEX®

4711 E. Hefner Road
Oklahoma City, OK 73131
800.654.8210 | 405.475.5600
www.dinex.com