



**Project:**  
**Item Number:**  
**Quantity:**

**COMMERCIAL COUNTERTOP INDUCTION RANGE**



**DESCRIPTION**

The portable countertop induction range is designed for use in light to medium-duty front-of-the-house cooking.

The induction range is equipped with a variety of safety features including:

- Over-heat protection
- Small-article detection
- Pan auto-detection function
- Empty-pan shut-off
- Safety auto-shut-off function

**AGENCY LISTINGS**

**6950020**



This device complies with Part 18 FCC Rules.

**6951020**



This device complies with Part 18 FCC Rules.

**ITEMS**

- 6950020** Countertop Induction Range, 1800 watts (US Only)
- 6951020** Countertop Induction Range, 1400 Watt s (US and Can)

**FEATURES**

- Power level and temperature control
- 9 heating levels
- 7 temperature holding positions
- 90% efficiency rating
- Easy to read LED bar for power level
- The case frame is made from 18-gauge stainless steel with a ceramic top
- Sloped control panel for runoff of liquid spills
- Push button controls for easy cleaning
- Warming function to maintain preset temperatures
- Rubber feet to prevent slipping of appliance
- 6 ft. (183 cm) with plug

**WARRANTY**

All models shown come with Vollrath’s standard warranty against defects in materials and workmanship. For full warranty details, please refer to [www.Vollrath.com](http://www.Vollrath.com).

**CLEARANCE AND ENVIRONMENT REQUIREMENTS**

- This appliance is intended for use with induction-ready cookware. It is not intended to be used with aluminum pans with a metal disk on the bottom.
- All models require adequate unrestricted intake and exhaust air ventilation for proper operation of the controls. The maximum intake temperature must not exceed 110°F (43°C). Temperatures are measured in ambient air while all appliances in the kitchen are in operation.
- Countertop models require a minimum clearance of 4 inches (10.2 cm) at the rear and 1 inch (2.5 cm) at the bottom.

Due to continued product improvement, please consult [www.vollrath.com](http://www.vollrath.com) for current product specifications.

Approvals	Date



[www.vollrath.com](http://www.vollrath.com)

**The Vollrath Company, L.L.C.**

1236 North 18th Street  
 Sheboygan, WI 53081-3201 U.S.A.  
 Main Tel: 800.624.2051 or 920.457.4851  
 Main Fax: 800.752.5620 or 920.459.6573  
 Customer Service: 800.628.0830  
 Canada Customer Service: 800.695.8560

Technical Services  
[techservicereps@vollrathco.com](mailto:techservicereps@vollrathco.com)  
 Induction Products: 800.825.6036  
 Countertop Warming Products: 800.354.1970  
 All Other Products: 800.628.0832

# COMMERCIAL COUNTERTOP INDUCTION RANGE

## DIMENSIONS (Shown in inches (cm))

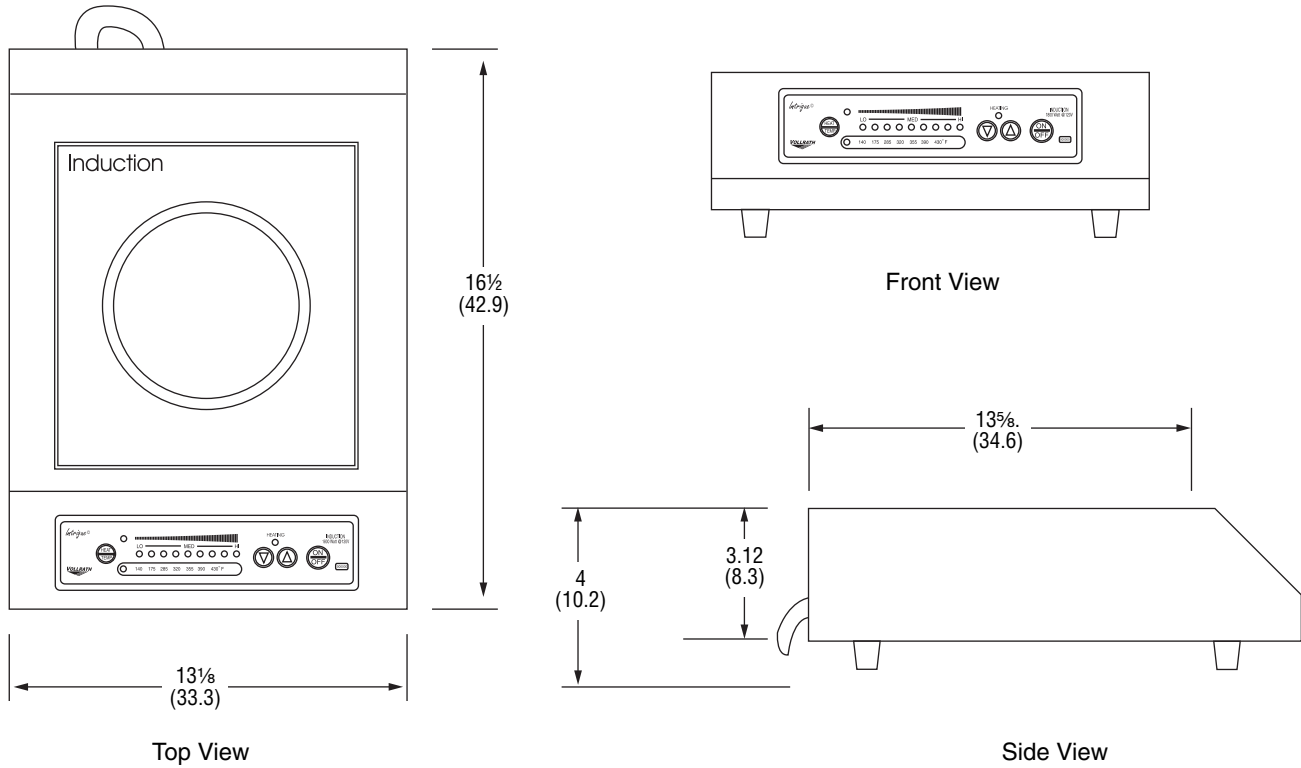

## SPECIFICATIONS

Item No.	Max Pan Diameter * IN (CM)	Watts	Volts	Amps	Phase	Hz	Plug	Weight LB (KG)
6950020	14	1800	120	15	Single	60	NEMA 5-15P	14 (6.3)
6951020	(35.6)	1400		12				

### Receptacle

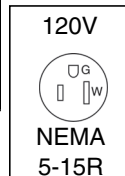

\* Maximum pan diameter is provided as a guideline for achieving maximum performance. Other factors impact performance including pan construction material, the density and volume of the food in the pan, ambient temperature and food temperature.



[www.vollrath.com](http://www.vollrath.com)

### The Vollrath Company, L.L.C.

1236 North 18th Street  
 Sheboygan, WI 53081-3201 U.S.A.  
 Main Tel: 800.624.2051 or 920.457.4851  
 Main Fax: 800.752.5620 or 920.459.6573  
 Customer Service: 800.628.0830  
 Canada Customer Service: 800.695.8560

### Technical Services

[techservicereps@vollrathco.com](mailto:techservicereps@vollrathco.com)  
 Induction Products: 800.825.6036  
 Countertop Warming Products: 800.354.1970  
 All Other Products: 800.628.0832