



**UNDERCOUNTER GLASSWASHER**  
**DOOR STYLE WITH HEATER**



PKD24A

JOB
AREA
ITEM NO.
MODEL NO.
PKD24A



MODEL NUMBERS		PKD24A
CABINET DIMENSIONS	Length - in. (mm)	24" (610)
	Depth - in. (mm)	24-3/4" (630)
	Height - in. (mm)	39-40-1/8" (990-1020)
MAX. CLEARANCE FOR GLASSWARE		11-1/4" (285.7 mm).
OPERATING CAPACITY		30 racks per hour.
OPERATING CYCLE		<b>Wash time:</b> 57 seconds. <b>Rinse time:</b> 48 seconds. <b>Dwell time:</b> 15 seconds. <b>Total cycle time:</b> 120 seconds.
WASH TANK CAPACITY		1.7 gallons (6.45 liters).
WASH PUMP CAPACITY		35 gallons per minute (132 lpm).
DRAIN FLOW (gals. per cycle)		2
EXHAUST REQUIREMENTS		None.
MINIMUM TEMPERATURE REQUIRED		120° F (50° C) wash temperature.
WATER CONSUMPTION		1.7 gallons (6.45 liters) per rack. 40.8 gallons per hour (154.4 lph). 1/2" (12.7mm) water inlet. 1" (25mm) drain.
WASH PUMP MOTOR HP		1
STANDARD GLASS RACK DIMENSIONS		1 rack: 19-3/4" x 19-3/4" (500 x 500mm).
ELECTRICAL RATING		115 volts, 16 amps/ 230 volts, 50 hz.
SHIP WEIGHT LBS. (kg.)		244 (110.6).
PLUMBING		<b>Hot water inlet connection:</b> 1/2" NPT. <b>Incoming hot water:</b> 120° F minimum, 30-60 PSI. <b>Drain:</b> 1" NPT.
WATER HARNESS		Water containing more than 15 GPG will require a water softener. <b>Caution:</b> <i>Parts failure caused by hard water are not covered under the Perlick warranty.</i>
DETERGENT, SANITIZER AND RINSE AID		<b>Detergent:</b> A heavy-duty liquid warewashing detergent containing water conditioners. <b>Chlorine sanitizer:</b> Any EPA-registered chlorine can be used. The EPA marking can be found on the container label. <b>Rinse aid:</b> A low-foaming warewashing rinse aid containing water conditioners. <b>Note:</b> <i>To ensure maximum glasswasher performance, it is important to select the appropriate detergent and rinse aid for specific water conditions. These chemicals can be purchased from a local chemical supplier or foodservice distributor.</i>
SUMMARY SPECIFICATIONS		Model PKD24A undercounter chemical sanitizing commercial glasswasher is designed to produce sparkling clean glassware using the Perlick unique Hot Water Assurance System. The PKD24A is easy to use, fast and efficient, while conserving water, energy and chemicals. A built-in sustainer heater provides continuous 130° hot water every cycle. The PKD24A is constructed entirely of stainless steel and is equipped with an integrated chemical delivery system. The PKD24A incorporates a pump purging system that improves results by eliminating soil and chemical carryover during the rinse cycle.
AVAILABLE OPTIONS		Alternative electrical setup available for export.



**UNDERCOUNTER GLASSWASHER**  
DOOR STYLE WITH HEATER

**Perlick Features**

- 30 racks per hour.
- Economical to operate. Uses only 1.7 gallons of water per cycle.
- All stainless steel construction assures long life and years of trouble free operation.
- Unique spray arm system features upper and lower stainless steel wash arms with reinforced end caps.
- Built-in chemical pumps and deliming system assures proper chemical usage.
- Convenient to service "Works-in-a-drawer". All electrical components are attached to a sliding drawer for easy access and service.
- Instant start for simple operation.
- Built-in hot Water Assurance System guarantees hot water every cycle.
- Pump drain allows for flexible installations. No floor drain required.
- Wash tank sustainer heater keeps water at proper temperature between loads.



PKD24A

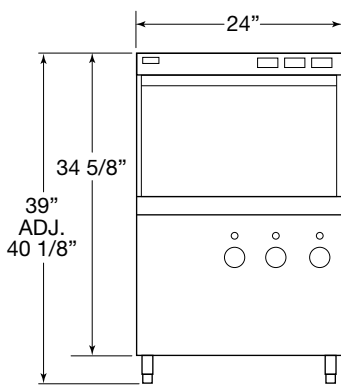

**FRONT VIEW**

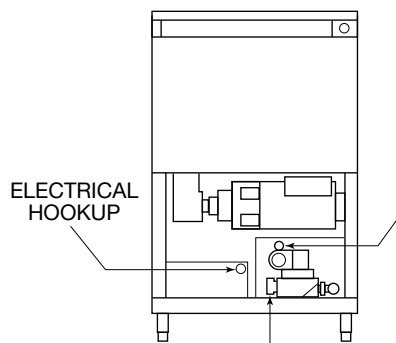

**REAR VIEW**

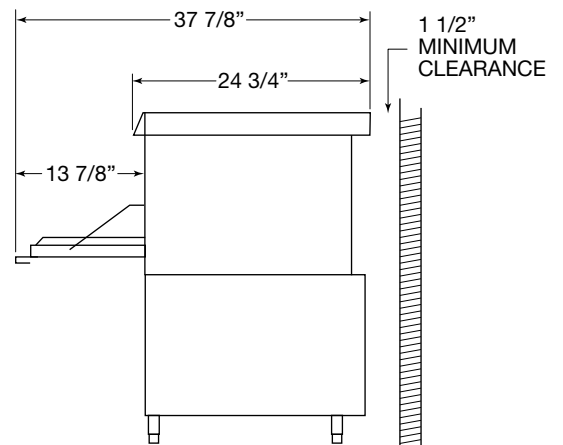

**RIGHT VIEW**