



The Signature of Quality

FEDERAL INDUSTRIES

A Standex Company
215 Federal Avenue
Belleville, WI 53508-9201

Phone: 800-356-4206
Fax: 608-424-3234
Email: geninfo@federalind.com
Website: www.federalind.com

Project Name: _____

Item #: _____

Model #: _____ Qty: _____

Approval: _____

AIA#

SIS#

WALL DISPLAY NON-REFRIGERATED, SELF-SERVE BAKERY CASE

Generate increased impulse sales with maximum product exposure.



Model WDC-42 Shown

| MODEL | DIMENSIONS |
|--------------------------------|---|
| <input type="checkbox"/> WDC42 | 42 x 30 x 62 (in) 1067 x 762 x 1575 (mm) |

STANDARD FEATURES

Model Features

- Tempered self-closing full view front service doors.
- Glass ends and top.
- All-welded base and frame construction with a choice of six standard laminates on base and counter top. Satin finish stainless steel trim. Other color laminates optional.
- Mirrored back panel.
- Base storage area with solid sliding doors.
- Bag bin with three dividers.
- Counter top with tissue holder (5-3/4" x 6-1/2" x 2-1/2")
- Sloped front providing high visual product display.

Shelving

- Four adjustable white epoxy-coated slanted shelves.

Lighting

- Vertical LED lights (Optional)

Agency Approvals

- UL and UL Sanitation listed to NSF-2

OPTIONAL ACCESSORIES

- Special Base Finish
- Vertical LED lights (includes NEMA 5-15P cord)
- Mirrored Ends Rear
- Sliding Doors
- Casters



WARRANTY*
One year Parts and Labor
2nd thru 5th year part
only service compressor
(U.S.A and Canada)

Note: Information is subject to change at any time.
Visit www.federalind.com for the most current specs.

Revised 02/10/2020

AIA#

WALL DISPLAY NON-REFRIGERATED, SELF-SERVE BAKERY CASE

SIS#

Product Specifications

| | |
|------|-----------------------------------|
| Zone | Intended product to be displayed |
| All | Non-Refrigerated Package Products |

DIMENSION: xx"/(mm)

DIMENSION TOLERANCE +/- 0.25 (6.4)

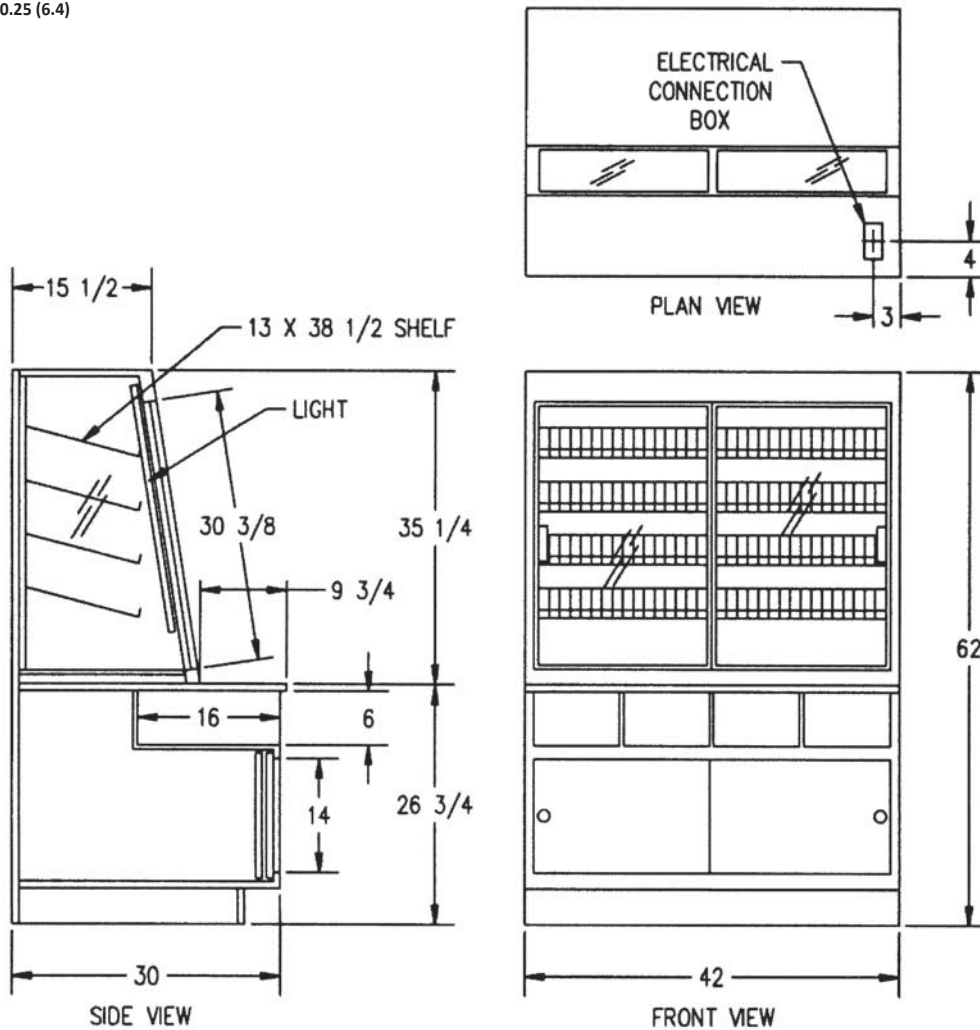

| MODEL | DIMENSIONS | | | | SHIPPING WHT | | CAPACITY (BAKERY PANS) |
|-------|------------|-----|------|-------|--------------|------|---------------------------|
| | L | D | H1 | UNITS | LBS | KILO | |
| WCD42 | 42 | 30 | 62 | in. | 615 | 279 | 10 (12" X 18") |
| | 1067 | 762 | 1575 | mm. | | | |

- If a GFCI circuit is required, a GFCI Breaker Must be used instead of a GFCI receptacle.
- Electrical requirements for optional lights - 120/60/1 - 2 AMPS.
- Due to continuing engineering improvements, specifications are subject to change without notice.



The Signature of Quality

FEDERAL INDUSTRIES

A Standex Company

215 Federal Avenue Belleville, Wisconsin 53508-9201

Phone: 800-356-4206

Fax: 608-424-3234

Email: Geninfo@Federalind.com

Website: Federalind.com