



Project _____
 AIA # _____ SIS # _____
 Item # _____ Quantity _____ C.S.I. Section 114000



G-SERIES

1-Section Refrigerator Pass-Thru Self-Contained Solid Door(s)



STANDARD PRODUCT FEATURES

- High Performance, Energy Efficient Refrigeration System
- Reliable Microprocessor Control With LED Temperature Display
- Evaporator Coil Outside Food Zone Provides More Usable Space
- Load-Sure Guard Prevents Problems From Improper Loading
- Durable All Metal Construction
- Stainless Steel Front & Doors, Anodized Aluminum Sides & Interior
- Full or Half Height Door Models with a Variety of Hinging Configurations
- Long Life EZ Clean Door Gaskets
- Three (3) Epoxy Coated Shelves Per Section (factory installed)
- Easy to Maintain Front Facing Condenser Coil
- 6" High Locking Casters
- Guaranteed for Life Door Handles & Hinges
- 3-Year Parts & Labor Warranty
- 2-Years Additional Compressor Parts Warranty

DEALERS CHOICE G-SERIES



This unit is listed to the applicable UL, CSA and NSF Standards by an approved NRTL. Consult the factory or unit's data plate for approval information.

ACCESSORIES & OPTIONS (*field installed)

- Tray Slides for 18" x 26" Sheet Pans*
- Tray Slides for 12" x 20" Food Pans*
- Tray Slides for 14" x 18" Sheet Pans*
- Tray Slides for 18" x 26, 12" x 20" & 14" x 18" Pans*
- Additional Shelves*
- 6" High Legs*
- Lower Height Casters*
- Optional Remote Applications

*Please refer to form number TR35872 for precise kit details. See back page for tray slide versatility chart.

AVAILABLE CONFIGURATIONS

Half-Height	Control Side	Non Control Side
Door Models	Hinging	Hinging
G10002P	Right	Right
G10003P	Right	Left
G10004P	Left	Left
G10005P	Left	Right
Full-Height	Control Side	Non Control Side
Door Models	Hinging	Hinging
G10012P	Right	Right
G10013P	Right	Left
G10014P	Left	Left
G10015P	Left	Right

SECTION 4-11

Approved by _____ Date _____ Approved by _____ Date _____



MODELS

Half Height Door Models: G10002P, G10003P, G10004P, G10005P

CLICK
TRANSFER 
 For KCL CADalog Website

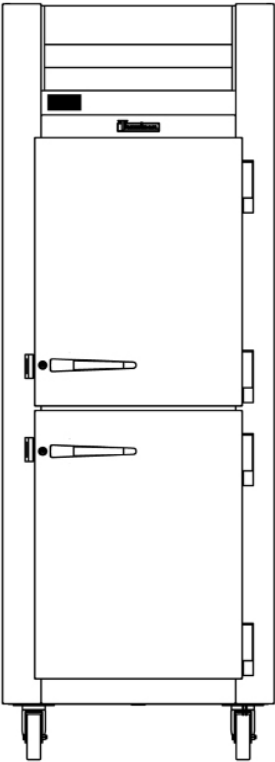

G10002P Control Side
 Hinged Right Shown
 (other hinging available)

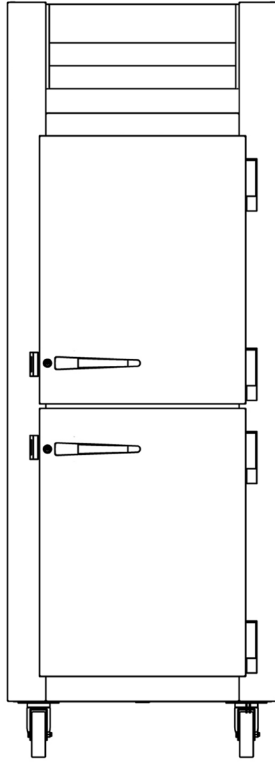

G10002P Non Control Side
 Hinged Right Shown
 (other hinging available)

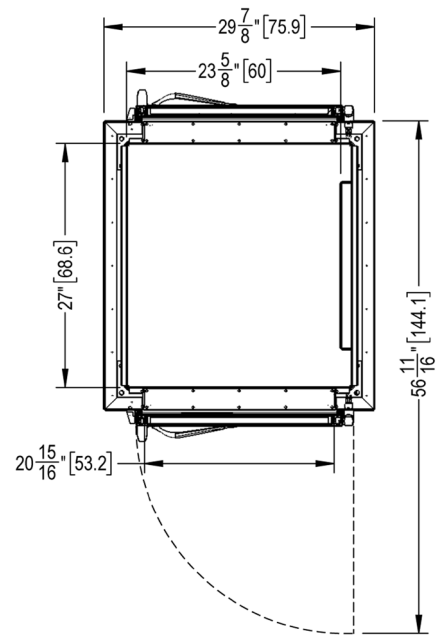
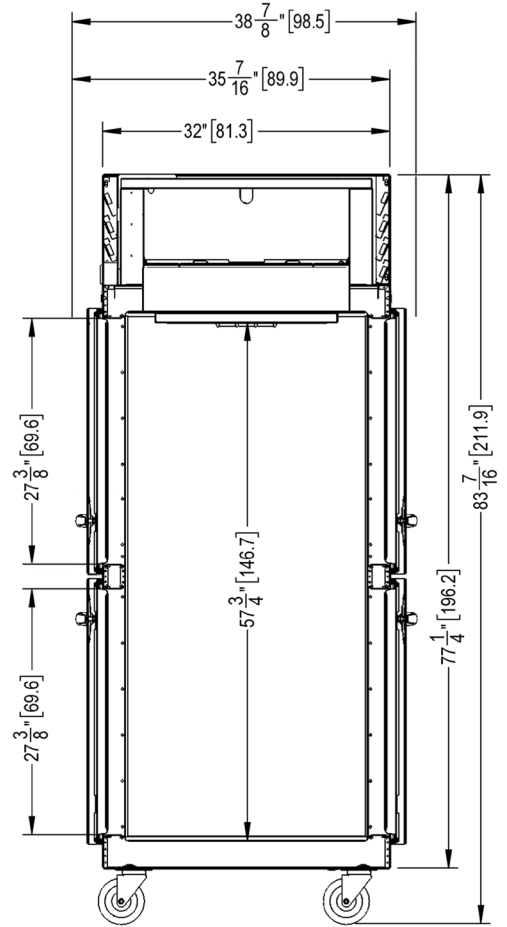

G-SERIES

1-Section Refrigerator Pass-Thru Self-Contained Solid Door(s)

MODELS

Full Height Door Models: G10012P, G10013P, G10014P, G10015P

CLICK
TRANSFER
For KCL CADalog Website

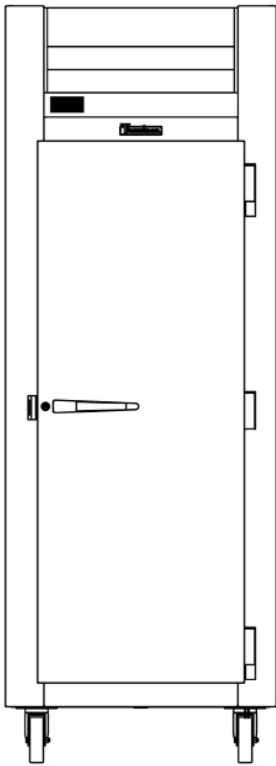

G10012P Control Side
Hinged Right Shown
(other hinging available)

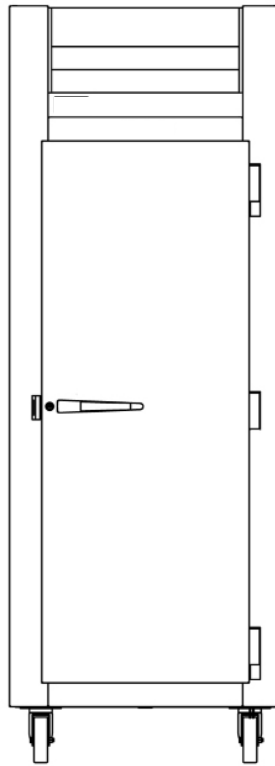

G10012P Non Control Side
Hinged Right Shown
(other hinging available)

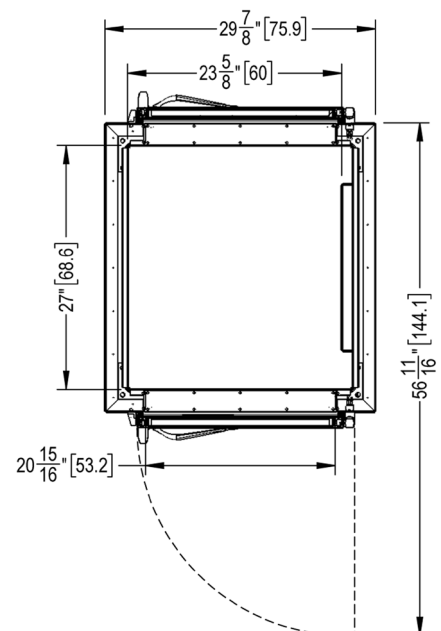
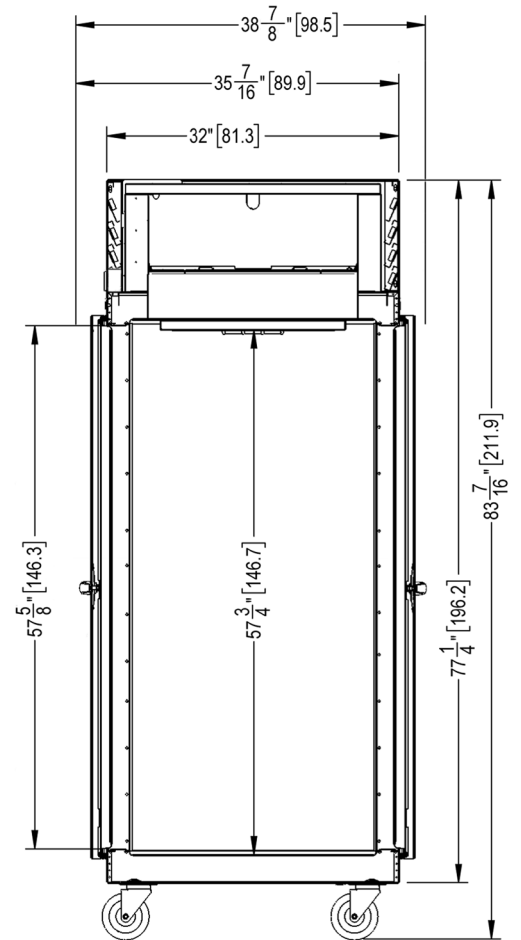



MODELS

Half Height Door Models: G10002P,G10003P, G10004P, G10005P

Full Height Door Models: G10012P,G10013P, G10014P, G10015P

MODELS	G100__P
DIMENSIONAL DATA	
Net Capacity cu. ft. ¹	24.72 (699.9 l) 24.85 (703.6 l)
L x D x H - Overall in. ²	29 ⁷ / ₈ (75.9 cm) x 37 ¹ / ₁₆ (96.4 cm) x 83 ³ / ₁₆ (211.9 cm)
Depth - over body in.	32 (81.3 cm)
Depth - door open 90° in.	57 ⁷ / ₈ (146.3 cm)
Clear half-door W x H in.	21 ¹ / ₈ (53.6 cm) x 27 ¹ / ₂ (69.9 cm)
Clear full-door W X H in.	21 ¹ / ₈ (53.6 cm) x 57 ⁷ / ₈ (146.3 cm)
No. Standard Shelves	3
Shelf Area sq. ft. ³	18.8 (1.75 sq m)
ELECTRICAL DATA	
Voltage Plug	115/60/1 NEMA 5-15P (attached)
Feed wires with ground	3
Full Load Amperes MDEC ⁴	4.9 2.47 KWH/Day
REFRIGERATION DATA	
Refrigerant	R-450A
Refrigerant Charge Amount	16 oz
BTU/HR H.P. ⁵	1650 1/5 HP
Required Clearance	12" Above
SHIPPING DATA	
L x D x H Crated in.	48 (122 cm) x 42 (107 cm) x 85 (216cm)
Volume Crated cu. ft.	99 (2803 l)
Uncrated Crated Weight lbs.	320 (145 kg) 365 (166 kg)

NOTES:

1. Net Capacity cu. ft. = Half Height Door | Full Height Door models.
2. Height shown when mounted on standard 6" high casters.
3. Figure shown reflects the area of standard shelf compliance.
4. MDEC = Maximum Daily Energy Consumption
5. Based on a 90°F ambient and 20°F evaporator. For remote data please refer to spec sheet TR35837.

EQUIPMENT SPECIFICATIONS

CONSTRUCTION, HARDWARE, INSULATION

Cabinet exterior front, louver assembly and doors are constructed of stainless steel. Cabinet sides (including returns), interior and door liners are constructed of anodized aluminum. The exterior cabinet top and bottom are constructed of heavy gauge galvanized steel. A set of four (4) 6" (15 cm) high casters are included.

Doors are equipped with removable plug cylinder locks and guaranteed for life cam-lift, gravity action, self-closing metal, glide hinges with stay open feature at 120°. Hinges include a concealed switch to automatically activate the interior LED lighting.

Gasket profile and durable long life material simplify cleaning and increase overall gasket life. Anti-condensate heaters are located behind each door opening.

The cabinet is insulated with an average of 2" (5 cm) thick high density, non-CFC, foamed in place polyurethane.

SELF-CONTAINED REFRIGERATION SYSTEM

A top mounted, self-contained, refrigeration system using environmentally friendly, non-flammable R-450A refrigerant is conveniently located behind the one piece louver assembly. It features an easy to clean front facing condenser, thermostatic expansion valve, air-cooled hermetic compressor, large, high humidity evaporator coil located outside the food zone and a top mounted non-electric condensate evaporator. A 9' (2.7 m) NEMA cord and 15-5P plug is provided. Standard operating temperature is 34° to 38°F (1° to 3°C)

CONTROL

The easy to use water resistant microprocessor control system is supplied standard. It includes a 3-Digit LED Display with both a Fahrenheit or Celsius Temperature Scale Display Capability

INTERIOR ARRANGEMENTS

Standard interior arrangements include three (3) epoxy coated wire shelves per section, mounted on shelf pins, installed at the factory. Shelves are full-width, and do not have any large gaps between them requiring the use of "bridge" or "junior shelves." Recommended load limit per shelf should not exceed 225 lbs. (102kg).

DOMESTIC WARRANTY

Both a three year parts and labor warranty and a five year compressor warranty (self-contained models only) are provided standard.

OPTIONAL ACCESSORY TRAY SLIDE VERSATILITY CHART

TRAY SLIDE DRAWINGS						
TRAY SLIDE OFFERING	#1 (1) 18" x26" or (2) 14"x18"	#4 (Rod Type) (1) 18" x26"	Universal (1) 18" x26" or (2) 14"x18" or (2) 12"x20"	#1 EZ-Change (1) 18" x26" or (2) 14"x18"	Universal EZ-Change (1) 18" x26" or (2) 14"x18" or (2) 12"x20"	HD Universal EZ-Change (1) 18" x26" or (2) 14"x18" or (2) 12"x20"
SPACING CAPACITY DOOR SIZE	2" 28 Pairs Full Door & 13 Half 3" 19 Pairs Full Door & 09 Half 4" 14 Pairs Full Door & 07 Half 5" 11 Pairs Full Door & 05 Half	1 1/2" 38 Pairs Full Door (2 Pair) 1 1/2" 18 Pairs Half Door (1 Pair)	4" 14 Pairs Full Door & 06 Half 4" 14 Pairs Full Door & 07 Half 5" 11 Pairs Full Door & 05 Half 6" 09 Pairs Full Door & 04 Half	2" 26 Pairs Full Door & 12 Half 4" 13 Pairs Full Door & 06 Half	2 1/4" 22 Pairs Full Door & 11 Half 4 1/2" 11 Pairs Full Door & 05 Half	4 1/2" 11 Pairs Full Door & 05 Half 9" 05 Pairs Full Door & 02 Half

- Upper Half Height Door¹
- Lower Half Height Door²

CONTINUED PRODUCT DEVELOPMENT MAY NECESSITATE SPECIFICATION CHANGES WITHOUT NOTICE.