



Project _____
 AIA # _____ SIS # _____
 Item # _____ Quantity _____ C.S.I. Section 114000



ULT SERIES

Freezer Compact Undercounter

ULT60



STANDARD PRODUCT FEATURES

- Stainless Steel Exterior Top, Sides & Doors
- Anodized Aluminum Interior
- Front Breathing Self-Contained Refrigeration System
- Environmentally Friendly R-404A Refrigerant
- Self-Closing Stainless Steel Doors with Stay Open feature at 105 degrees
- Anodized Aluminum Interior Door Liner
- Interior Mounted Thermometer
- Two (2) Powder Coated Shelves Per Door, Mounted on Pilasters
- Automatic Non-Electric Condensate Evaporator
- Magnetic Snap-In EZ-Clean Door Gasket(s)
- 8' (2.4 m) NEMA Cord & Plug Attached
- Set of Six (6) 4" Casters
- 3-Year Parts & Labor Warranty
- 2-Years Additional Compressor Parts Warranty



Many models are ENERGY STAR® listed. Please refer to www.energystar.gov to view the most up-to-date product listing and performance data.



This unit is listed to the applicable UL, CSA and NSF Standards by an approved NRTL. Consult the factory or unit's data plate for approval information.

ACCESSORIES & OPTIONS (*field installed)

- CK21 (six 6" (15.2 cm) high casters for 60" models)
- CK25 (six 3-1/2" (8.9 cm) high casters for 60" models)
- CK27 (six 2-3/4" (6.9 cm) high casters for 60" models)
- CUACC-LEGSET6 (six 6" (15.24 cm) high legs for 60" models)
- SHELF60 UPPER (upper shelf for 60" models)
- SHELF60 LOWER (lower shelf for 60" models)
- CU60TOP-BSW0 (22 ga. stainless steel top with 4" (10.2 cm) backsplash 60")
- Optional accessory kits shipped separately for field installation

AVAILABLE CONFIGURATIONS

27" 48" 60" Wide Models

Model	Door Style	Hinging
ULT60-LR	Two Hinged Solid Doors	Left/Right
ULT60-LL	Two Hinged Solid Doors	Left/Left
ULT60-RR	Two Hinged Solid Doors	Right/Right

Factory Installed Options

Stainless Steel Finished Back * Other Door Hinging

DEALERS CHOICE COMPACT UNDERCOUNTERS

CONTINUED PRODUCT DEVELOPMENT MAY NECESSITATE SPECIFICATION CHANGES WITHOUT NOTICE.

Approved by _____ Date _____ Approved by _____ Date _____



MODELS:

ULT 60-LR, -LL, -RR

CLICK 
TRANSFER
For KCL CADalog Website

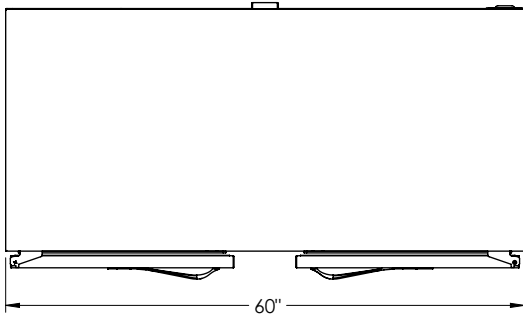

TOP VIEW

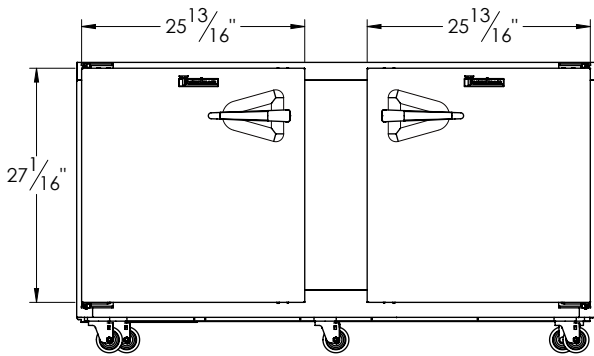
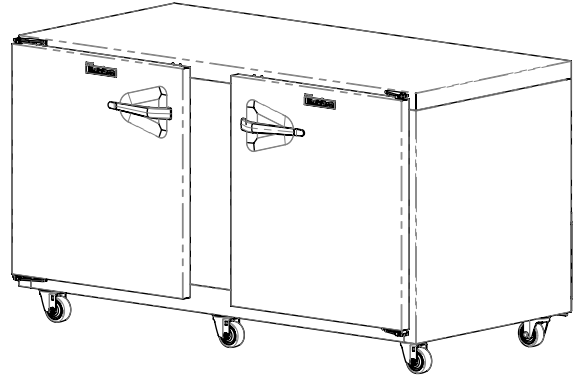

ELEVATION

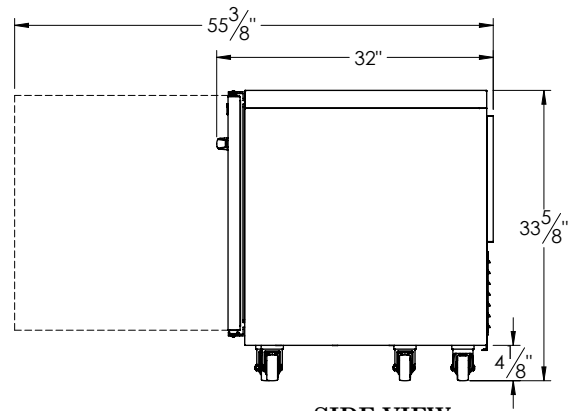

SIDE VIEW



Project _____
 AIA # _____ SIS # _____
 Item # _____ Quantity _____ C.S.I. Section 114000



ULT SERIES

Freezer Compact Undercounter Models

Door Models: ULT60-LR, -LL, -RR

EQUIPMENT SPECIFICATIONS

MODELS	ULT60-__
CABINET DIMENSIONAL DATA	
Storage cu. Ft. (l)	17.47 (494)
Width cabinet in. (cm)	60" (152)
Width - door in. (cm)	25 7/8" (65.7)
Depth - door open 90° in.	55 3/8" (140.7)
Clear door opening in. (cm)	22 3/4" (57.8)
# of doors	2
# of shelves	4
Total shelf Area sq. ft. (m)	13.2 (1.23)
ELECTRICAL DATA & REFRIGERATION DATA 115/60/1 NEMA 5-15P	
Full Load Amps	8.0
MDEC ¹ (KWH)	4.96
Refrigerant	R-404A
Refrigerant Amount oz. (gr)	16(454)
BTU ² /HR H.P.	1740 (1/2)
SHIPPING DATA	
Width Crated in. (cm)	69" (175)
Volume Crated cu. Ft. (l)	91 (2577)
Weight lbs. (kg) - Crated	457 (207)

CONSTRUCTION, HARDWARE, INSULATION

Cabinet exterior front, one piece sides, and doors are constructed of 22 gauge stainless steel. Cabinet interior and door liners are constructed of anodized aluminum. The exterior cabinet back and bottom are constructed of galvanized steel.

Door self-closes at less than 90 degrees and also includes a stay open feature at 105 degrees. Gasket profile and Santoprene® material simplify cleaning and increase overall gasket life. Both the cabinet and door(s) are insulated with an average of 2" (5 cm) thick high density, non-CFC, foamed in place polyurethane.

REFRIGERATION SYSTEM

A balanced, rear mounted, front breathing, self-contained refrigeration system using R-404A refrigerant is provided. It features a TXV valve, air cooled 1740 BTU. 1/2 hp, hermetic compressor, a forced air evaporator coil and a non-electric condensate evaporator. An 8' (2.4m) NEMA cord and plug is provided. Standard operating temperature for freezer models is 0° to -5°F (-17° to -16°C).

INTERIOR

Standard interior arrangements include two (2) powder coated wire shelves per door, mounted on pilasters. These are adjustable in 1/2" (1.27 cm) increments, allowing for a minimum of 1-1/2" (3.81 cm) spacing between shelves.

DOMESTIC WARRANTY

Both a three year parts and labor warranty and a five year compressor parts warranty (self-contained models) are provided standard.

NOTES:

- MDEC = Maximum Daily Energy Consumption
 - Compressor BTU based on a 90° F (32° C) degree ambient and 20° (-6° C) degree evaporator.
- When ordering please specify: voltage, hinging and optional accessories.

CONTINUED PRODUCT DEVELOPMENT MAY NECESSITATE SPECIFICATION CHANGES WITHOUT NOTICE.

Approved by _____ Date _____ Approved by _____ Date _____