



Project \_\_\_\_\_  
 AIA # \_\_\_\_\_ SIS # \_\_\_\_\_  
 Item # \_\_\_\_\_ Quantity \_\_\_\_\_ C.S.I. Section 114000



DEALERS CHOICE PREP TABLES

## UST SERIES

Compact Sandwich Prep Tables with Flat Cover/Self-Contained UST 32" Wide Models



## STANDARD PRODUCT FEATURES

- High Quality Stainless Steel Exterior Top, Sides & Door(s)
- Durable, Corrosion Resistant Anodized Aluminum Interior
- Provides NSF Standard 7 Performance, Even When Using 6" Deep Pans
- Standard Work Height 34-3/8" on 4" casters
- Environmentally Friendly, Non-Flammable R-450A Refrigerant
- Top Cut-Outs Accommodate Sixth Size Pans (divider bars and 4" deep plastic sixth size pans provided)
- Reinforced Pan Ledge (holds pans securely level)
- Reversible, Full Length White Nylon Cutting Board
- Self-Closing Stainless Steel Doors with Convenient Stay Open Feature at 105 Degrees
- Guaranteed for Life Workflow Handle
- Interior Mounted Thermometer
- Two (2) Powder Coated Steel Shelves Per Door, Mounted on Adjustable Pilasters
- Set of Four (4) 4" Casters
- Magnetic Snap-In EZ Clean Door Gasket(s)
- 3-Year Parts And Labor Warranty
- 2-Years Additional Compressor Parts Warranty



This unit is listed to the applicable UL, CSA and NSF Standards by an approved NRTL. Consult the factory or unit's data plate for approval information.

## AVAILABLE CONFIGURATIONS

27", 32", 48", 60" & 72" Wide Models

### Model

UST328  
UST3212

### Model Type

32" Wide 6 Pan Model  
32" Wide 9 Pan Model

## ACCESSORIES & OPTIONS (\*field installed)

- CK20 (four 6" (15.2 cm) high casters for 32" models)
- CK24 (four 3-1/2" (8.9 cm) high casters for 32" models)
- CK26 (four 2-3/4" (6.9 cm) high casters for 32" models)
- CK28 (four 2-1/2" (6.4 cm) high casters for 32" models)
- CUACC-LEGSET4 (four 6" (15.24 cm) high legs for 32" models)
- Shelf CPW2 (additional shelf for 32" models)
- Optional accessory kits shipped separately for field installation

## Factory Installed Options

Stainless Steel Finished Back \* Other Door Hinging

CONTINUED PRODUCT DEVELOPMENT MAY NECESSITATE SPECIFICATION CHANGES WITHOUT NOTICE.

Approved by \_\_\_\_\_ Date \_\_\_\_\_ Approved by \_\_\_\_\_ Date \_\_\_\_\_



MODELS:

UST328

CLICK   
**TRANSFER**  
For KCL CADalog Website

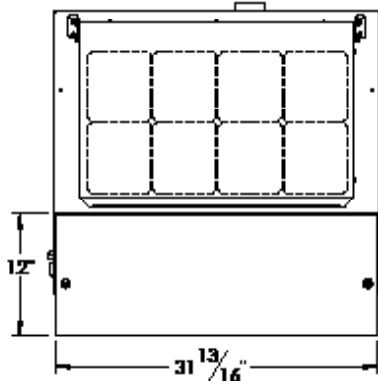

TOP VIEW

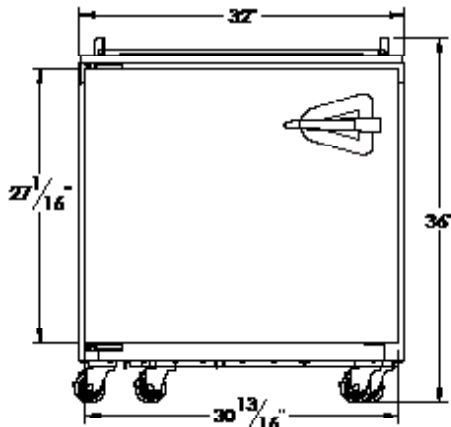
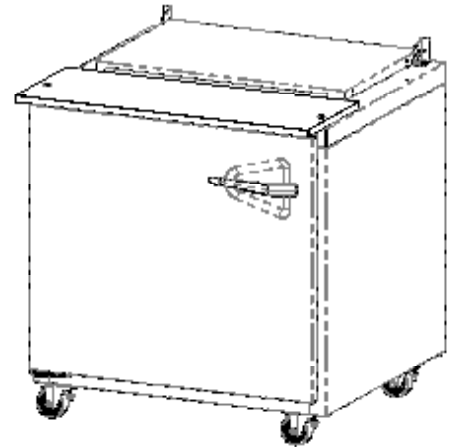

TOP VIEW

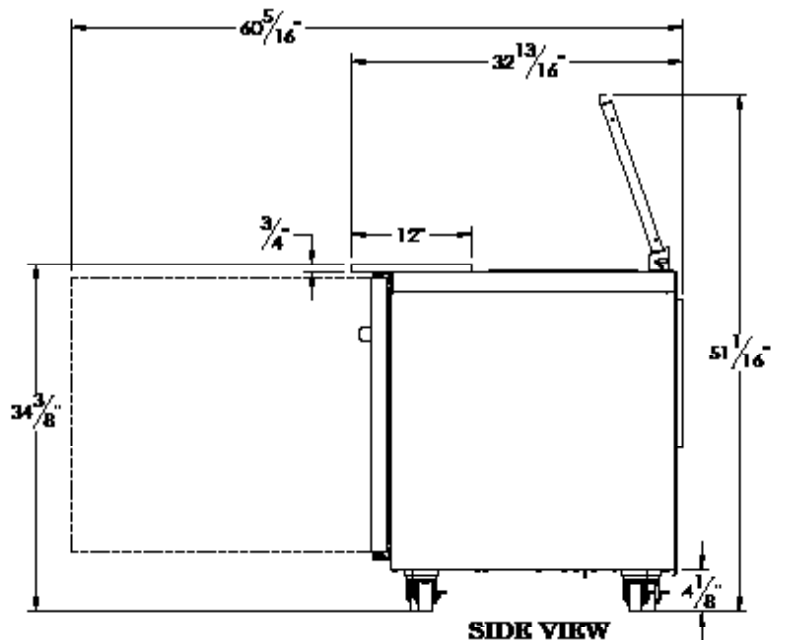

SIDE VIEW

# UST SERIES

Compact Sandwich Prep Table

## MODELS:

UST3212

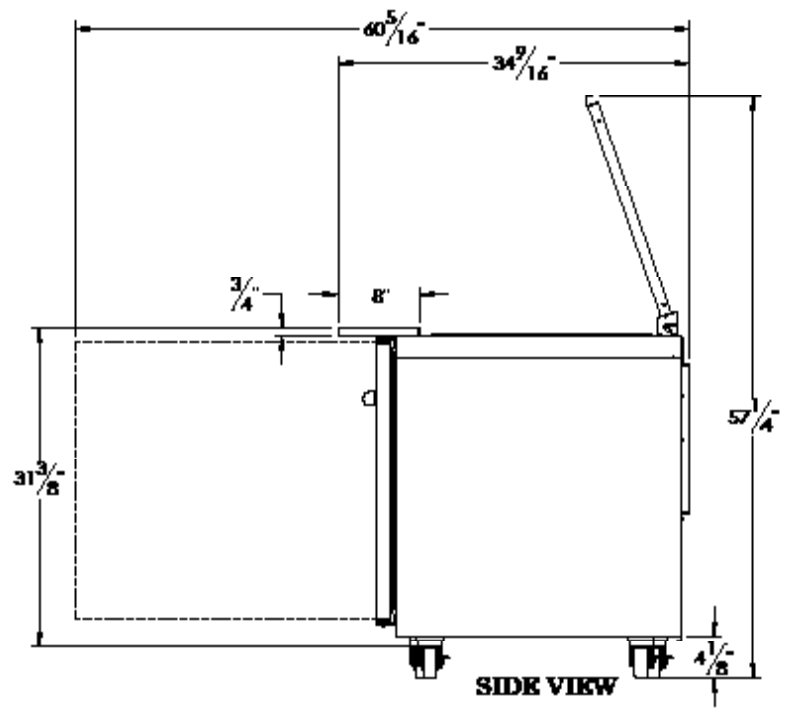
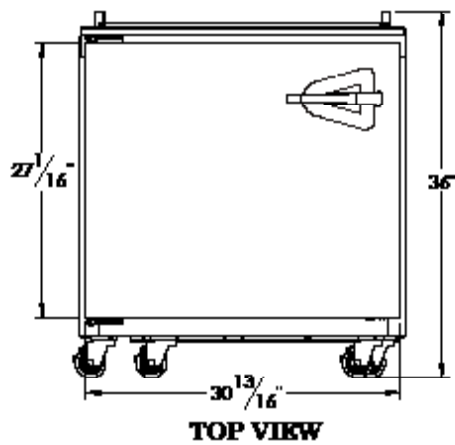
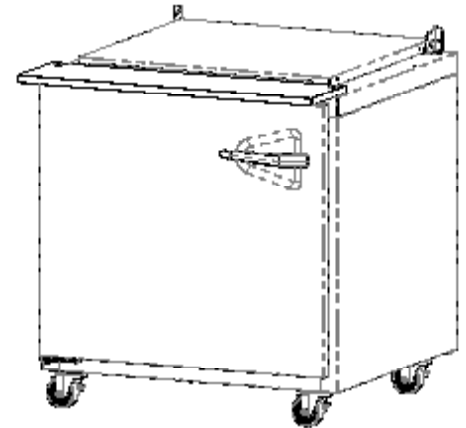
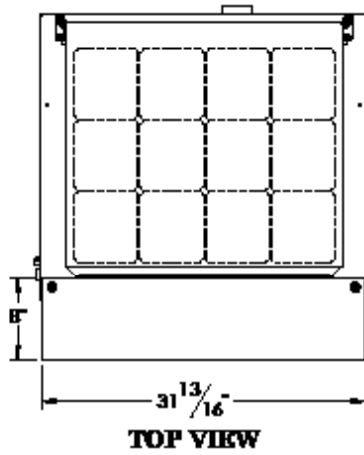



# UST SERIES

## Compact Sandwich Prep Tables Self-Contained

### MODELS

Door Models: UST328, UST3212

### EQUIPMENT SPECIFICATIONS

MODELS	UST328   UST3212
<b>CABINET DIMENSIONAL DATA</b>	
Volume	N/A
# of 1/6 Size Pan Top	8   12
Width- Cabinet	32"
Width-Door	30 13/16"
Depth-door open 90°	60 3/8"
Depth-Cutting Board	12"   8"
Height - Lid Open at 70°	17 1/2"   23 5/8"
Clear Door Opening	27 3/4"
# of Doors	1
# of Shelves	2
Total Shelf area sq. ft	6.13
<b>ELECTRICAL DATA &amp; REFRIGERATION DATA</b> 115/60/1 NEMA 5-15P	
Full Load Amps	7.5
MDEC <sup>1</sup>	N/A
Refrigerant	R-450A
Refrigerant Amt oz. (gr)	8.5 (241)
BTU/HR   H.P. <sup>2</sup>	1390 (1/4)
<b>SHIPPING DATA</b>	
Width Crated in. (cm)	45" (114)
Volume Crated cu. ft. (l)	45 (3228)
Weight lbs. (kg) - Crated	254 (115)

#### CONSTRUCTION, HARDWARE, INSULATION

Cabinet exterior front, sides, pan cover lid and doors are constructed of 22 gauge stainless steel. Cabinet interior and door liners are constructed of anodized aluminum. The exterior cabinet back at the bottom are constructed of galvanized steel.

Doors self close at less than 90 degrees and also includes a stay open feature at 105 degrees. Gasket profile and Santoprene® material simplify cleaning and increase overall gasket life.

Both the cabinet and doors are insulated with an average of 2" thick high density non-CFC, foamed in place polyurethane. A 3/4" thick, full-length, reversible white nylon cutting board is supplied standard.

#### Pans & Cover

Each model is supplied standard with its full compliment of 4" deep plastic 1/6 size pans and stainless steel pan dividers. The pan cover and lid are constructed of stainless steel, and is easily removable for cleaning.

#### REFRIGERATION SYSTEM

A balanced, rear mounted, front breathing, self-contained refrigeration system using environmentally friendly, non-flammable R-450A refrigerant is provided. It features a capillary tube metering device, air cooled hermetic compressor, a forced air evaporator coil and a non-electric condensate evaporator. An 8' cord and plug is provided. Standard operating temperature of the refrigerated base is 34° to 38°F (1.1° to 3.3°C).

#### INTERIOR

Standard interior arrangements include two (2) powder coated wire shelves per door, mounted on pilasters. These are adjustable in 1/2" (1.27 cm) increments, allowing for a minimum of 1-1/2" (3.81 cm) spacing between shelves.

#### WARRANTIES

Both a three year parts and labor warranty and a five year compressor parts warranty (self-contained models only) are provided standard.

#### NOTES:

- MDEC = Maximum Daily Energy Consumption
  - Compressor BTU based on a 90°F ambient and 20°F evaporator
- When ordering please specify: Voltage, Hinging, Optional Accessories and any additional warranties.
  - This unit may be manufactured in other electrical characteristics and may have additional regulatory agency approvals. Consult factory for other electrical characteristics and agency approvals based on specific electrical and country requirements. (For exact electricals information and approval marks, always refer to the data label of the unit.)

CONTINUED PRODUCT DEVELOPMENT MAY NECESSITATE SPECIFICATION CHANGES WITHOUT NOTICE.