

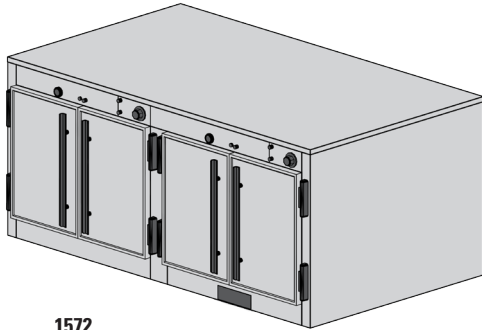

Your Solutions Partner

Specifications

F.O.B Sedalia, Missouri 65301



1572

OPTIONS:

- Enclosed base - 6" high
- Cord and plug - 8'
- Casters - 5" polyurethane, 2 swivel w/brakes 2 rigid
- Push bar
- Bumpers - stainless steel
- Door Panels - laminated plastic
- Additional pair 5" angle slides
- Door locks
- Legs
- 440-480V Circuit
- Celsius thermometer in lieu of Fahrenheit
- 208V/1Ph; 208V/3Ph; 240V/1 PH; 240/3PH

AGENCY LISTING:



DUKE MANUFACTURING CO.
2305 N. Broadway
St. Louis, MO 63102

800.735.3853 Toll Free
314.231.5074 Fax
www.dukemfg.com

Approval Stamp(s):

PRODUCT INFORMATION:

PROJECT: _____

ITEM: _____

QUANTITY: _____

MODEL:

Thermotainer Food Holding Cabinets - "D" Series 16-3/4"H x 22"W x 28-1/2" D Compartments

- 1571** Reach-In 1 thermostat per compartment , w/o legs
- 1571P** Pass-Thru 1 thermostat per compartment, w/o legs
- 1572** Reach-In 1 thermostat per compartments , w/o legs
- 1572P** Pass-Thru 1 thermostat per compartments, w/o legs

BODY:

- Heavy gauge stainless steel, all panels except bottom
- Shell welded to interior
- Die-stamped compartment openings

DOORS:

- Stainless steel Uni-Door construction
- Operate simultaneously, either opening or closing
- Overhead operating unit
- Automatic stop holds open position
- Spring hinges die-stamped, with built-in-stop externally adjustable, completely concealed

COMPARTMENT:

- Heavy gauge stainless steel
- Rounded corners
- Stainless steel studs for angle slides at 3 levels
- (3) removable, adjustable, stainless steel, 5" angled slide pairs
- Removable liner for inspection and maintenance

ELECTRICAL CONTROLS:

- Recessed thermostat w/built-in On-Off switch
- Heat range 100° - 300° and dial thermometer
- Pilot lights
- Recessed connection box
- Thermostat, pilot lights set in removable access panel

DAMPERS:

- 2-position sliding type
- Controlled by push buttons
- Compartments individually controlled

INSULATION:

- Body fully insulated with 1-1/2" fiberglass, doors with fiberglass.

HEATING ELEMENTS:

- Sheath type strip heaters, 120 Volt, 1 Phase
- Removable compartment for ease of access to heating element.

SHORT FORM SPECIFICATIONS:

Duke Thermotainers Food Holding Cabinets. Models 1571/1571P constructed with one (1) compartments. Models 1572/1572P to have two (2) compartments. Compartments 16-3/4"H x 22"W x 28-1/2"D. Each compartment to have three (3) pairs of removable stainless steel slides. One thermostat per compartment. 100° - 300°F heat range with dial thermometer. Built-in installation - allow 1/4" tolerance greater than body width.



**THERMOTAINER FOOD HOLDING CABINETS - "D" SERIES
16-3/4" H x 22" W x 28-1/2" D COMPARTMENTS**

- 1571** Reach-In 1 thermostat per compartments, w/o legs
- 1571P** Pass-Thru 1 thermostat per compartments, w/o legs
- 1572** Reach-In 1 thermostat per compartments, w/o legs
- 1572P** Pass-Thru 1 thermostat per compartments, w/o legs

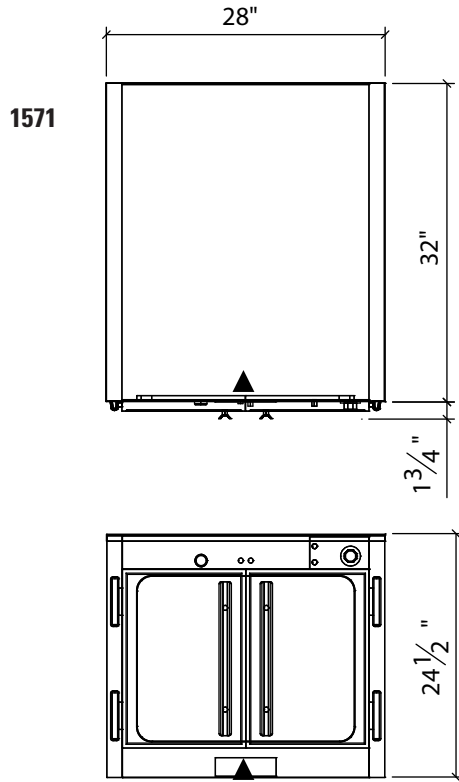

LEGEND	
	- ELECTRICAL CONNECTION

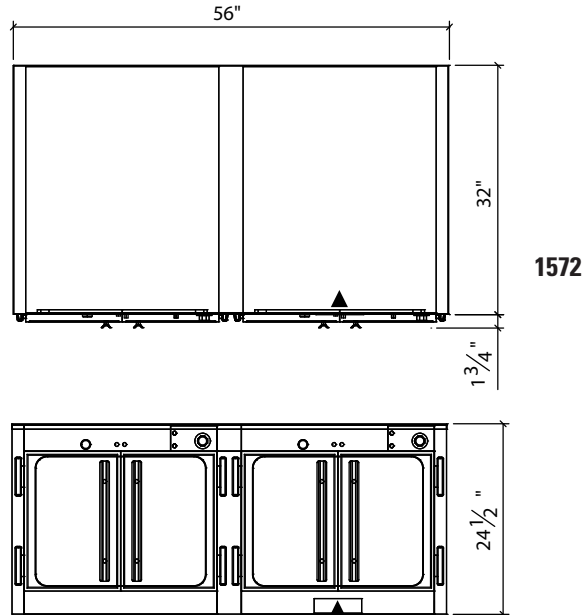

DIMENSIONS:

FREIGHT CLASS: 100

Model	Width		Depth		Height		Comp. Depth		Cube ft. crated	Weight	
	in	cm	in	cm	in	cm	in	cm		lbs	kg
1571	28	71.1	33-3/4	85.7	24-1/2	62.2	28-1/2	72.4	28.6	250	113.6
1571P	28	71.1	35-1/2	90.2	24-1/2	62.2	30-1/2	77.5	29.9	250	113.6
1572	56	142.2	33-3/4	85.7	24-1/2	62.2	28-1/2	72.4	52.2	550	250.0
1572P	56	142.2	35-1/2	90.2	24-1/2	62.2	30-1/2	77.5	54.6	550	250.0

ELECTRICAL SPECIFICATIONS: (Consult factory for 3-phase electrical requirements and other options.) 120V, 1Ph

Model	Connected Load
1571	1000 watts
1571P	1000 watts
1572	2000 watts
1572P	2000 watts

	1571/1571P	1572/1572P
Capacity w/standard slides	(10) 12" x 20" x 2" pans or (6) 12" x 20" x 4" pans or (4) 12" x 20" x 8" pans (7) 18" x 26" bake sheets	(20) 12" x 20" x 2" pans or (12) 12" x 20" x 4" pans or (8) 12" x 20" x 8" pans (14) 18" x 26" bake sheets

- 1571** Reach In - hinged doors on front only
- 1571P** Pass Thru - hinged doors on front & back for pass-thru service
- 1572** Reach In - hinged doors on front only
- 1572P** Pass Thru - hinged doors on front & back for pass-thru service



DUKE MANUFACTURING CO.

2305 N. Broadway
St. Louis, MO 63102

800.735.3853 Toll Free
314.231.1130 In Missouri
314.231.5074 Fax
www.dukemfg.com

Specification subject to change