



Your Solutions Partner

# Specifications

F.O.B Sedalia, Missouri 65301



2454



2456

### OPTIONS:

- Enclosed base - 6" high
- Cord and plug - 8'
- Casters - 5" polyurethane, 2 swivel w/brakes 2 rigid
- Push bar
- Bumpers - stainless steel
- Door Panels - laminated plastic
- Additional pair 5" angle slides
- Door locks
- 440-480V Circuit
- Celsius thermometer in lieu of Fahrenheit
- 208V/1Ph; 208V/3Ph; 240V/1 PH; 240/3PH

### AGENCY LISTING:



**DUKE MANUFACTURING CO.**  
 2305 N. Broadway  
 St. Louis, MO 63102

**800.735.3853 Toll Free**  
**314.231.5074 Fax**  
**www.dukemfg.com**

SS-DM-00207-THM-34

### Approval Stamp(s):

### PRODUCT INFORMATION:

PROJECT: \_\_\_\_\_

ITEM: \_\_\_\_\_

QUANTITY: \_\_\_\_\_

MODEL:

### Thermotainer Food Holding Cabinets - "B" Series 9"H x 22"W x 28-1/2" D Compartments

- 2454** Reach-In 1 thermostat per compartment , w/ legs
- 2454P** Pass-Thru 1 thermostat per compartment , w/ legs
- 2456** Reach-In 1 thermostat per compartment , w/ legs
- 2456P** Pass-Thru 1 thermostat per compartment , w/ legs

### BODY:

- Heavy gauge stainless steel, all panels except bottom
- Shell welded to interior
- Die-stamped compartment openings

### DOORS:

- Stainless steel, die-stamped, embossed front
- Ribbed Interior
- Reinforced for mounting hardware
- Insulated with fiberglass
- Spring hinges die-stamped, with built-in-stop externally adjustable, completely concealed

### COMPARTMENT:

- Heavy gauge stainless steel
- Rounded corners
- Stainless steel studs for angle slides at 3 levels
- (2) removable, adjustable, stainless steel, 5" angled slide pairs
- Removable liner for inspection and maintenance

### ELECTRICAL CONTROLS:

- Recessed thermostat w/built-in On-Off switch
- Heat range 100° - 300° and dial thermometer
- Pilot lights
- Recessed connection box
- Removable access panel

### DAMPERS:

- 2-position sliding type
- Controlled by push buttons
- Compartments individually controlled

### INSULATION:

- Body fully insulated with 1-1/2" fiberglass

### HEATING ELEMENTS:

- Sheath type strip heaters, 120 Volt, 1 Phase
- Removable compartment for ease of access to heating elements.

### LEGS:

- Stainless steel die-stamped adjustable - 6" high

### SHORT FORM SPECIFICATIONS:

**Duke Thermotainers Food Holding Cabinets.** Models 2454/2454P constructed with four (4) compartments. Models 2456/2456P to have six (6) compartments. Compartments 9"H x 22"W x 28-1/2"D. Each compartment to have two (2) pairs of removable stainless steel slides. One thermostat per compartment on all units. 100° - 300°F heat range with dial thermometer. Built-in installation - allow 1/4" tolerance greater than body width.



**THERMOTAINER FOOD HOLDING CABINETS - "B" SERIES  
9"H x 22"W x 28-1/2"D COMPARTMENTS**

- 2454** Reach-In 1 thermostat per compartment, w/ legs
- 2454P** Pass-Thru 1 thermostat per compartment, w/ legs
- 2456** Reach-In 1 thermostat per compartment, w/ legs
- 2456P** Pass-Thru 1 thermostat per compartment, w/ legs

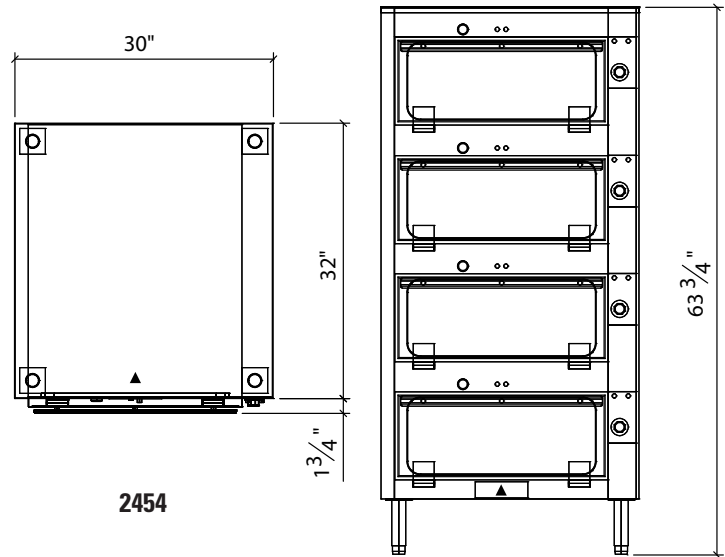
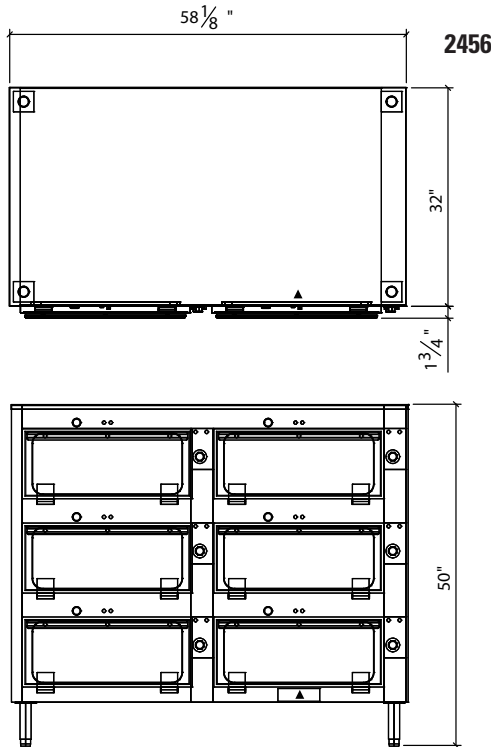

**DIMENSIONS:**

Freight Class: 100

Model	Width		Depth		Height		Comp. Depth		Cube ft. Crated	Weight	
	in	cm	in	cm	in	cm	in	cm		lbs	kg
<b>2454</b>	30	76.2	33-3/4	85.7	63-3/4	161.9	28-1/2	72.4	56.4	600	272.7
<b>2454P</b>	30	76.2	35-1/2	90.2	63-3/4	161.9	30-1/2	77.5	59.0	600	272.7
<b>2456</b>	58-1/8	147.7	33-3/4	85.7	50	127.0	28-1/2	72.4	81.3	900	409.1
<b>2456P</b>	58-1/8	147.7	35-1/2	90.2	50	127.0	30-1/2	77.5	85.0	900	409.1

**ELECTRICAL SPECIFICATIONS:** (Consult factory for 3-phase electrical requirements and other options.) 120V, 1Ph

Model	Connected Load
<b>2454</b>	3000 watts
<b>2454P</b>	3000 watts
<b>2456</b>	4500 watts
<b>2456P</b>	4500 watts

	<b>2454/2454P</b>	<b>2456/2456P</b>
<b>Capacity w/standard slides</b>	(24) 12" x 20" x 2" pans or (16) 12" x 20" x 4" pans or (8) 12" x 20" x 8" pans (12) 18" x 26" bake sheets	(36) 12" x 20" x 2" pans or (24) 12" x 20" x 4" pans or (12) 12" x 20" x 8" pans (18) 18" x 26" bake sheets

- 2454** Reach In - hinged doors on front only
- 2454P** Pass Thru - hinged doors on front & back for pass-thru service
- 2456** Reach In - hinged doors on front only
- 2456P** Pass Thru - hinged doors on front & back for pass-thru service



**DUKE MANUFACTURING CO.**

2305 N. Broadway  
St. Louis, MO 63102

800.735.3853 Toll Free  
314.231.1130 In Missouri  
314.231.5074 Fax  
www.dukemfg.com

Specification subject to change