



"Your Solutions Partner"

Specifications

F.O.B Sedalia, Missouri 65301



313-25
Shown with optional 3 bar tray slide

OPTIONS:

- Sliding doors - **A328-xPG/xSS**
- Door locks
- Serving shelves w/glass protector panels - **A956-460 - x**
- Glass display shelves - **A98x**
- Self Service Canopies - **TS530-xx, TS530-xx-1SN**
- Buffet shelves - **A83x/A93x**
- Adapter bars - **A513, A515, A516**
- Adapter panels - **A, B, C, D, E, F, G, H**
- Stainless steel carving boards - **A442-x-S/A445-xS**
- Wood carving boards - **A442-xW/A445-xW**
- Solid tray slides - **ASOLID - FX/HD**
- 3 bar tray slides
- Kick plates
- 5" casters, 2 swivel w/locks - **AACA-SW**
- Die stamped openings - 12" x 20" (Hot Food Style Top) - **AHFST**
- Stainless steel dish shelf - **A441-xS**
- Drop brackets on tray slide - **AHD-BRKT-3BTS**
- False bottom - perforated, stainless - **ACMOD-5, -6, -7**
- 8" deep liner
- Open base - omit undershelves
- Veneered plastic laminate panels on body
- Special powder coat painted body
- Body latches - **14695**

AGENCY LISTINGS:



DUKE MANUFACTURING CO.
2305 N. Broadway
St. Louis, MO 63102

800.735.3853 Toll Free
314-231-1130 In Missouri
314.231.5074 Fax
www.dukemfg.com

Approval Stamp(s):

PRODUCT INFORMATION:

PROJECT: _____
ITEM: _____
QUANTITY: _____

MODEL:

AeroServ Serving Systems Cold Pan Units - Ice Cooled

- 313-25** 46" length unit/40" length top surface
- 314-25** 60" length unit/54" length top surface
- 325-25** 74" length unit/68" length top surface

TOP:

- 20 gauge, 300 Series stainless steel
- Cut-out, flanged down and attached to perimeter trough

LINER:

- 18 gauge, 300 Series stainless steel - 5" deep
- Insulated on all four sides and bottom
- 1" cast brass drain and plug

BODY:

- Paint grip or stainless steel
- Choice of (12) powder coat paint colors (must choose one)
 - #217105 - Designer White
 - #217150 - Orange
 - #217107 - Hollyberry Red
 - #217127 - Fence Green
 - #217102 - Silver Hammer
 - #217101 - Semi-Gloss Black
 - #217103 - Natural Almond
 - #217154 - Racing Red
 - #217120 - Sky Blue
 - #217152 - Stone Gray
 - #217113 - Brown Kickplate
 - #217125 - Textured Black
- Flanged or channeled edges
- Welded together with local reinforcements
- Mounted on 6" stainless steel legs with adjustable feet

SHORT FORM SPECIFICATIONS:

Duke AeroServ Serving Systems - Cold Pan Units - Ice Cooled - Top shall be constructed of 20 gauge, 300 Series stainless steel, flanged down into heavy gauge, 300 Series stainless steel ice pan, 5" deep. Ice pan shall be 19-7/8"W x 6" shorter than length of top, insulated on all four sides and bottom and equipped with 1" cast brass drain and plug. Unit to have intermediate shelf. Body and shelves shall be formed of paint-grip steel with powder coat paint or stainless steel with integrally flanged or channeled edges for rigidity and structural strength. Each body individually welded together with local reinforcements as required. 6" polished stainless steel legs to be furnished. Must add "PG" to model number for Paint Grip Bodies, "SS" for Stainless steel bodies.

ASC-05

AEROSERV - SERVING SYSTEMS - COLD PAN UNITS - ICE COOLED

Catalog No. ASC-ICE

A.I.A. File No. 35-C-13



AEROSERV SERVING SYSTEMS

Cold Pan Units - Ice Cooled

- 313-25 46" length unit / 40" length surface
- 314-25 60" length unit / 60" length surface
- 325-25 74" length unit / 68" length surface

LEGEND	
	DRAIN LOCATION

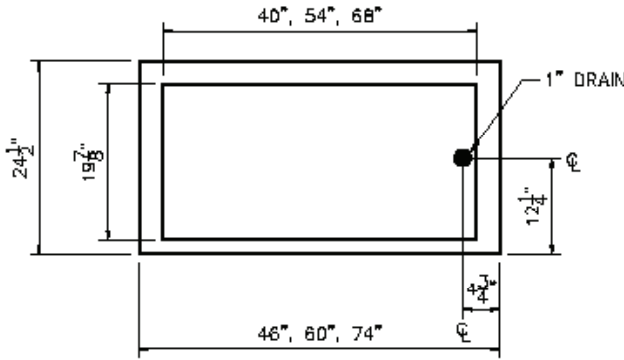

TOP VIEW

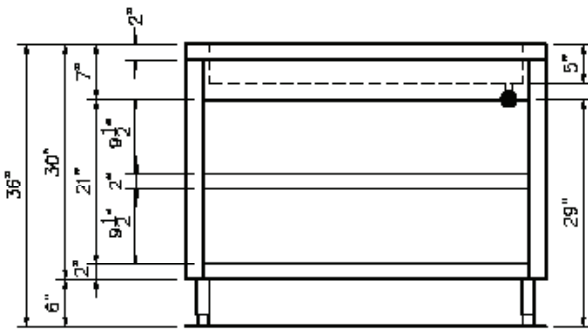

FRONT VIEW

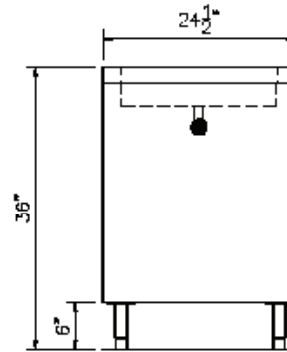

RIGHT SIDE VIEW

DIMENSIONS:

FREIGHT CLASS: 150

Model	Depth		Width		Height		Cube ft. crated	Weight		Cold Pan Length	
	in	cm	in.	cm	in.	cm		lbs	kg	in.	cm
313-25	46	116.8	24-1/2	62.2	36	91.4	37.7	220	100.0	40	101.6
314-25	60	152.4	24-1/2	62.2	36	91.4	47.9	284	129.1	54	137.2
325-25	74	188.0	24-1/2	62.2	36	91.4	58.1	349	158.6	68	172.7



"Your Solutions Partner"

DUKE MANUFACTURING CO.
 2305 N. Broadway
 St. Louis, MO 63102

800.735.3853 Toll Free
 314.231.5074 Fax
 www.dukemfg.com

Specification subject to change

06/08
 Printed in U.S.A.
 © 2008, Duke Manufacturing Co.