



Your Solutions Partner

Specifications

F.O.B Sedalia, Missouri 65301



OPTIONS:

- Condensate Evaporator - **COND-EVAP**
- 220V - 50Hz compressor
- Remote installation of compressor
- False Bottom
- Stainless steel louvered grille
- Designer Foodshields
- Stainless steel adapter panels
- Adapter bars

AGENCY LISTING:



DUKE MANUFACTURING CO.
2305 N. Broadway
St. Louis, MO 63102

800.735.3853 Toll Free
314.231.5074 Fax
www.dukemfg.com

SS-DM-00108-ADI-05

Approval Stamp(s):

PRODUCT INFORMATION:

PROJECT: _____

ITEM: _____

QUANTITY: _____

MODEL:

Drop-Ins - Cold Pan Mechanical - 8" Deep Liner Meets NSF Standard 7

- ADI-1M-N7** (1) 4" Deep 12" x 20" pan
- ADI-2M-N7** (2) 4" Deep 12" x 20" pan
- ADI-3M-N7** (3) 4" Deep 12" x 20" pan
- ADI-4M-N7** (4) 4" Deep 12" x 20" pan
- ADI-5M-N7** (5) 4" Deep 12" x 20" pan
- ADI-6M-N7** (6) 4" Deep 12" x 20" pan

TOP RIM:

- Heavy gauge, 300 Series stainless steel
- Overhang on front, back and ends w/locking tabs
- Vinyl foam gasket as sealant
- 300 Series stainless steel cold pan liner
- Product recessed 3" below top
- Insulated all four sides and bottom
- 1" cast brass drain and plug
- Adapter bars furnished for full size pans
- Removable stainless brackets 3" below top

REFRIGERATION:

- Copper coils attached to all sides of liner - R134A refrigerant
- Open angle-iron suspended compressor compartment
- Remote mounted on/off switch with stainless steel face plate
- 120V condensing unit
- 6' cord and plug - NEMA 5-15
- Five year warranty on compressor motor

EXTERIOR HOUSING

- Heavy gauge paint grip steel

SHORT FORM SPECIFICATIONS:

Duke Drop-Ins - Cold Pan - Mechanical - 8" Deep - Meets NSF Standard 7. Top flange of heavy gauge 300 series s/s with overhang on 4 sides, refrigerated cold pan, s/s top and interior liner, heavy gauge paint grip steel exterior housing, with drain, remote mounted on/off switch, 8" deep liner, cord and plug, adapter bars for full size pans furnished. Note: Do not fully enclose compressor area. Two unrestricted openings of no less than 200 sq. inches required in cabinet for proper cooling, NSF-7

DROP-IN - COLD PAN - MECHANICAL - 8" DEEP - N7

Catalog No. ADI-MECH8N7

A.I.A. File No. 35-C-13

REV A

Duke®

Drop-Ins - Cold Pan Mechanical - 8" Deep Liner Meets NSF Standard 7

- ADI-1M-N7** (1) 4" Deep 12" x 20" pan
- ADI-2M-N7** (2) 4" Deep 12" x 20" pan
- ADI-3M-N7** (3) 4" Deep 12" x 20" pan
- ADI-4M-N7** (4) 4" Deep 12" x 20" pan
- ADI-5M-N7** (5) 4" Deep 12" x 20" pan
- ADI-6M-N7** (6) 4" Deep 12" x 20" pan

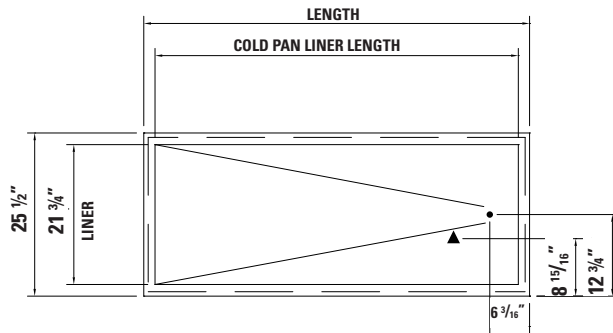

ADI-4M-N7 UNIT SHOWN

TOP VIEW

LEGEND	
▲	ELECTRICAL CONNECTION
●	DRAIN LOCATION

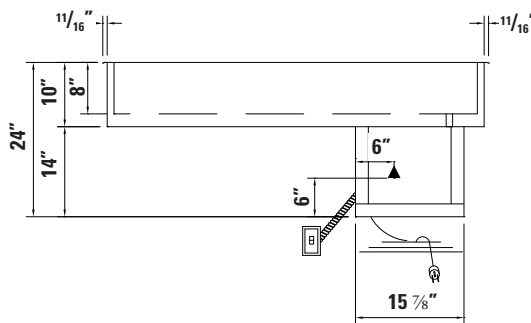

FRONT VIEW

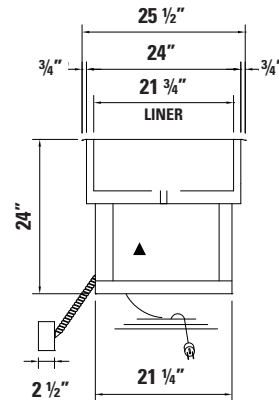

RIGHT SIDE VIEW

DIMENSIONS - Liners are 21-3/4" (55.3 cm) W; cutouts 24-3/4" (62.3cm) W

FREIGHT CLASS: 100

Model	Length		Width		Height		Cube ft crated	Adapter Bars	Weight		Cold Pan - L		Cutout - L	
	in.	cm	in	cm	in	cm			lbs	kg	in.	cm	in.	cm
ADI-1M-N7	18 7/8	45.7	25 1/2	64.8	24	61.0	13.2	0	150	68.2	14 1/2	36.8	17 1/2	44.5
ADI-2M-N7	32 7/8	81.3	25 1/2	64.8	24	61.0	20.8	1	160	72.3	28 1/2	72.4	31 1/2	80.0
ADI-3M-N7	46 7/8	116.8	25 1/2	64.8	24	61.0	28.5	2	175	90.9	42 1/2	108.0	45 1/2	115.6
ADI-4M-N7	60 7/8	152.4	25 1/2	68.4	24	61.0	36.1	3	200	113.6	56 1/2	143.5	59 1/2	151.1
ADI-5M-N7	74 7/8	188.0	25 1/2	68.4	24	61.0	46.8	4	230	138.6	70 1/2	179.1	73 1/2	186.7
ADI-6M-N7	88 7/8	223.5	25 1/2	68.4	24	61.0	51.4	5	280	159.1	84 1/2	214.6	87 1/2	222.3

24 REMOTE CONTROL CUTOUT IS 4-1/8" H X 2-3/16" W

ELECTRICAL SPECIFICATIONS:

Model	120 Volt	
	Amps	HP
ADI-1M-N7	4.2	1/5
ADI-2M-N7	4.2	1/5
ADI-3M-N7	4.2	1/4
ADI-4M-N7	5.2	1/4
ADI-5M-N7	6.0	1/3
ADI-6M-N7	6.0	1/3



DUKE MANUFACTURING CO.
 2305 N. Broadway
 St. Louis, MO 63102
 800.735.3853 Toll Free
 800.231.1130 In Missouri
 314.231.5074 Fax
 www.dukemfg.com

Specification subject to change