

# CONTINUOUS FLOW FROZEN CUSTARD MACHINE

CC303



- Quick-Freeze Technology minimizes size of ice crystals to ensure smoother, creamier product.
- Hold cycle keeps barrels at a safe temperature during off-cycle periods.
- Easy to clean design ensures sanitary operation and ensures product is always fresh.
- Refrigerated hopper with independent temperature control maintains safe storage temperatures in any environment.
- Delrin food grade plastic blades provide quiet operation and superior durability.
- Standard dipper well keeps scoops and spades clean.
- Highest production model (per barrel) without sacrificing the quality of product.
- Continuous feed system provides high-speed production with low overrun.
- Service panel provides easy access to temperature controls.
- Optional dual temperature control switch allows for production of various types of frozen treats, such as Italian ice, sorbet, and frozen custard.
- Optional hopper rinse faucet.



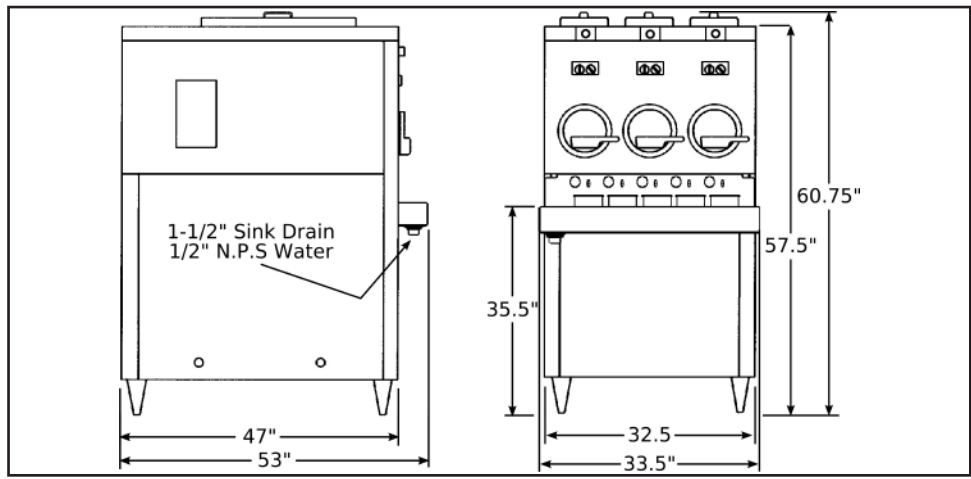

	CC303 Air Cooled		CC303 Water Cooled	
Dimensions	Freezer	with crate	Freezer	with crate
width	32" (81,3 cm)	44-1/2" (113,0 cm)	32" (81,3 cm)	44-1/2" (113,0 cm)
height	61-1/2" (156,2 cm)	67" (170,2 cm)	61-1/2" (156,2 cm)	67" (170,2 cm)
depth	47" (119,4 cm)	60" (152,4 cm)	47" (119,4 cm)	60" (152,4 cm)
Weight	905 lbs (410,5 kg)	1205 lbs (546,5 kg)	1206 lbs (547,0 kg)	1506 lbs (683,1 kg)
Electrical	1 Phase, 208-230 VAC, 60Hz		1 Phase, 208-230 VAC, 60Hz	
circuit ampacity	24A minimum		25A minimum	
overcurrent protection device	30A maximum		37A maximum	
Hopper Condenser	1 Phase, 115 VAC, 60Hz NEMA5-15P power cord provided			
Drive Motor	Three - 3 hp			
Cooling	Air cooled units require a remote condenser and approximately 24 lbs of R-404A (depending on line set length) per barrel.		Water cooled units are self contained and require a Standard Hose Adapter water fitting and a 5/8" OD drain fitting for each barrel. They are charged with R-404A.	
Hopper Volume	Three - 7.5 gallon (28,40 liters)			
Warranty	Two-year warranty on compressor, evaporator assembly, drive motor and auger. One-year warranty on remaining parts and labor.			

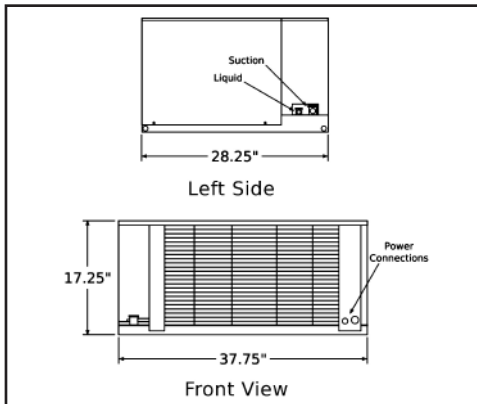

	Remote Condenser
Dimensions	Condenser
width	37-3/4" (95,9 cm)
height	17-1/4" (43,7 cm)
depth	28-1/4" (71,7 cm)
Weight	222 lbs (100,7 kg)
Electrical	3 Phase, 208-230 VAC, 60Hz
Refrigerated Line Sizes	Liquid Line - 3/8" Suction Line - 7/8"

Continuous research leads to ongoing product improvements; therefore, these specifications are subject to change without notice.

Distributed by:



**FOODSERVICE EQUIPMENT**  
 502 Highway 67 • Kiel, WI 53042-1600  
 920-894-2293 • 800-558-5807  
 Fax: 920-894-7029  
 E-mail: [foodservice@stoelting.com](mailto:foodservice@stoelting.com)  
[www.stoeltingfoodservice.com](http://www.stoeltingfoodservice.com)

ISO 9001:2000 Registered

Certified, Listed and/or Recognized by:

