



**GOLD MEDAL® PRODUCTS CO.**

# Karmel King

Model No. 2620

## Specifications

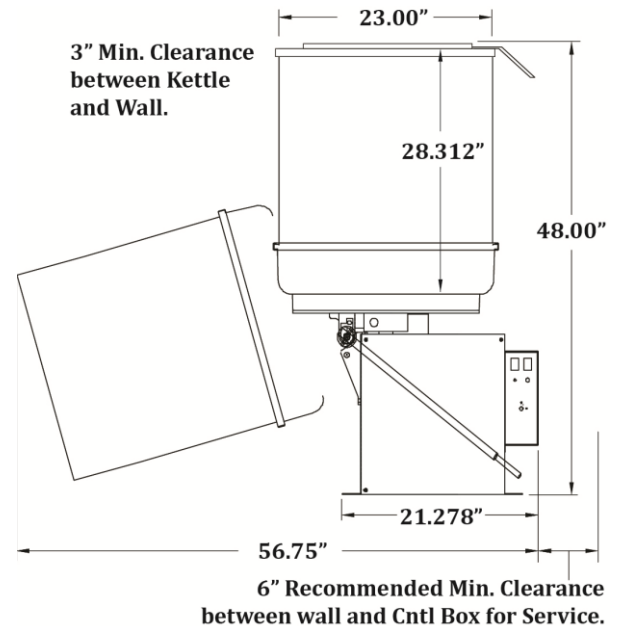

General RH Unit shown above for dim. reference.

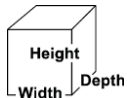

### Overall Dimensions:

**Width:** 56.75"

**Depth:** 24.25"

**Height:** 48"

Reference drawing shown for additional dimensions and clearances required.

### Electrical - Domestic

240V

6768 WATTS 60 Hz

(NEMA 6-50P) Plug

Unit designed to operate on single phase, 50 AMP, 2 wire plus ground. Wall receptacle is supplied with unit.

### Features:

- 20 Gallon Capacity (3-4 batches/hour)
- Right Hand Dump
- Electronic Temperature Control
- Cast Aluminum Kettle with Stainless Steel Drum

**Plug Type:**



NEMA 6-50P

**Agency Approvals:**



**Gold Medal Products Co.**

10700 Medallion Drive, Cincinnati, OH 45241

Ph: (513) 769-7676, (800) 543-0862; Fax: (513) 769-8500

gmpopcorn.com info@gmpopcorn.com

Warranty shall be limited to the repair or replacement of any defective part for a period of six (6) months from the date of sale to the original purchaser with regard to labor and two (2) years with regard to parts and does not cover damage to the equipment caused by accident, alteration, improper use, voltage, abuse, or failure to follow instructions. See official warranty for complete details.