

G**UNIVERSE PLUS
GAS TILTING SKILLET**

JOB NAME: _____

ITEM NO.: _____

NO. REQUIRED: _____

MODELS

- 30P-STGL** - 30 gallon (114 liter), open leg base skillet
- 30P-STGM** - 30 gallon (114 liter), closed base skillet
- 40P-STGL** - 40 gallon (152 liter), open leg base skillet
- 40P-STGM** - 40 gallon (152 liter), closed base skillet

DESCRIPTION

The Market Forge gas Universe Plus tilting skillets are available in 30-gallon (114-liter) and 40-gallon (152-liter) pan capacities with 93,000 BTU and 126,000 BTU inputs respectively. Both models are available in open-leg and closed-base frame assemblies with manual or power tilt capabilities. Pan is formed from 10 gauge type 304 stainless steel with a #4 finish exterior and polished interior with coved corners for ease of cleaning. Cooking surface shall be of 3/4" triple-ply construction with 3/8" thick aluminum core ensuring even heat distribution over entire cooking surface. The pan shall be heated with stainless steel atmospheric burners with intermittent pilot ignition. The balanced design of the pan allows the operator to easily and quickly tilt to the desired position. Units are equipped with (4) 6" (152mm) stainless steel adjustable flanged feet as standard. The optional power tilt operates smoothly, with manual override that works easily when needed and without the use of tools or drills as required by other manufactures.

CONSTRUCTION

The Universe Plus skillet has a fully polished stainless steel cooking surface that reduces food from adhering and helps to safely clean the equipment. Gas burners turn off automatically when the cooking pan is tilted from the horizontal position. The skillet is provided with a heavy-duty spring assisted cover and a condensate vent. The cooking pan and cover are supported by two consoles with a fully welded stainless steel tubular frame system that provides stable support to the unit.

The consoles are completely covered with stainless steel that provides protection to the controls and is also easily cleanable and provides clear access for easy floor cleaning. The closed-base model incorporates an easily removable stainless steel front panel. The sloped front of the pan allows for complete draining of the pan when tilted to 70°. The tilting mechanism includes a precision ground and polished worm for smooth and long lasting tilt operation and positive control with a collapsible hand crank. A power tilting option is available and is also supplied with the collapsible handle for manual override operation if required.



30P-STGM shown



30P-STGL shown

SHIPPING WEIGHT

- **30P-STGL** - 535 lbs (243 kg)
- **30P-STGM** - 565 lbs (256 kg)
- **40P-STGL** - 695 lbs (315 kg)
- **40P-STGM** - 725 lbs (329 kg)

OPTIONS & ACCESSORIES

(at additional charge)

■ **Pantry Faucets**

- Single Pantry Faucet
- Double Pantry Faucet
- Single Pantry Spray Hose
- Double Pantry Spray Hose
- Single Pantry Faucet / with 60" Spray Hose
- Double Pantry Faucet / with 60" Spray Hose

■ **Tangent Draw-Offs**

- 2" Draw-Off Valve w/Strainer
- 2" Tangent Draw-Off Valve w/ Drain Hose Assembly

- Power Tilt
- Pan Support
- Pan Holder Inserts
- Pouring Lip Strainer
- Caster Kit w/Strain Relief
- Prison package, includes lockable stainless steel hinged control cover, tamper proof screws
- Drain Cup Assembly
- Pull-Out Sliding Sink Drain Draw with Splash Shield for Open Leg Skillets

FOOD SERVICE EQUIPMENT
 Universe Plus Tilting Skillet
**MARKET FORGE**

G**UNIVERSE PLUS
GAS TILTING SKILLET**

DETAILS & DIMENSIONS

TECHNICAL SPECIFICATIONS

COOKING PAN: The polished cooking surface resists product adherence and improves cleanup and appearance. The pan incorporates an easy-pour lip and 5-gallon increment markings. An interlock switch is provided to turn the burners off when the pan is tilted more than 10° from the normal horizontal position. The spring assisted cover with integral vent, condensate drip guide and full width handle affords effortless operation and will maintain an open position.

CONTROLS: The skillet comes standard with a solid-state temperature control with a positive OFF position and 100-450°F scale, a pilot light to indicate when the elements are ON, and a 1 hour mechanical timer. The optional power tilting mechanism also utilizes an UP/DOWN rocker switch. The manual tilting mechanism uses a collapsible hand crank conveniently located below the control panel. The controls are resistant to dripping and light splashing water (NEMA T-2).

GAS SUPPLY

| Model | kW/Hr | BTU/Hr | Supply Pressure (W.C.) | |
|-----------|-------|---------|------------------------|------------------------|
| | | | Natural | Propane |
| 30 gallon | 27.2 | 93,000 | 7"-14" (178-356mm) | 11"-14" (279-356mm) |
| 40 gallon | 36.9 | 126,000 | | |

SERVICE CONNECTIONS

| | |
|------------------|---|
| G | Gas Connection - Supplied through 3/4" NPT pipe. A gas shut-off valve must be installed in supply piping convenient and adjacent to appliance. |
| E | Electrical Connection - 120V units supplied with 8' cord with 3 prong plug. Total Amps: 3 |
| C & H | Cold/Hot Water - 3/8" O.D. NPT (Optional faucet) |
| D | Drain - 1-1/2" drain NPT (Optional drain pan assembly) |

DIMENSIONS

| Model | A | B | C | D | E |
|-----------|-----------|--------------|-------------|-------------|----------|
| 30 gallon | 36 [914] | 32.63 [829] | 27.88 [708] | 25.75 [654] | 18 [457] |
| 40 gallon | 46 [1168] | 42.63 [1083] | 37.88 [962] | 25.75 [654] | 23 [584] |

FOOD SERVICE EQUIPMENT
Universe Plus Tilting Skillet

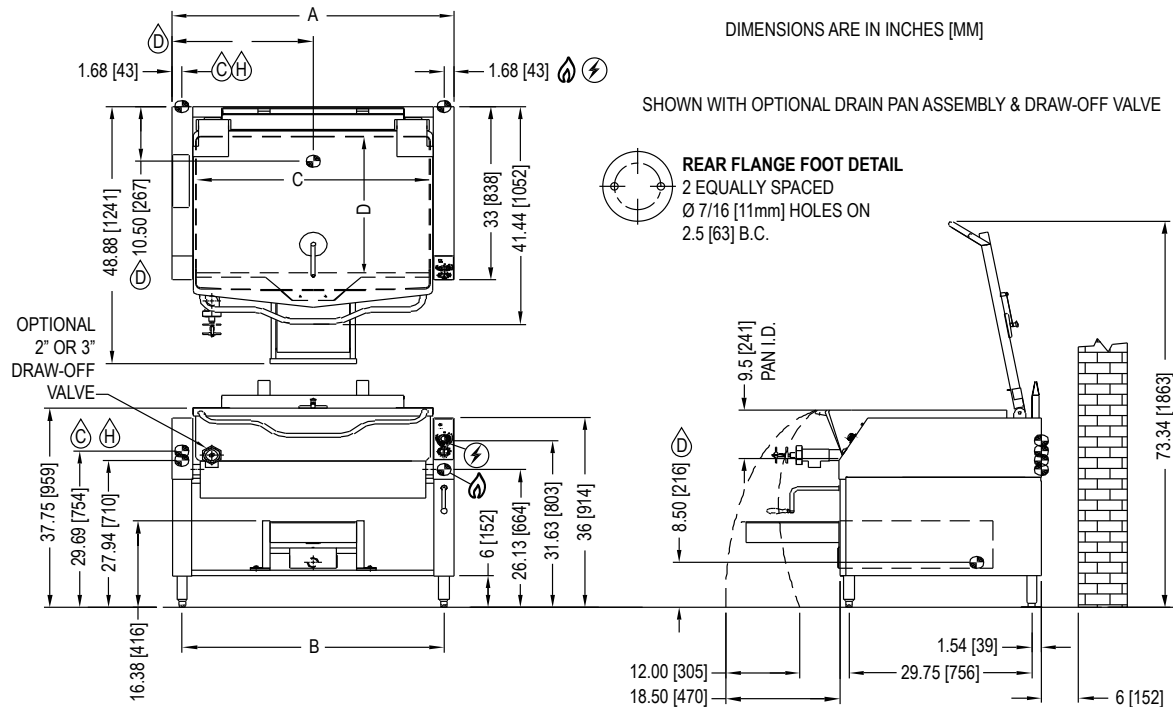

The manufacturer reserves the right to modify materials and specifications without notice.

PRINTED IN U. S. A.
SPEC SHEET: 14-0229 Rev E (12/18)

AutoQuotes

MARKET FORGE

Tel: (802) 658-6600 • Fax: (802) 864-0183 • www.marketforge.com