



GAS CABINET BASE HYDRAULIC TILTING SKILLET



SPECIFICATIONS:

Shall be a Southbend model _____, gas fired hydraulic tilting skillet, AGA/CGA and NSF certified. The unit shall have a spring assisted hinged stainless steel cover, complete with handle and a no drip condensate guide. The pan body shall have a sloped front, be front hinged for tilting and easy pour control and comes complete with removable pour lip strainer. The pan is formed from 10 gauge stainless steel with a #4 finish exterior and polished interior with coved corners for easy cleaning. The cooking surface shall be 5/8" thick stainless steel clad cooking plate for even heat distribution over entire cooking surface. The pan shall be mounted on a heavy duty welded angle constructed frame fitted with 6" (152 mm) stainless steel legs with adjustable bullet feet on the front and flanged, adjustable feet on the rear for securing to the floor. Enclosed with #4 finish type 304 stainless steel with removable side panels and two stainless steel front cabinet doors.

All controls are mounted in the cabinet base which include a solid state thermostat, temperature light, tilt switch, electronic ignition, tilt safety switch and hydraulic lift system powered by a 1/2 HP electric motor for smooth and precise tilting action. The high limit thermostat is located on the pan bottom. Cooking temperatures are between 100°F and 450°F (38°C and 232°C). Gas supply to the burners automatically shuts off when the pan is tilted.

MODEL	CAPACITY		
	BTU	GALLON	LITER
BGMTS-30	80,000	30	114
BGMTS-40	100,000	40	152

OPERATION SHALL BE BY:

- Natural Gas
- Propane Gas

Gas fired skillet operating on 115 VAC, 1 Phase, 60Hz

OPTIONAL ITEMS AT EXTRA COST:

- 220 VAC, 1 phase, 50 Hz
- Etched gallon markings (GMS-30, GMS-40)
- Etched liter markings (LMS-114, LMS-152)
- 2" draw off valve with strainer, front or side mounted (TVT-2BP)
- 3" draw off valve with strainer, side mounted (TVT-3BP)
- Correctional Package

ACCESSORIES:

- Pan carrier (PC-1)
- Pan carrier (PC-3)
- Steam pan insert (SPI-30, SPI-40)
- 12" Single pantry faucet with swing spout (SF-12)
- 12" Double pantry faucet with swing spout (DF-12)
- 3" Stainless steel faucet plumbing enclosure (3139-1)
- Single pantry faucet & bracket with 60" pot filler (SP-KF)
- Double pantry faucet & bracket with 60" pot filler (DP-KF)

Job _____
Item# _____



Models: BGMTS-30 BGMTS-40

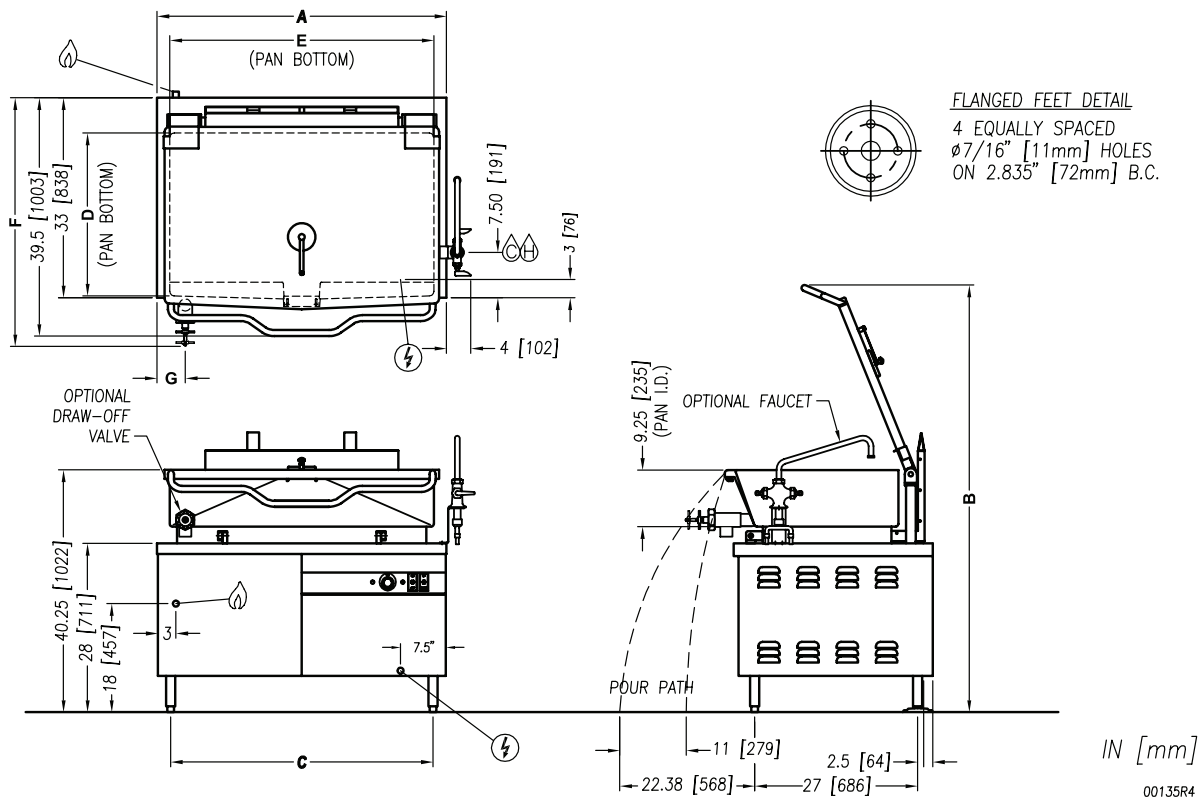

DIMENSIONS

MODEL	CAPACITY	UNITS	A	B	C	D	E	F		G
BGMTS-30	30 Gallons (114 liters)	inches (millimeters)	36" (914 mm)	70.88" (1800 mm)	30" (762 mm)	23.5" (597 mm)	33.75" (857 mm)	Ø2	Ø3	3.75" (95 mm)
								41.13" (1045 mm)	46.75" (1187 mm)	
BGMTS-40	40 Gallons (152 liters)	inches (millimeters)	48" (1219 mm)	70.88" (1800 mm)	42" (1067 mm)	23" (584 mm)	43.75" (1111 mm)	41.63" (1057 mm)	46.13" (1172 mm)	4.75" (121 mm)

MODEL	SHIPPING WEIGHT	GAS SUPPLY				MINIMUM CLEARANCE *	
		BTU/HR	KW/HR	Supply Pipe Pressure (W.C)			
BGMTS-30	650 lbs. [295 kg]	80,000	23.4	Natural 6" - 14" (152 mm - 356 mm)	Propane 11" - 14" (279 mm - 356 mm)	Sides	3" (76 mm)
BGMTS-40	825 lbs. [374 kg]	100,000	29.3			Back	6" (152 mm)

* For use on noncombustible floors only.

SERVICE CONNECTIONS

- ELECTRICAL CONNECTION: Unless otherwise specified, Field Wire Electrical Connection to be 120 Volts, 60 Hz, single phase with grounding wire. 10 Amp minimum supply.
- GAS CONNECTION: Supply gas through 3/4" pipe.
- COLD WATER: 3/8" O.D. tubing to optional faucet
- HOT WATER: 3/8" O.D. tubing to optional faucet

**INTENDED FOR COMMERCIAL USE ONLY.
NOT FOR HOUSEHOLD USE.**



1100 Old Honeycutt Road, Fuquay-Varina, NC 27526
(919) 762-1000 www.southbendnc.com