



NOR-LAKE, INCORPORATED
727 Second Street
Hudson, Wisconsin 54016

800-955-5253
715-386-2323
866-961-5253 Parts
800-388-5253 Service
715-386-6149 FAX
www.norlake.com

ADVANTEDGE™ MEGA TOP SANDWICH FOOD PREP REFRIGERATORS



PROJECT:
.....
ITEM NUMBER:
.....
MODEL NUMBER:
.....

SPECIFICATIONS FOR: NLSMP27-12A, NLSMP36-15A, NLSMP48-18A, NLSMP60-24A, NLSMP72-30A

- **Finish:** Stainless steel interior and exterior
- **Insulation:** Complete cabinet and doors are foamed-in-place with polyurethane insulation. Insulated pan cover
- **Hardware:** Curved handle with recessed pocket with one shelf per door, 6" overall height casters standard, front-breathing design allows for zero-clearance installation on sides and back.
- **Electrical:** 115 volt, 60 Hz, 1 phase with cord and plug
- **Refrigeration:** Self-contained forced air refrigeration system. The condensate is collected and automatically evaporated from an energy efficient vaporizer. Refrigerant flow is controlled by a capillary tube. R290 refrigerant. Temperature range: +34°F to +38°F for storage area, +33°F to +41°F for refrigerated pan well.
- **Accessories:** 1/6 size pans, locking pan adapter bars and 9-1/2" polyethylene cutting board included
- **Approvals:** UL, C-UL Safety and UL Sanitation listed **

STANDARD FEATURES

- 1/6 size pans included
- Locking pan adapter bars run front-to-back and side-to-side allowing mixed pan sizes
- Pan adapter bars lock together to hold pans in place
- Air cooled condensing unit
- Automatic condensate vaporizer
- Automatic defrost
- Capillary tube system
- Casters
- Cutting board
- Field reversible door on NLSMP27-12A
- Magnetic gaskets
- Self-closing doors
- Stainless steel interior and exterior
- UL, C-UL Safety & UL Sanitation listed **
- Warranties: 3 yr. parts & labor, 5 yr. compressor

OPTIONAL FEATURES*

- Additional shelves
- Overshelf assemblies (single & double)
- 6" legs in lieu of casters
- 4" casters
- Stainless steel back
- Flat lid models
- Pull out drawers

* Most options are available two weeks from receipt of order. Please contact us for specific questions.

** C-UL is Underwriters Laboratories Safety Certification Mark which indicates that UL has tested the equipment to applicable CSA Standards.

** UL Sanitation is UL Sanitation Safety Certification Mark which indicates that UL has tested the equipment to applicable NSF Standards.

MEGA TOP SANDWICH FOOD PREP REFRIGERATORS

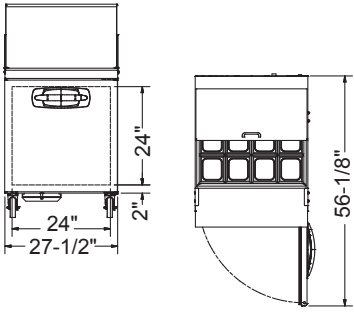

FRONT
NLSMP27-12A

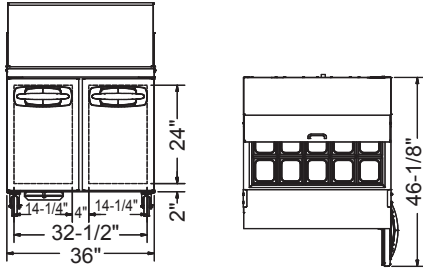

FRONT
NLSMP36-15A

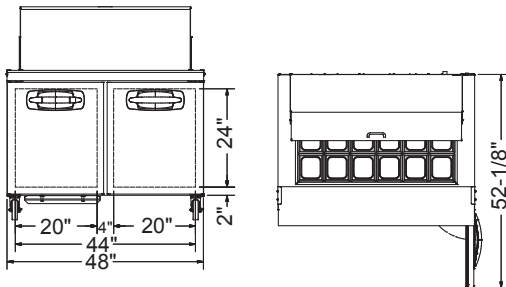

FRONT
NLSMP48-18A

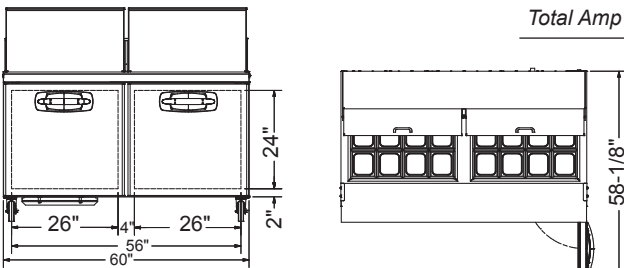

FRONT
NLSMP60-24A

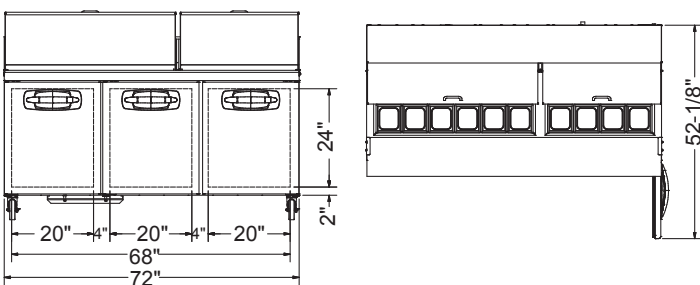

FRONT
NLSMP72-30A

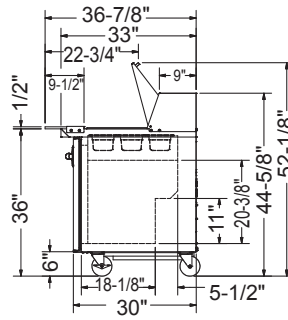

SIDE
ALL MODELS

SPECIFICATIONS

Models	NLSMP27-12A	NLSMP36-15A	NLSMP48-18A	NLSMP60-24A	NLSMP72-30A
Crated Weight (lbs) (kg)	210 (95)	266 (121)	323 (147)	378 (172)	413 (188)
Crated Height (in) (cm)	45-7/8 (117)	45-7/8 (117)	45-7/8 (117)	45-7/8 (117)	45-7/8 (117)
Crated Width (in) (cm)	30-1/8 (75)	37-1/4 (95)	51-1/8 (130)	63 (160)	74-3/8 (189)
Crated Depth (in) (cm)	38-3/4 (95)	38-3/4 (95)	38-3/4 (95)	38-3/4 (95)	38-3/4 (95)
Interior Height (in) (cm)	20-3/8 (52)	20-3/8 (52)	20-3/8 (52)	20-3/8 (52)	20-3/8 (52)
Interior Width (in) (cm)	24 (61)	32-1/2 (82)	44 (112)	56 (142)	68 (172)
Interior Depth (in) (cm)	23 (58)	23 (58)	23 (58)	23 (58)	23 (58)
Overall Height (in) (cm)	44-5/8 (113)	44-5/8 (113)	44-5/8 (113)	44-5/8 (113)	44-5/8 (113)
Overall Width (in) (cm)	27-1/2 (70)	36 (91)	48 (122)	60 (152)	72 (183)
Overall Depth* (in) (cm)	33 (84)	33 (84)	33 (84)	33 (84)	33 (84)
Gross Cubage (CuFt) (L)	7.2 (204)	9.9 (280)	13.4 (379)	16.2 (459)	20.4 (578)
Number of 1/6 Pans	12	15	18	24	30
Number of Shelves	1	2	2	2	3
Shelf Area (SqFt) (Sqm)	4.82 (0.45)	7.02 (0.65)	9.25 (0.86)	12.35 (1.15)	14.19 (1.32)
Number of Casters	4	4	4	4	4
Condensing Unit Size	1/5 HP	1/5 HP	3/8 HP	3/8 HP	3/8 HP
Refrigerant	R290	R290	R290	R290	R290
Electrical Characteristics	115/60/1	115/60/1	115/60/1	115/60/1	115/60/1
Cord and Plug Furnished	Yes	Yes	Yes	Yes	Yes
NEMA Plug Configuration	5-15P	5-15P	5-15P	5-15P	5-15P
Total Amp Draw	2.1	2.1	3.2	3.2	3.2

*Overall depth not including removable cutting board

Specifications subject to change without notice.



Revision Date: 1/19
Part Number: 143381