

Indigo™ Series 606 Ice Cube Machine

Model: ID-0606A IY-0606A ID-0606W IY-0606W ID-0696N IY-0696N



Indigo Series i-606
Ice Machine on B-570 Bin

Designed for operators who know that ice is critical to their business, the Indigo™ Series ice machine's preventative diagnostics continually monitor itself for reliable ice production. Improvements in cleanability and programmability make your ice machine easy to own and less expensive to operate.

- **New Levels of Performance** – showcasing improved ambient ice production along with reductions in energy consumption: 10% Reduction in energy and 5% improvement in production on a weighted average basis for the i-600 series.
- **ENERGY STAR** – the i-600s exceeds ENERGY STAR™ standards and targets future energy efficiency standards.
- **Space-Saving Design** – Up to 635 lbs. (288 kgs) daily ice production and only 30" (76.20 cm) wide.
- **Intelligent Diagnostics** – provide 24 hour preventative maintenance and diagnostic feedback for trouble free operation.
- **Acoustical Ice Sensing Probe** – for reliable operation in challenging water conditions.
- **EasyRead Display** – communicates operating status, cleaning reminders, and asset information through a blue illuminated display.
- **Programmable Ice Production** – by On/Off Time, Ice Volume or Bin Level (with accessory bin level control) further improves energy efficiency and savings.
- **Easy to Clean Foodzone** – Hinged front door swings out for easy access. Removable water-trough, distribution tube, curtain, and sensing probes for fast and efficient cleaning. Select components made with AlphaSan® antimicrobial.
- **DuraTech™ Exterior** – provides superior corrosion resistance. Stainless finish with innovative clear-coat resists fingerprints and dirt.
- Available **LuminIce™ Growth Inhibitor** controls the growth of bacteria and yeast within the foodzone.

Ice Machine Electric

208-230/60/1 standard.
(230/50/1 also available)

Minimum circuit ampacity:	Maximum fuse size:
Air Cooled: 11.1	Air Cooled: 15
Water Cooled: 10.7	Water Cooled: 15
Remote: 11.7	Remote: 15

Specifications

BTU Per Hour:

11,800 (average)
13,700 (peak)

Refrigerant:

R-404A CFC-free

Operating Limits:

- Ambient Temperature Range: 35° to 110°F (1.7° to 43.3°C)
Water Temperature Range: 35° to 90°F (1.7° to 32.2°C)
- Water Pressure Ice Maker Water In:
Min. 20 psi (137.9 kPa)
Max. 80 psi (551.1 kPa)



Ice Shape



Half Dice
3/8" x 1 1/8" x 7/8"
(.95 x 2.86 x 2.22 cm)



Dice
7/8" x 7/8" x 7/8"
(2.22 x 2.22 x 2.22 cm)





Indigo™ Series 606 Ice Cube Machine

i-606 on B-570 Storage Bin

- (A) Electrical Entrance (2) Options
- (B) 3/8" (0.95 cm) F.P.T. Water Condenser Inlet (water-cooled units)
- (C) 1/2" (1.27 cm) F.P.T. Water Condenser Outlet (water-cooled units)
- (D) 1/2" (1.27 cm) Auxillary Base Drain Socket
- (E) 3/8" (0.95 cm) F.P.T. Ice Making Water Inlet
- (F) 1/2" (1.27 cm) F.P.T. Ice Making Water Drain
- (G) 3/4" (1.91 cm) Bin Drain

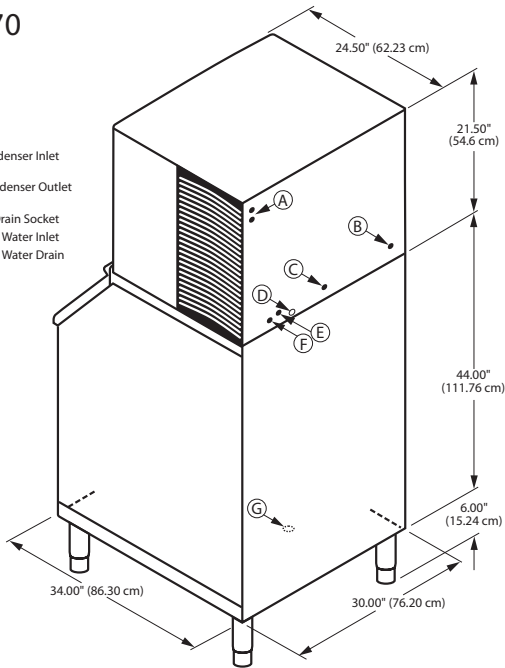

Installation Note
Minimum installation clearance:
Top/sides: 8" (20.32 cm);
Back is 5" (12.7 cm)

Space-Saving Designs



	i-606 B-400	i-606 B-570
Height	59.50" 151.13 cm	71.50" 181.61 cm
Width	30.00" 76.20 cm	30.00" 76.20 cm
Depth	34.00" 86.30 cm	34.00" 86.30 cm
Bin Storage	290 lbs. 131.7 kgs	430 lbs. 195.2 kgs

Height includes adjustable bin legs 6.00" to 8.00", (15.24 to 20.32 cm) set at 6.00" (15.24 cm).

Kit K00347 ice deflector must be ordered separately if used with: non-Manitowoc bins, Manitowoc F-Style bins and Manitowoc B-750, B-1050, B-1100, and B-1400 bins.

Specifications

	Model	Ice Shape	Ice Production 24 Hours		Power Usage kWh/100 lbs. @90°Air/70°F 1 Ph	Potable Water Usage/100 lbs. 45.4 kgs of Ice	ENERGY STAR*
			70°Air/ 50°F Water 21° Air/10°C Water	90°Air/ 70°F Water 32° Air/21°C Water			
AIR-COOLED	ID-0606A	dice	632 lbs.	490 lbs.	5.41	20.0 Gal. 75.7 L	★
			287 kgs	222 kgs			
	IY-0606A	half-dice	635 lbs.	555 lbs.	5.29	20.0 Gal. 75.7 L	★
			288 kgs	252 kgs			
WATER-COOLED	ID-0606W	dice	661 lbs.	575 lbs.	4.44	20.0 Gal. 75.7 L	NA
			300 kgs	261 kgs			
	IY-0606W	half-dice	700 lbs.	580 lbs.	4.45	20.0 Gal. 75.7 L	NA
			318 kgs	263 kgs			
* Water-cooled Condenser Water Usage / 100 lbs. /45.4 Kgs Of Ice: 140 gal./ 530 L. * Water-cooled models are excluded from ENERGY STAR qualification.							
REMOTE-COOLED	ID-0696N	dice	612 lbs.	535 lbs.	5.85	20.0 Gal. 75.70 L	★
			278 kgs	243 kgs			
	IY-0696N	half-dice	642 lbs.	565 lbs.	5.76	20.0 Gal. 75.7 L	★
			291 kgs	256 kgs			

Order ice storage bin separately. Ice storage bin and JC-0895 remote condenser must be ordered separately. Consult remote condenser specification sheet for details.

Accessories

LuminIce™ Growth Inhibitor reduces yeast and bacteria growth for a cleaner ice machine.



Bin Level Control Allows ice bin level to be automatically set. Built-in LED light illuminates bin.



Arctic Pure® Water Filters Reduces sediment and chlorine odors for better tasting ice.



iAuCS® schedules and performs routine ice machine cleaning automatically.





Ice Storage Bins

Model

- D320
 D400
 D420
 D570
 D970

D Bins

.75" (1.90 cm) Bin drain

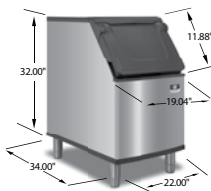

D320
210 lbs. (95 kgs)
(Available January)

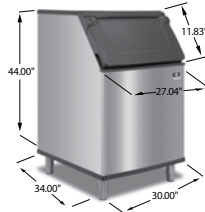

D570
430 lbs. (195 kgs)
(Available January)



D400
290 lbs. (132 kgs)
(Available January)



D420
310 lbs. (141 kgs)
(Available January)



D970
710 lbs. (323 kgs)



Ergonomic NSF approved sanitary ice scoop included

D Bin Features

New Sanitary Scoop Ergonomic NSF approved sanitary ice scoop included with each bin. Built-in knuckle and thumb guard. Unique molded retaining lip allows maximum scooping every time. Per scoop capacity approximately 5.3/ lbs (2.4 kg)

Scoop Holder options New built-in scoop holder, keeps the ice scoop handle above the ice, or purchases the optional NSF approved External Scoop Holder Kit # K00461. (Available January 2018)

New Door design Clever built in side grips allow you to lift the bin door from anywhere you are standing (left, right or center) even when you have just one hand free.

Foamed Insulated Door

Insulates the ice bin, reduces sweat on the door, helps keep ice lasting longer.

Stay up door Unique cammed bin door self-latch keeps the door in the open position and keeps the employee safe when scooping ice.

Ergonomic Door design Door is angled 53 degrees to allow for easier access to the ice in the bin especially when scooping from the bottom.

Duratech Metal Finish Manitowoc exterior material has better corrosion resistance than stainless steel, is smudge resistant and easy to keep clean.

New Bin liner Polyurethane Artic Blue bin liner accentuates the crisp clear ice from a Manitowoc Ice Machine.

Warranty

Bin & Accessories: 3 Year Parts & Labor.

D Bin Model	D-Bin Capacities						D-Bin Dimensions					
	*Application Capacity		**2017 AHRI Capacity		**2018 AHRI Capacity		Height		Width		Depth	
	lbs.	kgs	lbs.	kgs.	Cu. ft	Cu. M	in.	cm	in.	cm	in.	cm
D320	264	119.90	210	95.25	8.9	0.25	38	96.5	22	55.9	34	86.4
D420	383	173.79	310	140.61	12.9	0.37	50	127	22	55.9	34	86.4
D400	365	165.70	290	131.54	12.3	0.35	38	96.5	30	76.2	34	86.4
D570	532	241.14	430	195.05	17.9	0.51	50	127	30	76.2	34	86.4
D970	882	400.11	710	322.05	29.7	0.84	50	127	48	121.9	34	86.4

*Application Capacity is based on 90% of the volume x 33 lbs/ft³ average density of ice. Ice must be managed
 **2017 Approved AHRI capacity is based on 80% of the total volume x 30 lbs/ft³ average density of ice
 ***2018 AHRI certified measurement for bin capacity

Above bin heights include leg height of 6" / 15.24 cm
 All bins include sanitary plastic ice scoop and one set of adjustable (6 in to 7.75 in / 15.24 to 20.32 cm) chrome legs
 External Scoop holder order separately Kit # 000461



Welbilt reserves the right to make changes to the design or specifications without prior notice.



Ice Storage Bins

D Bins

Indigo Ice Machines Series												
Machine			iT420	iT620	i300	iT450	iT500	i606, i686C	i906, i976C	iT1200, iT1200C	i1470C, i1870C, i2170C	iT1500, iT1900
Machine Capacity @90/70 F			375	465	235	378	440	555, 530	710, 710	950, 1000	1200, 1470, 1691	1360, 1455
Bins	Bin Cap	Width	22"	22"	30"	30"	30"	30"	30"	30"	30"	48"
D320	210	22"	*	*								
D420	290	22"	*	*								
D400	310	30"	K-00443	K-00443	*	*	*	*	NR	NR	NR	
D570	430	30"	K-00443	K-00443	*	*	*	*	*	*	NR	
D970	710	48"	NR	NR	NR	K-00458	K-00458	K-00458	K-00458	K-00458	K-00385	*

Manitowoc Flaker and Nugget Machines											
Machine			RNS0308 & RNF320	RFS0300 &RFF320	RNF620	RFF0620	RNF1020	RFF1220	RNF1100	RFF1300	RFF2200C
Machine cap			251	286	451	540	825	958	825	874	1702
Bins	Bin cap	Width	22"	22"	22"	22"	22"	22"	30"	30"	36.7"
D320	210	22"	*	*	NR	NR	NR	NR			
D420	310	22"	*	*	*	*	NR	NR			
D400	290	30"	K-00443	K-00443	K-00443	K-00443	NR	NR	NR	NR	
D570	430	30"	NR	K-00443	K-00443	K-00443	NR	NR	*	*	
D970	710	48"	NR	NR	K-00444	K-00444	K-00371 if 2 used.	K-00371 if 2 used.	K-00458	K-00458	K-00458

An optional adapter is required when putting a narrower ice machine on a wider bin.
 * No adapter is needed
 NR= Not Recommend. Bin too small or too large for application.
 Putting a wider machine on narrower bin is not an option.
 Machines side by side must be water cooled or remote.
 Bin Capacity shown in lbs using the AHRI rating base on 80% of total volume x 30lb/ft³ average density of ice.
 Machine capacity shown in lbs/24hrs using the AHRI rating base at 90F ambient, 70F water temperature

Available Accessories See price book for replacement: scoops, legs, specialty legs and casters

K00146 Convenient Ice Bagger

Includes bagger, D-bin adapter, and 250 bags and ties (Not for D320 or D400) Order K00068 replacement bags



K00461 External Scoop Holder

NSF approved. Can be mounted on the left or right side of bins, horizontally or vertically or on a wall.



000013960 Metal Scoop

Indestructible aluminum alloy with sanitary knuckle and thumb guard. Works with K00461 external scoop holder or hangs inside the D-Bin series



K00462 Secure Fastening Kit

Securely fast the Indigo[®] ice machine head to the pre-drilled inserts on the back of the D-bin series. Stainless steel flanged feet attach to bin and can be screwed to the floor

