

iT1900 Ice Cube Machine

Models

- IRT1900A IDT-1900A IYT1900A IDT1900W
- IYT1900W IRT1900N IDT1900N IYT1900N



Indigo NXT Series iT1900 Ice Machine on D970 Bin

Designed for operators who know that ice is critical to their business, the Indigo NXT Series ice machine's preventative diagnostics continually monitor itself for reliable ice production. Improvements in cleanability and programmability make your ice machine easy to own and less expensive to operate.

- **New levels of Performance** – Showcasing an average of 14% lower energy consumption, 10% reduction in in potable water usage and a 23% reduction in condenser water usage. This translates into lower cost of ownership over the life of your machine.
- **easyTouch® Display** - New icon based touch screen takes the guess work out of owning and operating an ice machine.
- **Programmable Ice Production** – Now its super easy to program your ice machine to be off at certain times of the day to save money with fluctuating electrical rates. Also programmable by daily ice production volume.
- **Easy to Clean Foodzone** – Easy Access front door panel. Removable water-trough, distribution tube, curtain, and sensing probes for fast and efficient cleaning. Select components made with AlphaSan® antimicrobial.
- **Intelligent Diagnostics** – Provides 24 hour preventative maintenance and diagnostic feedback for trouble free operation.
- **Acoustical Ice Sensing Probe** – Unique patented technology allows for reliable operation in challenging water conditions and environments
- **DuraTech® Exterior** – Provides superior corrosion resistant above stainless steel. Innovative clear-coat resists fingerprints and dirt making it easier to keep clean.
- Available **LuminIce® II Growth Inhibitor** – Controls the growth of bacteria and yeast within the Food zone keeping the machine cleaner longer. A new indicator in the display keeps you abreast of the operational status.

Ice Machine Electric

208-230/60/1 standard

Minimum circuit ampacity:

| | | |
|----------------|----------|----------|
| Air-cooled: | 17.9 1ph | 14.2 3ph |
| Water-cooled: | 15.0 1ph | 12.8 3ph |
| Remote-cooled: | 18.5 1ph | 13.0 3ph |

Maximum fuse size:

| | | |
|----------------|--------|--------|
| Air-cooled: | 30 1ph | 20 3ph |
| Water-cooled: | 25 1ph | 20 3ph |
| Remote-cooled: | 30 1ph | 20 3ph |



Specifications

Operating Limits:

BTU Per Hour:
26,100 (average),
and 30,500 (peak)

- Ambient Temperature Range: 40° to 110°F (4.4° to 43.3° C)
- Water Temperature Range: 40° to 90°F (4.4° to 32.2° C)

Refrigerant:
R-410 CFC-free

- Water Pressure Ice Maker Water In:
Min. 20 psi (137.9 kPa)
Max. 80 psi (551.1 kPa)

Ice Shape

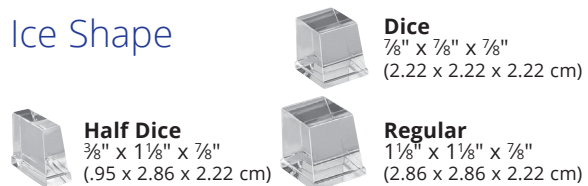

COMPANY WITH QUALITY SYSTEM



iT1900 on D970 Storage Bin

- Ⓐ Electrical Entrance (2) Options
- Ⓑ 1/2" (1.27 cm) F.P.T. Water Condenser Outlet (water-cooled units)
- Ⓒ 3/8" (0.95 cm) F.P.T. Water Condenser Inlet (water-cooled units)
- Ⓓ 3/8" (0.95 cm) F.P.T. Ice Making Water Inlet
- Ⓔ 1/2" (1.27 cm) F.P.T. Ice Making Water Drain
- Ⓕ 1/2" (1.27 cm) Auxillary Base Drain Socket
- Ⓖ 3/4" (1.91 cm) Bin Drain

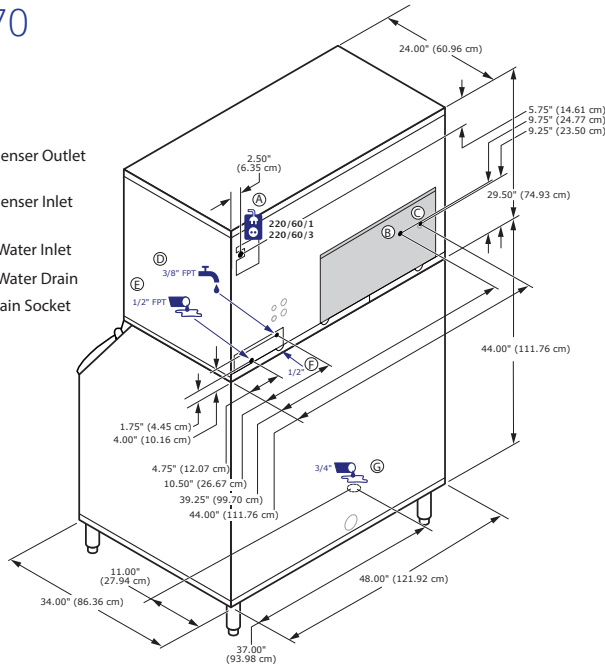

Installation Note

Air Cooled clearance:

- Top: 12" (30.5 cm)
- Sides: 8" (20.3 cm)
- Back: 5" (12.5 cm)

Water Cooled clearance:

- Top/Sides: 8" (20.3 cm)
- Back: 5" (12.7 cm)

Space-Saving Design



| | iT1900 D970 |
|-------------|------------------|
| Height | 79.50" 201.90 cm |
| Width | 48.00" 121.92 cm |
| Depth | 34.00" 86.30 cm |
| Bin Storage | 710lbs 322.2 kgs |

Height includes adjustable bin legs 6.00" to 8.00", (15.24 to 20.32 cm) set at 6.00" (15.24 cm).

Specifications

| | Model | Ice Shape | Ice Production 24 Hours | | Power Usage kWh/100 lbs. @90°Air/70°F | Potable Water Usage/100 lbs. 45.4 kgs. of Ice |
|---------------|----------|-----------|-------------------------|--------------------|---------------------------------------|---|
| | | | 70°Air/ 50°F Water | 90°Air/ 70°F Water | | |
| AIR-COOLED | IRT1900A | regular | 1,800 lbs. | 1,350 lbs. | 4.68 | 20 Gal. |
| | | | 816 kgs | 612 kgs | | 75.7 L |
| | IDT1900A | dice | 1,900 lbs. | 1,410 lbs. | 4.64 | 20 Gal. |
| WATER-COOLED | IYT1900A | half-dice | 1,900 lbs. | 1,450 lbs. | 4.48 | 20 Gal. |
| | | | 845 kgs | 661 kgs | | 75.7 L |
| | IDT1900W | dice | 1,770 lbs. | 1,575 lbs. | 3.77 | 20 Gal. |
| REMOTE-COOLED | IYT1900W | half-dice | 1,740 lbs. | 1,575 lbs. | 3.80 | 20 Gal. |
| | | | 789 kgs | 714 kgs | | 75.7 L |
| | IRT1900N | regular | 1,715 lbs. | 1,424 lbs. | 4.59 | 20 Gal. |
| REMOTE-COOLED | IDT1900N | dice | 823 kgs | 702 kgs | 4.51 | 75.7 L |
| | | | 1,815 lbs. | 1,547 lbs. | | 20 Gal. |
| | IYT1900N | half-dice | 1,800 lbs. | 1,550 lbs. | 4.53 | 20 Gal. |
| | | | 816 kgs. | 703 kgs | | 75.7 L |

* Water-cooled Condenser Water Usage / 100 lbs. /45.4 kgs. Of Ice: 145 gal./ 549 L.
 * Water-cooled models are excluded from ENERGY STAR qualification.

Order separately: Ice storage bin for all units, line-set and remote condenser unit JCT1500 for remote cooled units. When ordering single phase water and remote units, add "A" after the 261. Example IDT 1900N-261A

Accessories

LuminIce[®] II Growth Inhibitor reduces yeast and bacteria growth for a cleaner ice machine.



External Scoop holder Protect the ice scoop with the NSF approved versatile scoop holder.

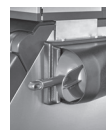

Arctic Pure[®] Water Filters Reduces sediment and chlorine odors for better tasting ice.



iAUCS[®] schedules and performs routine ice machine cleaning automatically.

