

300 Ice Cube Machine

300 Ice Cube Machine

Models ID-0302A IY-0304A ID-0303W IY-0305W



Indigo Series i-300
Ice Machine on D-400 Bin

Designed for operators who know that ice is critical to their business, the Indigo® Series ice machine's preventative diagnostics continually monitor itself for reliable ice production. Improvements in cleanability and programmability make your ice machine easy to own and less expensive to operate.

- **Space-Saving Design** – Measures only 16.5" high (42 cm) and 30" wide (76.20 cm) allowing it to fit on top of dispensers when a low ceiling is an issue.
- **Intelligent Diagnostics** – provide 24 hour preventative maintenance and diagnostic feedback for trouble free operation.
- **Acoustical Ice Sensing Probe** – for reliable operation in challenging water conditions.
- **EasyRead® Display** – communicates operating status, cleaning reminders, and asset information through a blue illuminated display.
- **Programmable Ice Production** – by On/Off Time, Ice Volume or Bin Level (with accessory bin level control) further improves energy efficiency and savings.
- **Easy to Clean Foodzone** – Hinged front door swings out for easy access. Removable water-trough, distribution tube, curtain, and sensing probes for fast and efficient cleaning. Select components made with AlphaSan® antimicrobial.
- **DuraTech™ Exterior** – provides superior corrosion resistance. Stainless finish with innovative clear-coat resists fingerprints and dirt.
- Available LuminIce® Growth Inhibitor mitigates the growth of bacteria and yeast within the foodzone.

Ice Machine Electric

115/60/1 standard.
(208-230/60/1 and 230/50/1 also available.)

Minimum circuit ampacity:

Air-cooled: 10.8
Water-cooled: 10

Maximum fuse size:

15 amps 1ph

Specifications

BTU Per Hour:

4,600 (average), 5,450 (peak)

Refrigerant:

R-404A CFC-free

Operating Limits:

- Ambient Temperature Range: 35° to 110°F (1.7° to 43.3°C)
- Water Temperature Range: 35° to 90°F (1.7° to 32.2°C)
- Water Pressure Ice Maker Water In: Min. 20 psi (137.9 kPa) Max. 80 psi (551.1 kPa)



Ice Shape



Half Dice
3/8" x 1 1/8" x 7/8"
(.95 x 2.86 x 2.22 cm)



Dice
7/8" x 7/8" x 7/8"
(2.22 x 2.22 x 2.22 cm)



COMPANY WITH
QUALITY SYSTEM
CERTIFIED BY DNV
= ISO 9001:2008 =



i-300 Storage Bin

Installation Note
 Water Cooled clearance:
 Top/Sides: 8" (20.3 cm)
 Back: 5" (12.7 cm)

Air Cooled clearance:
 Top/Sides: 16" (40.6 cm)
 Back: 5" (12.7 cm)

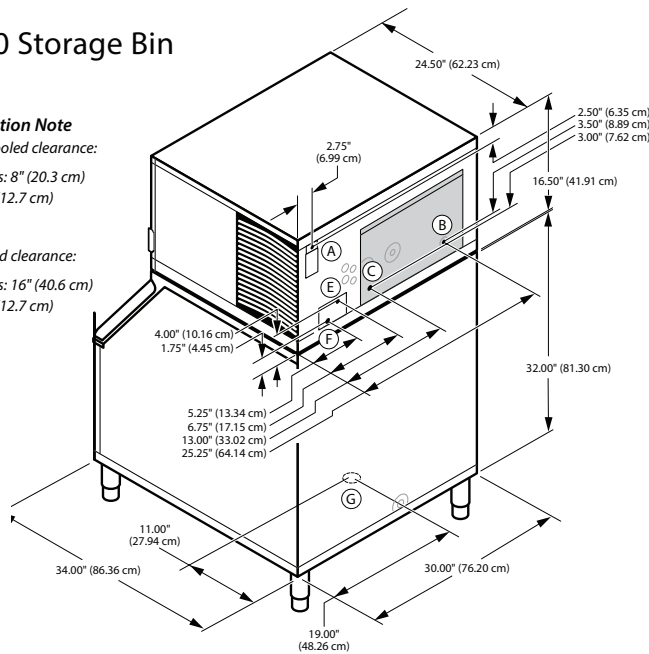

- (A) Electrical Entrance (2) Options
- (B) 3/8" (0.95 cm) F.P.T. Water Condenser Inlet (water-cooled units)
- (C) 1/2" (1.27 cm) F.P.T. Water Condenser Outlet (water-cooled units)
- (D) 1/2" (1.27 cm) Auxillary Base Drain Socket
- (E) 3/8" (0.95 cm) F.P.T. Ice Making Water Inlet
- (F) 1/2" (1.27 cm) F.P.T. Ice Making Water Drain
- (G) 3/4" (1.91 cm) Bin Drain

Space-Saving Designs



i-300 B-400
 Height 54.50" / 138.43 cm
 Width 30.00" / 76.20 cm
 Depth 34.00" / 86.30 cm
 Bin Storage 290 lbs. / 131.50 kgs.

Height includes adjustable bin legs 6.00" to 8.00" (15.24 to 20.32 cm) set at 6.00" (15.24 cm).

Specifications

| | Model | Ice Shape | Ice Production 24 Hours | | Power Usage kWh/100 lbs. @90°Air/70°F | Water Usage/ 100 lbs. 45.4 kgs. of Ice |
|---------------------|----------|-----------|-------------------------|--------------------|---------------------------------------|--|
| | | | 70°Air/ 50°F Water | 90°Air/ 70°F Water | | |
| AIR-COOLED | ID-0302A | dice | 310 lbs. | 225 lbs. | 7.00 | 20.0 gal |
| | | | 141 kgs. | 102 kgs. | | 75.7 L |
| | IY-0304A | half-dice | 310 lbs. | 235 lbs. | 7.00 | 20.0 gal |
| | | | 141 kgs. | 107 kgs. | | 75.7 L |
| WATER-COOLED | ID-0303W | dice | 300 lbs. | 260 lbs. | 5.45 | 20.0 gal |
| | | | 136 kgs. | 118 kgs. | | 75.7 L |
| | IY-0305W | half-dice | 300 lbs. | 260 lbs. | 5.45 | 20.0 gal |
| | | | 136 kgs. | 118 kgs. | | 75.7 L |

* Water-cooled Condenser Water Usage / 100 lbs. /45.4 kgs. Of Ice: 194 gal / 734 L .
 * Water-cooled models are excluded from ENERGY STAR qualification.

Order ice storage bin separately.

Accessories

LuminIce® II Growth Inhibitor
 reduces yeast and bacteria growth for a cleaner ice machine.

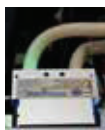

External Scoop holder
 Protect the ice scoop with the NSF approved versatile scoop holder.

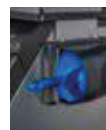

Arctic Pure® Water Filters
 Reduces sediment and chlorine odors for better tasting ice.



iAuCS®
 schedules and performs routine ice machine cleaning automatically.



Welbilt reserves the right to make changes to the design or specifications without prior notice.



SPA-310 • SFA-291 Ice Dispensers

Model

SPA-310

SFA-291

SPA Model

Designed for ice bucket filling in hotels, motels, and resorts

With Indigo and Indigo NXT ice machines you can program the ice machines to be off certain hours of the day so that while the hotel guests are sleeping, the ice machine can be too!



Indigo NXT iT0450 Ice Machine
SPA-310 Ice Dispenser

SFA Model

Designed for "large" container ice filling.

Built-in water valve



Indigo NXT iT0450 Ice Machine
SFA-291 Ice & Water Dispenser



Standard Features

- 180 lbs. (82 kgs.) ice storage capacity. Accepts 22" (55.88 cm) or 30" (76.2 cm) wide Manitowoc ice machine.
- Only 30" (76.2 cm) wide, 32" (81.28 cm) deep, and 82" high (208.28 cm).
- Patented rocking chute dispense mechanism reduces in-flight ice and ice spillage with quick on/off activation.
- Efficient built-in agitator assures 100% dispensing. Oversized drain pan collects larger quantity of ice overflow.
- DuraTech™ exterior provides superior corrosion resistance. Stainless finish with innovative clear-coat resists fingerprints and dirt.

Warranty

- 5-year parts and 5-year labor coverage on ice machine evaporator.
- 5-year parts and 3-year labor coverage on ice machine compressor.
- 3-year parts-and-labor coverage on all other ice machine and dispenser components.

Ice Shape



Half Dice
3/8" x 1 1/8" x 7/8"
(.95 x 2.86 x 2.22 cm)



Dice
7/8" x 7/8" x 7/8"
(2.22 x 2.22 x 2.22 cm)



COMPANY WITH
QUALITY SYSTEM
CERTIFIED BY DNV
= ISO 9001:2008 =

Welbilt reserves the right to make changes to the design or specifications without prior notice.

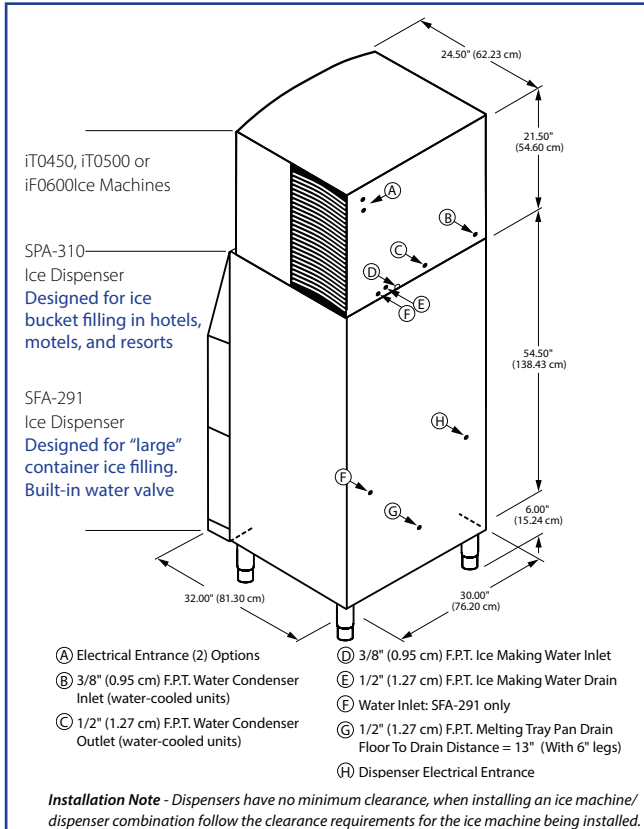

Ice Machine Electric

Note: Dispenser will accept single 22" or 30" wide ice machine.* Ice machine ordered separately. Choose Dice or Half Dice cube size. Refer to ice machine specification sheet for electrical and complete AHRI standard ratings.

Dispenser Electric:

115/60/1. (208-230/60/1 and 230/50/1 also available.)

Maximum Circuit Fuse Size:

15.0 amps. HACR-type circuit breakers can be used in place of fuses.

Dispenser Electrical Connection:

6' power cord, rated 125 VAC, 16-3 conductors with standard 3-prong, straight-blade, ground-type plug (NEMA configuration 5-15P).

Motor:

1.6 amps maximum. Permanently lubricated.

Service Access:

Dispenser door removes easily to access components.

Model Options:

SPA-310 push-for-ice rocking chute, SFA-291 has a water valve option.

*22" wide ice machines on 30" wide dispensers require K-00365 Adapter & K-00348 Baffle.

Series iF0300 (115 volt)--Available June 2018

| Model | Ice Shape | Ice Production 24 Hours | | | |
|----------|-----------|-------------------------|------|-------------------|------|
| | | 70°Air/50°F Water | | 90°Air/70°F Water | |
| | | lbs. | kgs. | lbs. | kgs. |
| IDF0300A | dice | 310 | 141 | 225 | 102 |
| IDF0300W | dice | 300 | 136 | 260 | 118 |
| IYF0300A | half-dice | 310 | 141 | 235 | 107 |
| IYF0300W | half-dice | 300 | 136 | 260 | 118 |

Series iT0500 (115 volt)

| Model | Ice Shape | Ice Production 24 Hours | | | |
|----------|-----------|-------------------------|------|-------------------|------|
| | | 70°Air/50°F Water | | 90°Air/70°F Water | |
| | | lbs. | kgs. | lbs. | kgs. |
| IDT0500A | dice | 520 | 236 | 400 | 181 |
| IDT0500W | dice | 500 | 227 | 400 | 181 |
| IYT0500A | half-dice | 550 | 249 | 440 | 200 |
| IYT0500W | half-dice | 535 | 243 | 460 | 209 |

Series iT0500 (115 volt)

| Model | Ice Shape | Ice Production 24 Hours | | | |
|----------|-----------|-------------------------|------|-------------------|------|
| | | 70°Air/50°F Water | | 90°Air/70°F Water | |
| | | lbs. | kgs. | lbs. | kgs. |
| IDT0450A | dice | 470 | 213 | 358 | 162 |
| IDT0450W | dice | 430 | 195 | 360 | 163 |
| IYT0450A | half-dice | 490 | 222 | 378 | 171 |
| IYT0450W | half-dice | 470 | 213 | 420 | 191 |

Series iF0600 (208-230 volt) -- Available June 2018

| Model | Ice Shape | Ice Production 24 Hours | | | |
|----------|-----------|-------------------------|------|-------------------|------|
| | | 70°Air/50°F Water | | 90°Air/70°F Water | |
| | | lbs. | kgs. | lbs. | kgs. |
| IDF0600A | dice | 632 | 287 | 490 | 222 |
| IDF0600W | dice | 661 | 300 | 575 | 261 |
| IYF0600A | half-dice | 635 | 288 | 555 | 252 |
| IYF0600W | half-dice | 700 | 318 | 580 | 263 |

Lumince® II Growth Inhibitor reduces yeast and bacteria growth for a cleaner ice machine.



ArcticPure® Water Filters

AR-Pre filters, dirt, rust and sediment.



AR-10000 reduces: scale, chlorine taste, and odor. Ice looks and tastes better.

