

# Indigo™ Series 906 Ice Cube Machine

Model:  IR-0906A  ID-0906A  IY-0906A  IR-0906W  ID-0906W  IY-0906W  
 IR-0996N  ID-0996N  IY-0996N



Indigo Series i-906  
Ice Machine on B-570 Bin

Designed for operators who know that ice is critical to their business, the Indigo™ Series ice machine's preventative diagnostics continually monitor itself for reliable ice production. Improvements in cleanability and programmability make your ice machine easy to own and less expensive to operate. New Levels of Performance—showcasing improved ice harvest along with reductions in energy consumption.

- **ENERGY STAR** – the i-906 exceeds ENERGY STAR standards and targets future energy efficiency standards.
- **Space-Saving Design** – Up to 901 lbs. (409 kg) daily ice production and only 30" (76.20 cm) wide.
- **Intelligent Diagnostics** – provide 24 hour preventative maintenance and diagnostic feedback for trouble free operation.
- **Acoustical Ice Sensing Probe** – for reliable operation in challenging water conditions.
- **EasyRead Display** – communicates operating status, cleaning reminders, and asset information through a blue illuminated display.
- **Programmable Ice Production** – by On/Off Time, Ice Volume or Bin Level (with accessory bin level control) further improves energy efficiency and savings.
- **Easy to Clean Foodzone** – Hinged front door swings out for easy access. Removable water-trough, distribution tube, curtain, and sensing probes for fast and efficient cleaning. Select components made with AlphaSan® antimicrobial.
- **DuraTech™ Exterior** – provides superior corrosion resistance. Stainless finish with innovative clear-coat resists fingerprints and dirt.
- Available **LuminIce™ Growth Inhibitor** controls the growth of bacteria and yeast within the foodzone.

## Specifications

### BTU Per Hour:

12,700 (average)  
14,800 (peak)

### Refrigerant:

R-404A CFC-free

### Operating Limits:

Ambient Temperature Range:  
35° to 110°F (1.7° to 43.3°C)  
Water Temperature Range:  
35° to 90°F (1.7° to 32.2°C)  
Water Pressure Ice Maker Water In:  
Min. 20 psi (137.9 kPa)  
Max. 80 psi (551.1 kPa)

## Ice Machine Electric

208-230/60/1  
(208-230/60/3 and 230/50/1 also available)

### Minimum circuit ampacity:

Air-cooled: 12.2 1ph 9.7 3ph  
Water-cooled: 11.2 1ph 8.7 3ph  
Remote: 12.2 1ph 9.7 3ph

### Maximum fuse size:

Air-cooled: 20 1ph 15 3ph  
Water-cooled: 20 1ph 15 3ph  
Remote: 20 1ph 15 3ph

## Ice Shape

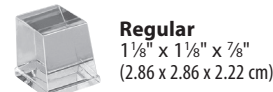
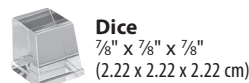
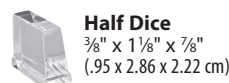

COMPANY WITH  
QUALITY SYSTEM  
CERTIFIED BY DNV  
= ISO 9001:2008 =



# Indigo™ Series 906 Ice Cube Machine

## i-906 on B-570 Storage Bin

- (A) Electrical Entrance (2) Options
- (B) 3/8" (0.95 cm) F.P.T. Water Condenser Inlet (water-cooled units)
- (C) 1/2" (1.27 cm) F.P.T. Water Condenser Outlet (water-cooled units)
- (D) 1/2" (1.27 cm) Auxillary Base Drain Socket
- (E) 3/8" (0.95 cm) F.P.T. Ice Making Water Inlet
- (F) 1/2" (1.27 cm) F.P.T. Ice Making Water Drain
- (G) 3/4" (1.91 cm) Bin Drain

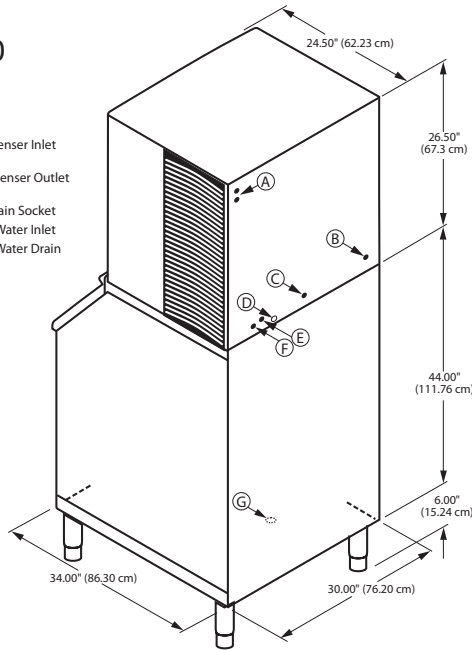

**Installation Note**  
 Minimum installation clearance:  
 Top/sides: 8" (20.32 cm);  
 Back is 5" (12.7 cm)

## Space-Saving Designs



|             | <b>i-906 B-570</b>   | <b>i-906 B-970*</b>    |
|-------------|----------------------|------------------------|
| Height      | 76.50"<br>194.30 cm  | 76.50"<br>194.30 cm    |
| Width       | 30.00"<br>76.20 cm   | 48.00"<br>121.92 cm    |
| Depth       | 34.00"<br>86.30 cm   | 34.00"<br>86.30 cm     |
| Bin Storage | 430 lbs.<br>195 kgs. | 710 lbs.<br>322.2 kgs. |

Height includes adjustable bin legs 6.00" to 8.00", (15.24 to 20.32 cm) set at 6.00" (15.24 cm).

\*For comparison purposes multiply ARI capacity by 1.3 (30%) to arrive at approximate "Application Rating Capacity."

## Specifications

|   | Model    | Ice Shape | Ice Production 24 Hours |                    |         |        | Power Usage kWh/100 lbs.@90°Air/70°F |      | Water Usage/100 lbs. 45.4 kgs. of Ice |        | ENERGY STAR® |
|---|----------|-----------|-------------------------|--------------------|---------|--------|--------------------------------------|------|---------------------------------------|--------|--------------|
|   |          |           | 70°Air/ 50°F Water      | 90°Air/ 70°F Water | 1 Ph    | 3 Ph   | Potable Water                        |      |                                       |        |              |
| <b>AIR-COOLED</b>   | IR-0906A | regular   | 797 lbs                 | 362 kg             | 639 lbs | 290 kg | 5.33                                 | 5.33 | 19 Gal.                               | 71.9 L | ★            |
|   | ID-0906A | dice      | 874 lbs                 | 396 kg             | 664 lbs | 301 kg | 5.10                                 | 5.10 | 19 Gal.                               | 71.9 L | ★            |
|   | IY-0906A | half-dice | 901 lbs                 | 409 kg             | 710 lbs | 322 kg | 5.02                                 | 5.02 | 19 Gal.                               | 71.9 L | ★            |
| <b>WATER-COOLED</b>   | IR-0906W | regular   | 773 lbs                 | 351 kg             | 683 lbs | 310 kg | 4.20                                 | 4.20 | 19 Gal.                               | 71.9 L | NA           |
|   | ID-0906W | dice      | 839 lbs                 | 381 kg             | 701 lbs | 318 kg | 4.35                                 | 4.35 | 19 Gal.                               | 71.9 L | NA           |
|   | IY-0906W | half-dice | 879 lbs                 | 399 kg             | 786 lbs | 357 kg | 4.04                                 | 4.04 | 19 Gal.                               | 71.9 L | NA           |
| * Water-cooled Condenser Water Usage / 100 lbs. /45.4 kgs. Of Ice: 150 gal/568 L.<br>* Water-cooled models are excluded from ENERGY STAR qualification. |          |           |                         |                    |         |        |                                      |      |                                       |        |              |
| <b>REMOTE-COOLED</b>  | IR-0996N | regular   | 753 lbs                 | 342 kg             | 665 lbs | 302 kg | 5.29                                 | 5.29 | 19 Gal.                               | 71.9 L | ★            |
|   | ID-0996N | dice      | 821 lbs                 | 372 kg             | 727 lbs | 330 kg | 4.91                                 | 4.91 | 19 Gal.                               | 71.9 L | ★            |
|   | IY-0996N | half-dice | 855 lbs                 | 388 kg             | 752 lbs | 341 kg | 4.90                                 | 4.90 | 19 Gal.                               | 71.9 L | ★            |

Order ice storage bin separately. Ice storage bin and JC-0995 remote condenser must be ordered separately. Consult remote condenser specification sheet for details. To order 3 phase add "3" suffix to model # (ID-0906A3).

## Accessories

**LuminIce™ Growth Inhibitor** reduces yeast and bacteria growth for a cleaner ice machine.



**Bin Level Control** Allows ice bin level to be automatically set. Built-in LED light illuminates bin.



**Arctic Pure® Water Filters** Reduces sediment and chlorine odors for better tasting ice.



**AuCS®** schedules and performs routine ice machine cleaning automatically.

